

MP100

User's Guide



Rev.F
Sep 2018

MP100 User's Guide

Contents

Read Before Operating	2
General Information	3
User Interface	3
Display	4
Using MP100.....	5
Turn the unit on.....	5
Warm up sequence	5
Normal mode	6
Real time reading	6
STEL screen.....	6
TWA screen	6
Peak screen	6
Min screen (for Oxygen sensor only).....	7
Turn the unit off	7
Config mode.....	7
Enter Config mode	7
Sensor calibration.....	8
Calibration adapter.....	8
Zero calibration	9
Span calibration	9
Bump test	10
Change alarm limit	10
Change bump/cal interval	11
Change span value	12
Change display unit	12
Vibrator enable/disable.....	12
Power on zero enable/disable	13
Fast power on enable/disable	13
Reset config.....	13
Exit Config mode.....	14
Maintenance	14
Replace the battery	14
Replace the sensor filter.....	15
Replace the sensor	15
Ordering information	17
Specifications	18
Sensor configuration	19
Alarm signal summary	20
Trouble shooting.....	22

MP100 User's Guide

Read Before Operating

This manual must be carefully read by all individuals who have or will have the responsibility of using, maintaining or servicing this product. The product will perform as designed only if it is used, maintained and serviced in accordance with the manufacturer's instructions.

Warning

- Never operate the monitor when the cover is removed.
- Remove the monitor cover and battery only in area known as non-hazardous.
- Use only mPower's lithium battery part number 1.17.02.0002 (3.6V, 2700mAh, AA size) or part No. ER14505 cell manufactured by EVE Energy Co., LTD
- This instrument has not been tested in an explosive gas/air atmosphere having an oxygen concentration greater than 21%.
- Substitution of components will impair suitability for intrinsic safety.
- Substitution of components will void warranty.
- It is recommended to bump test with a known concentration gas to confirm the instrument is functioning properly before use.
- Before use, ensure that the ESD film on the display is not damaged or peeling.

Avertissement:

- N'utilisez jamais le moniteur lorsque le couvercle est enlevé.
- Retirer le couvercle du moniteur et la batterie uniquement dans une zone connue comme non dangereuse.
- Utilisez uniquement la batterie au lithium de mPower, pièce No. 1.17.02.0002 (3.6V, 2700mAh, taille AA) ou celle de EVE Énergie Cie., Lté, pièce No. ER14505.
- Cet instrument n'a pas été testé dans une atmosphère explosive gaz / air ayant une concentration en oxygène supérieure à 21%.
- La substitution de composants compromettra l'aptitude à la sécurité intrinsèque.
- La substitution des composants annulera la garantie.
- Il est recommandé de tester avec un gaz de concentration connu pour confirmer que l'instrument fonctionne correctement avant de l'utiliser.
- Avant de l'utiliser, assurez-vous que le film ESD sur l'écran n'est pas endommagé ou épluché.

Proper Product Disposal at The End Of Life



The Waste Electrical and Electronic Equipment(WEEE) directive (2002/96/EC) is intended to promote recycling of electrical and electronic equipment and their components at end of life . This symbol (crossed-out wheeled bin) indicates separate collection of waste electrical and electronic equipment in the EU countries. This product may contain one or more Nickel-metal hydride (NiMH), Lithium-ion, or Alkaline batteries. Specific battery information is given in this user guide. Batteries must be recycled or disposed of properly. At the end of its life, this product must undergo separate collection and recycling from general or household waste. Please use the return and collection system available in your country for the disposal of this product.

General Information

UNI (MP100) is a single sensor, portable, personal toxic gas monitor. It displays gas concentration continuously on a big segment LCD. It also monitors STEL, TWA, peak and min (for O₂ only) value of the gas and can be displayed on demand.

High, Low, STEL&TWA alarm threshold values are configurable. The shell is made of high strength, durable material. Two key operation, simple to use. Sensor and battery can be replaced easily. Calibration is also very convenient.

User Interface

1. Audible Alarm Port
2. LED alarm window
3. LCD
4. Left Key (Confirm/Number increasing)
5. Right Key (Power/ Cursor moving)
6. Alligator clip
7. Sensor
8. Vibrator



Display

1. Gas name, includes: CO, H₂S, SO₂, O₂, VOC
2. Question mark
3. OK
4. Gas unit, includes: x10⁻⁶, ppm, %, mg/m³, μmol/mol
5. Battery
6. HIGH, LOW, STEL, TWA alarm
7. Span calibration
8. Zero calibration
9. Number

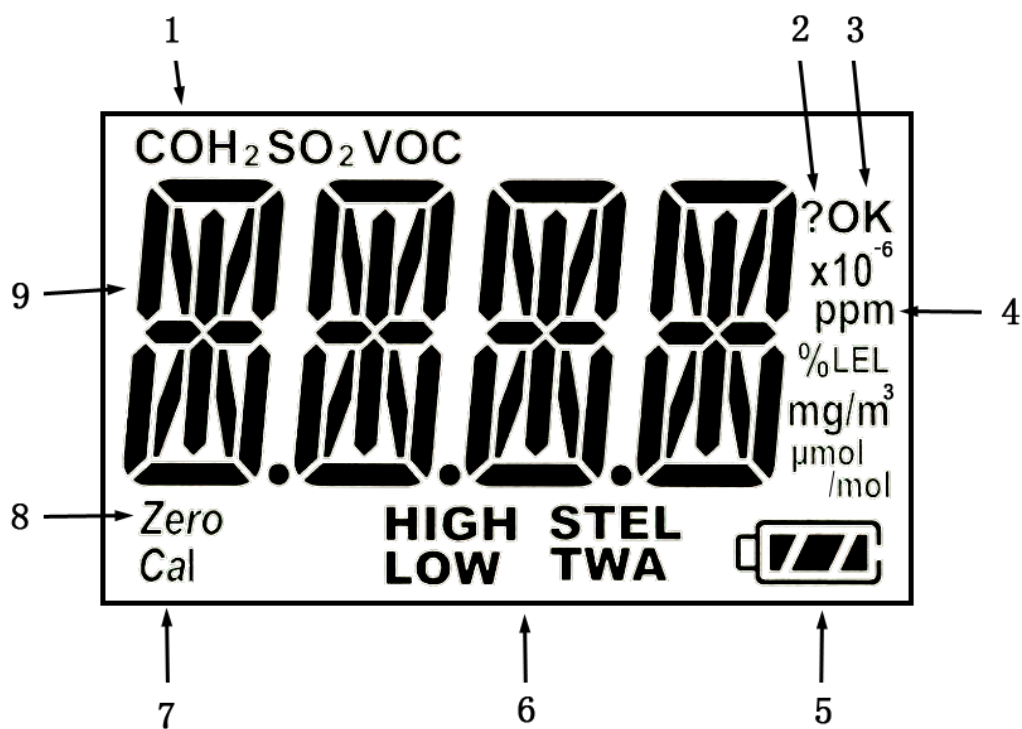

Using MP100

Turn the unit on

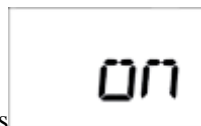

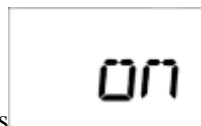
Press and hold the Right Key for 3 seconds, until LCD displays , buzzer beeps, green LED flashes, then release the button, the unit is powered on.

Warm up sequence

After powered on, the unit enter warm up and self-test sequence, show the firmware version as follows:

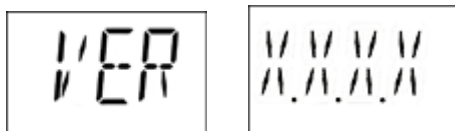

If the sensor is not able to be identified by the instrument or is not installed into the instrument,



then the screen switches between  and . Otherwise, the following values will be shown accordingly:

High alarm threshold value:



Low alarm threshold value:



STEL (short-term exposure limit) alarm threshold value:



MP100 User's Guide

TWA (time-weighted average) alarm threshold value:

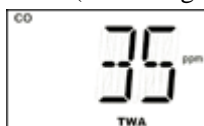

Normal mode

Real time reading

The unit enters normal mode, start monitoring gas concentration and display on the LCD screen.



User can check some other values like STEL, TWA, PEAK, and MIN (for O₂ only) by pressing the Right Key.

*Unit will return to real time reading from any other screen when there's no key action for 60 seconds.

STEL screen



TWA screen



Peak screen

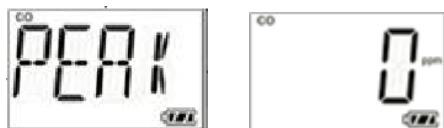

Press the Left Key to clear peak value

MP100 User's Guide



Press the Left Key again, peak value is cleared.

Min screen (for Oxygen sensor only)



Press the Left Key to clear min value



Press the Left Key again, minimum value is cleared

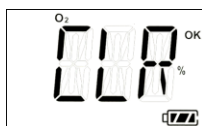

Turn the unit off

In normal display mode, press and hold the Right Key, then the unit will display a 5 second count down, LEDs will flash and buzzer will beep once per second.

Config mode

In Config mode, user can do calibration & change parameters for the unit. In general, use the Left Key to increase the number or confirm, use the Right Key to move the cursor or move to the next programming item.

Enter Config mode

Press and hold the Left Key and the Right Key together for 3 seconds, the unit enters Config mode.



The Config mode is password protected, LCD displays  to prompt enter



password. The screen displays , with one digit flashing.

MP100 User's Guide

To input password, use the Left Key to increase the number, use the Right Key to move cursor. Once all four digits are input, the cursor will move to “OK”, use the Left Key to finish password input and enter the Config mode.

If the digit input is mistaken, use the Right Key to move cursor between four digits and “OK” mark, to change the input.

*MP100 preset password is 0000

Sensor calibration

Before the unit can monitor gas correctly, it needs to know the metric, this is done by zero calibration and span calibration.

Calibration adapter

1. Calibration adapter is used to apply gas to the unit during calibration.
2. Before span calibration (in the following section), attach the Calibration Adapter over the inlet port on the front of MP100 by pressing it into place.

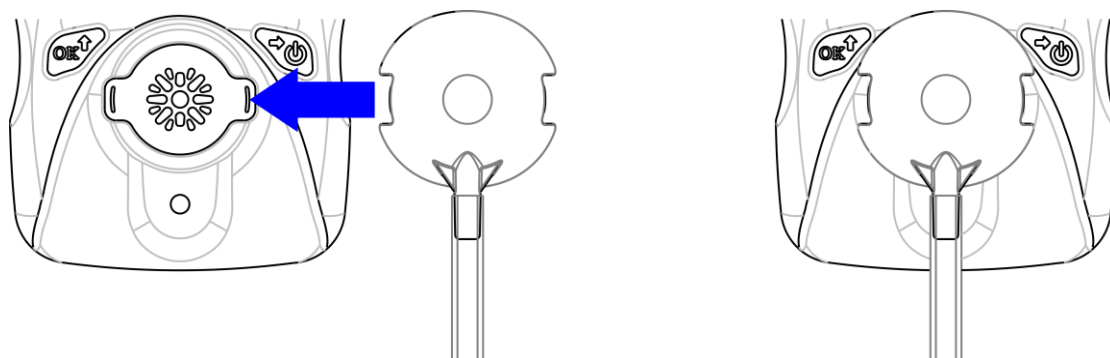

3. Open the gas cylinder valve, then press the Left Key to start the calibration count down.

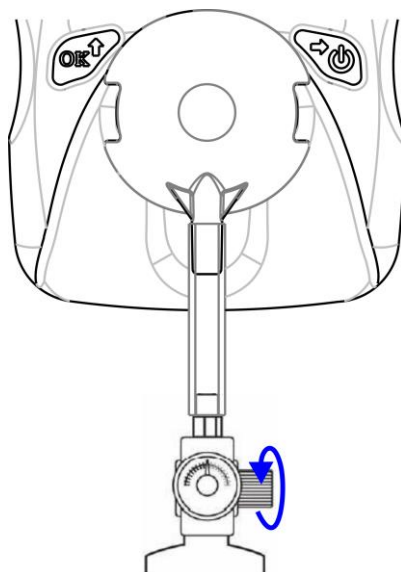

MP100 User's Guide

4. Take off the Calibration Adapter and complete calibration.

When monitoring, never operate the MP100 with the Calibration Adaptor attached. The MP100's sensor operates by diffusion. If the Calibration Adapter is attached during normal operation, inconsistent and lower-than-normal readings will occur because of decreased concentration of the gas being monitored.

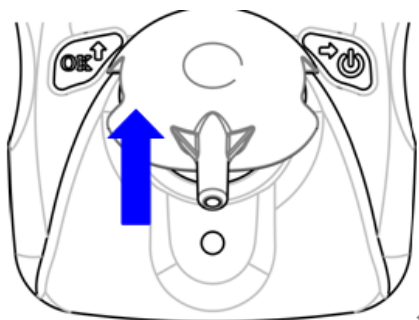

Zero calibration

Zero calibration is to set the base line for the sensor, it is done in fresh air. When LCD

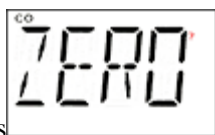

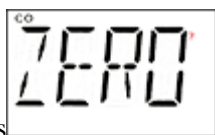
displays , press the Left Key to start zero calibration. The unit will start a 15 second count-down, after the count-down is finished, zero calibration result will be displayed on

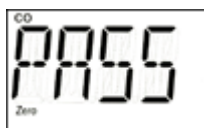

the LCD, pass



or fail

If user does not want to do zero calibration, during the 15 seconds count, press the Right Key,



LCD displays , zero calibration is aborted.

Span calibration

Span calibration is to set the metric of the sensor to the gas, it is done with a known concentration

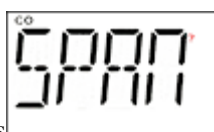

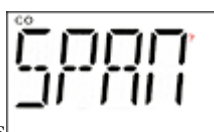
gas. When LCD displays , apply the known gas to the unit, then press the Left Key to start span calibration. Unit will start count-down, the count-down time depends on

MP100 User's Guide

different sensors (normally 60 seconds), after count-down is finished, span calibration result will



be displayed on the LCD, pass or fail.

If user does not want to do span calibration during count-down, press the Right Key, LCD



displays, span calibration is aborted.

Bump test

Bump test is to check if sensor and alarm devices are working properly, it is done with a known



concentration gas. When LCD displays, apply the known gas to the unit, then

press the Left Key to start bump test. Unit will start count-down, the count-down time depends on different sensors (normally 45 seconds), after count-down is finished, bump test result will be



displayed on the LCD, pass or fail.

If user does not want to do bump test during count-down, press the Right Key, LCD

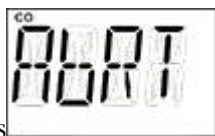

displays, bump test is aborted.

Change alarm limit

All the preset alarm limits, High, Low, STEL & TWA can be changed. When LCD displays:

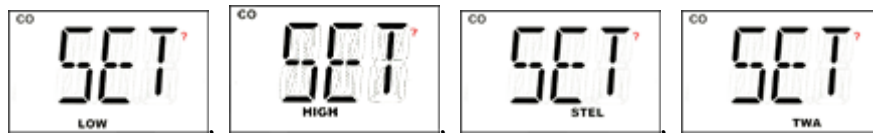

, press the Left Key to change the corresponding alarm limit, the value change process is similar.



First the current setting value is displayed, with the first digit flashing:

MP100 User's Guide



Use the Left Key to increase the current digit, cycle from 0 to 9.



Use the Right Key to move cursor to the next digit:



After all digits are done, use the Right Key to move cursor to “OK” symbol, press the Left Key to confirm the changing.

* MP100 will show “Err”, if the input data is invalid as follows,

- Low alarm setting is bigger than high alarm setting.
- High alarm setting is smaller than low alarm setting.
- Input data is bigger than measuring range.

Change bump/cal interval

The bump and cal interval can also be changed. When LCD switches between:



and



and



, press the Left

Key to change the corresponding interval range, the value change process is similar.



First the current setting value is displayed, with the first digit flashing:



Use the Left Key to increase the current digit, cycle from 0 to 9.



Use the Right Key to move cursor to the next digit:



After all digits are done, use the Right Key to move cursor to “OK” symbol,

MP100 User's Guide

press the Left Key to confirm the changing.

* MP100 will show “Err”, if the input data is out of valid range:0~180 day(s).

Change span value

The span calibration preset value can also be changed, the change process is similar with the alarm limit. But the new span will not take effect until user successfully completes a span calibration next time.

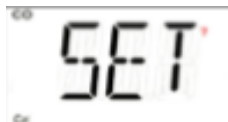

*MP100 will show “Err”, if the input data is invalid as follows:

- Span setting is smaller than 5% measuring range or bigger than measuring range.
- For Oxygen sensor, span setting is bigger than 19.0 .

Change display unit

MP100 supports different gas units, to change gas unit, when LCD switches between



, press the Left Key to change gas unit. The supported units for current sensor are all displayed on the LCD, the current selected unit is blinking. Use the Right Key to change unit, use the Left Key to confirm selected gas unit.

Vibrator enable/disable

The vibrator consumes a lot of power, it can be disabled to save battery power, to extend the battery life.





When LCD switches between , press the Left Key to change the vibrator enable/disable status. The current vibrator status is displayed on the LCD,





switching between if the vibrator is enabled, or

MP100 User's Guide

switching between  and , if the vibrator is disabled. Use the Right Key to change the enable/disable status, and use the Left Key to confirm the change.





Power on zero enable/disable

Sensor base line may have some changes due to the environment (temperature, humidity), that will require a zero calibration. MP100 can do zero calibration every time the unit is powered on; this feature can be enabled/disabled.

When LCD switches between  and , press the Left Key to go to change power on zero calibrations enable/disable status. The current enable/disable status is displayed on the LCD, use the Right Key to change, use the Left Key to confirm the change.

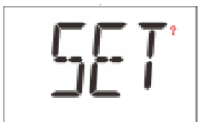
Fast power on enable/disable

If fast startup is enabled, the screens showing High/Low/STEL/TWA alarm threshold value will be skipped during warm up sequence.

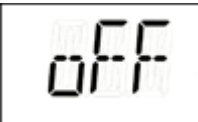
When LCD switches between  and , press the Left Key to change fast startup enable/disable status. The status is displayed on the LCD, switching between  and  if the fast startup is enabled, or switching between  and  if the fast startup is disabled. Use the Right Key to change the enable/disable status, use the Left Key to confirm the change.

Reset config

If the unit parameter is incorrect and user does not know how to set them back, user can use reset config to make all the parameters back to factory default.

MP100 User's Guide

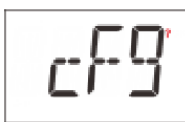

When LCD switches between  and , press the Left Key to enter config reset menu, press the Left Key to confirm config reset.

Exit Config mode

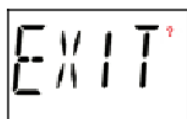

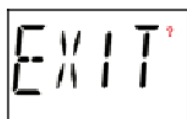
When LCD displays , press the Left Key exit from Config mode back to normal mode.

Maintenance





Maintenance should be performed only by a qualified person who has proper training and fully understands the contents of the manual.

Replace the battery

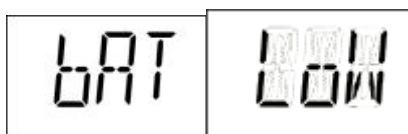

When the battery's charge is low, LCD displays , battery low alarm will be triggered once every minute. User needs to replace the battery.



When battery is dead, LCD displays  , battery dead alarm will be triggered once every second. User needs to replace the battery.

To replace battery:

- 1) Turn off the MP100.
- 2) Place the MP100 face down on a soft surface.
- 3) Use a T10 Torx screwdriver to loosen each of the four screws by turning them counterclockwise.
- 4) Remove the top cover after carefully unplugging the buzzer connector.
- 5) Slide the battery out of its compartment.
- 6) Place the new battery into the compartment with its "+" end oriented toward the "+" on the

MP100 User's Guide

printed circuit board.

- 7) Plug in the buzzer connector and reinstall the top cover.
- 8) Install the screws in back cover. Be careful to not overtighten the screws.

Replace the sensor filter

A “peel-and-stick” filter should be used on the MP100 in order to keep debris from fouling the sensor. Sheets of 5 filters are available. When the filter appears dirty, replace it with a new one and dispose of the dirty filter.

- 1) Turn off the MP100.
- 2) Place the MP100 face down on a soft surface.
- 3) Use a T10 Torx screwdriver to loosen each of the four screws by turning them counterclockwise.
- 4) Remove the top cover after carefully unplugging the buzzer connector.
- 5) Peel a filter from the sheet and center it over the sensor. Gently press down.
- 6) Plug in the buzzer connector and reinstall the top cover.
- 7) Install the screws in back cover. Be careful to not overtighten the screws.

Replace the sensor

MP100 models are designed so that you can easily change the sensor.

- 1) Turn off the unit.
- 2) Place the MP100 face down on a soft surface.
- 3) Use a T10 Torx screwdriver to loosen each of the four screws by turning them counterclockwise.
- 4) Remove the top cover after carefully unplugging the buzzer connector.
- 5) Replace the old sensor with a new one. Make sure the pins are not bent or corroded . Align the pins to the corresponding holes and push the sensor straight in . The sensor should fit flush against the printed circuit board.
- 6) Plug in the buzzer connector and reinstall the top cover.
- 7) Install the screws in back cover. Be careful to not overtighten the screws.



Sensors are not interchangeable. Use only mPower sensors, and use only the sensor type specified for your MP100 monitor. Use of non-mPower components will void the warranty and can compromise the safe performance of this product.

MP100 User's Guide

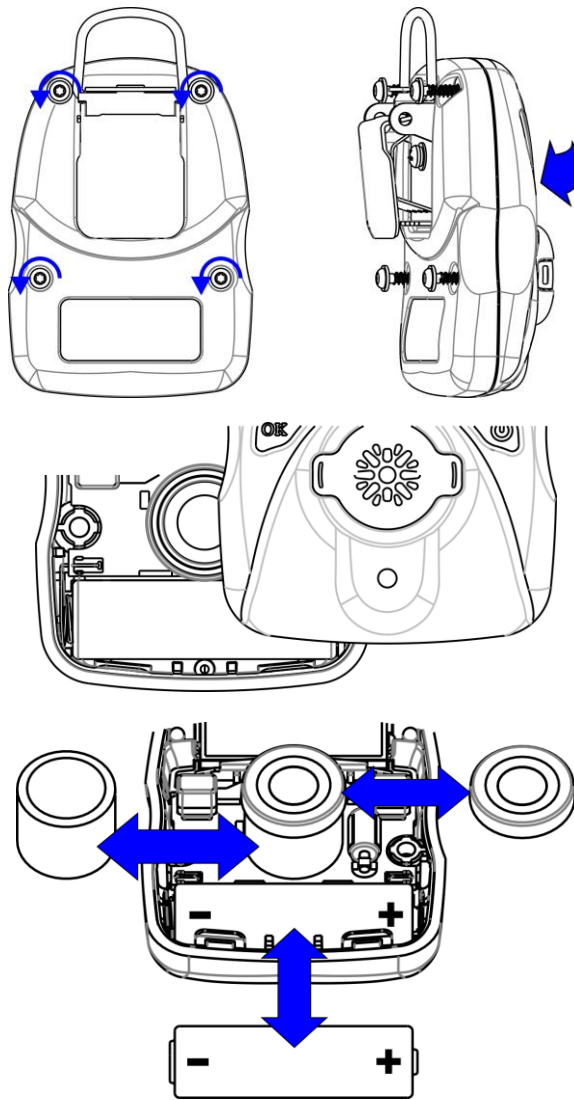

*Filter need to be replaced when it becomes discolored, clogged with particles or draws in liquid, otherwise it will contaminate sensor and void warranty.

Caution

- **Change battery only in area known to be non-hazardous.**
- **Use only mPower battery, PN: 1.17.02.0002 or part No. ER14505 cell manufactured by EVE Energy Co., LTD.**

Attention

- **Changez la batterie uniquement dans une zone connue pour être non dangereuse.**
- **Utilisez uniquement la batterie au lithium de mPower, pièce No. 1.17.02.0002 (3.6V, 2700mAh, taille AA) ou celle de EVE Énergie Cie., Lté, pièce No. ER14505.**

Ordering information

Kit Package

- MP100 instrument (with sensor, AA size lithium battery and alligator clip)
- Quick start guide
- Calibration adapter

Calibration Kits (Optional)

- Test gas (for sensor as specified)
- Gas regulator with flow controller
- Hard transport case
- Multi-unit charging and calibration station

Year of manufacturing

To identify the year of manufacturing, please refer to the serial number of the instrument.

The fifth to sixth digit in the serial number indicates the year of manufacturing. 00~99 indicates the manufacturing year is 2000 to 2099.

MP100 User's Guide

Specifications

Size	3.46 x 2.44 x 1.3 in. (88 x 62 x 33mm)
Weight	4.4 oz. (125g)
Temperature	-4°F ~ 122°F (-20°C ~ 50°C)
Humidity	5 ~ 95% relative humidity(non-condensing)
Alarm type	High alarm, low alarm, STEL alarm & TWA alarm adjustable. Over range alarm, battery low alarm.
Alarm signal	Audible: 90dB @ 30cm Visual: Bright red LED Sense: Built in vibrator
Calibration	2 point calibration, zero and span, power on zero (need user confirm).
Event log	Up to 10 alarm events
Response time(T90)	20 seconds(only for CO/H ₂ S/O ₂)
IP rating	IP67
EMI/RFI	Compliant with EMC 2004/108/EC
Certifications	Intrinsic Safety: UL/CUL: Class I, Group A, B, C, D Class II, Group E,F,G Class III ,Hazardous Locations T4, -20° C ≤ Tamb ≤ +50° C
Battery	Replaceable AA size Lithium battery, 3 years if used within specs
Sensor	CO/H ₂ S expected operating life 5 years in air, others 2 years
Warranty	2 year warranty for CO, H ₂ S, O ₂ and SO ₂ , 1 year for the others.

Sensor configuration

Sensor	Range (ppm)	Resolution (ppm)	Span (ppm)	Low (ppm)	High (ppm)	STEL (ppm)	TWA (ppm)	Panel Ring	T90(s)
CO	0-1999	1	100	35	200	100	35	Red	20
	0-1000	1	100	35	200	100	35		20
	0-500	1	50	35	200	100	35		20
H ₂ S	0~50	0.1	25	10	20	15	10	Light Blue	20
	0-100	0.1	25	10	20	15	10		20
	0~200	0.1	25	10	20	15	10		20
	0~1000	1	25	10	20	15	10		30
NH ₃	0-50	1	50	25	50	35	25	Orange	150
Cl ₂	0-10	0.1	10	0.5	5	1	0.5	Orange	30
ClO ₂	0-1	0.01	0.5	0.2	0.5	0.3	0.1	Orange	120
HCN	0-100	1	10	4.7	50	4.7	4.7	Orange	200
NO	0-250	1	25	25	50	25	25	Orange	30
NO ₂	0-20	0.1	5	1	10	1	1	Orange	30
PH ₃	0-20	0.01	5	1	2	1	0.3	Orange	60
SO ₂	0-20	0.1	5	2	10	5	2	Orange	15
ETO	0-100	0.1	10	1	5	5	1	Orange	120
	0-200	0.1	10	5	10	5	1	Orange	120
O ₃	0-1	0.02	1	0.1	0.2	0.1	0.1	Orange	60
HF	0-10	0.1	6	2	6	6	3	Orange	90
HCl	0-15	0.1	10	2	5	5	1	Orange	90
CH ₃ SH	0-10	0.1	5	0.5	5	0.5	0.5	Orange	35
C ₂ H ₄ O	0-20	0.1	5	2	10	5	2	Orange	120

Sensor	Range (%)	Resolution (%)	Span (%)	Low (%)	High (%)	STEL (%)	TWA (%)	Panel Ring	T90(s)
O ₂	0 - 25	0.1	18	19.5	23.5	-	-	Dark	20
	0 - 30	0.1	18	19.5	23.5	-	-	Blue	20









Caution







Use only mPower sensors.

Call for Availability.

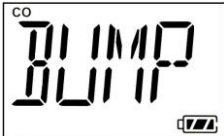
Alarm signal summary

LCD Display	Reason/Alarm Signals
	<p>Over range:</p> <ul style="list-style-type: none"> Buzzer 3 beeps per second LED 3 flashes per second 1 vibration per second “OVER” and “500” 1 flash per second
	<p>High alarm:</p> <ul style="list-style-type: none"> Buzzer 3 beeps per second LED 3 flashes per second 1 vibration per second “HIGH” 2 flashes per second
	<p>Low alarm:</p> <ul style="list-style-type: none"> Buzzer 2 beeps per second LED 2 flashes per second 1 vibration per second “LOW” 2 flashes per second
	<p>STEL alarm:</p> <ul style="list-style-type: none"> Buzzer 1 beeps per second LED 1 flash per second 1 vibration per second “STEL” 2 flashes per second
	<p>TWA alarm:</p> <ul style="list-style-type: none"> Buzzer 1 beep per second LED 1 flash per second 1 vibration per second “TWA” 2 flashes per second
	<p>Negative drift alarm :</p> <ul style="list-style-type: none"> Buzzer 1 beep per second LED 1 flash per second 1 vibration per second

MP100 User's Guide

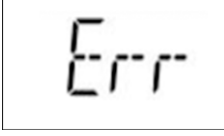
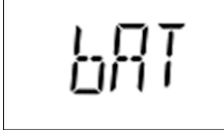
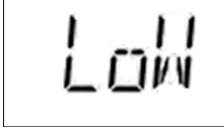
 	<p>Bump over due alarm:</p> <p>Buzzer 1 beep per minute LED 1 flash per minute 1 vibration per minute</p>
 	<p>Cal over due alarm:</p> <p>Buzzer 1 beep per minute LED 1 flash per minute 1 vibration per minute</p>
	<p>Battery empty alarm:</p> <p>Buzzer 1 beep per minute LED 1 flash per minute 1 vibration per minute  1 flash per minute</p>
 	<p>Sensor error:</p> <p>Buzzer 1 beep per second LED 1 flash per second “SEN Err”1 flash per second</p>
 	<p>Battery low alarm:</p> <p>Buzzer 1 beep per second LED 1 flash per second “bAT LoW”1 flash per second</p>

Trouble shooting

Problem	Possible reason	Solution
Can not turn on unit	Battery not installed	Install battery.
	Depleted or defective battery	Replace battery.
Reading abnormally low	Calibration Adapter is attached.	Remove Calibration Adapter.
	Incorrect calibration.	Calibrate the MP100.
Buzzer, LED, or vibration alarm inoperative	Bad buzzer, LEDs, or vibration alarm.	Call authorized service center.
	Blocked alarm port	Unblock alarm port.

MP100 User's Guide



mPower Electronics Inc.

3046 Scott Blvd

Santa Clara, CA 95054

www.mpowerinc.com

Tech Support: info@mpowerinc.com