

SharpEye™

UV/IR Flame Simulator

Model FS-1200

Installation Instructions



Document ref: TM380102, Rev. (D), March 2016



218 Little Falls Rd., Cedar Grove, NJ 07009, USA
Phone: +1 (973) 239 8398 Fax: +1 (973) 239 7614
Web-Site: www.spectrex.net; Email: spectrex@spectrex.net

Legal Notice

The SharpEye Flame Simulator described in this document is the property of Spectrex, Inc.

No part of the hardware, software or documentation may be reproduced, transmitted, transcribed, stored in a retrieval system or translated into any language or computer language, in any form or by any means, without prior written permission of Spectrex, Inc.

While great efforts have been made to assure the accuracy and clarity of this document, Spectrex, Inc. assumes no liability resulting from any omissions in this document, or from misuse of the information obtained herein. The information in this document has been carefully checked and is believed to be entirely reliable with all of the necessary information included. Spectrex Inc. reserves the right to make changes to any products described herein to improve reliability, function, or design, and reserves the right to revise this document and make changes from time to time in content hereof with no obligation to notify any persons of revisions or changes. Spectrex, Inc. does not assume any liability arising out of the application or any use of any product or circuit described herein; neither does it convey license under its patent rights or the rights of others



Warning: This manual should be read carefully by all individuals who have or will have responsibility for using, maintaining or servicing the product.

The Simulator is not field-repairable due to the meticulous alignment and calibration of the sensors and the respective circuits. Do not attempt to modify or repair the internal circuits or change their settings, as this will impair the system's performance and void the Spectrex, Inc. Product warranty.

Warranty

SPECTREX INC. Agrees to extend to Purchaser/Distributor a warranty on the SPECTREX supplied components of the SharpEye products. SPECTREX warrants to Purchaser/Distributor that the products are free from defects in materials and workmanship for a period of one (1) year, commencing from the date of shipment to Purchaser/Distributor. SPECTREX expressly excludes damage incurred in transit from the factory or other damage due to abuse, misuse, improper installation, or lack of maintenance or "Act of God" which are above and beyond its control. SPECTREX will, upon receipt of any defective product, transportation prepaid, repair or replace it at its sole discretion if found to have been defective when shipped. Said repair or replacement is SPECTREX'S sole liability under this warranty and SPECTREX'S liability shall be limited to repair or replacement of the component found defective and shall not include any liability for consequential or other damages. The customer is responsible for all freight charges and taxes due on shipments both ways. This warranty is exclusive of all other warranties express or implied.

Release History

Rev	Date	Revision History	Prepared by	Approved by
0	December 2015	First Release	Ian Buchanan	Eric Zinn
A	December 2015	Second Release	Ian Buchanan	Eric Zinn
B	January 2016	Third Release	Ian Buchanan	Eric Zinn
C	March 2016	Forth Release	Ian Buchanan	Eric Zinn
D	April 2016	Fifth Release	Ian Buchanan	Eric Zinn

About this Guide

This guide describes the SharpEye Flame Simulators and their features and provides instructions on how to operate and maintain the detector.

This guide includes the following chapters and appendixes:

- **Chapter 1, Introduction**, provides a general overview of the product, principles of operation, and performance considerations.
- **Chapter 2, Operation Instructions**, describes how to operate the simulator, including instructions regarding the replacement and charging of the battery.

Table of Contents

1	Introduction	3
1.1	Model and Types	4
1.2	Features and Benefits	4
1.3	Principles of Operation	4
1.4	Simulator Status	5
1.5	Product Certification	5
1.6	Simulator Structure	6
1.7	Certification Instructions	8
2	Operation Instructions	11
2.1	Ordering Information	11
2.2	Unpacking	11
2.3	Operating Instructions	12
2.4	Detection Ranges per Detector/ Flame Simulator	13
2.5	Charging the Battery	14
2.6	Maintenance	15
2.7	Troubleshooting	16
2.8	Technical Specifications	16
2.8.1	General Specifications	16
2.8.2	Electrical Specifications	16
2.8.3	Physical Specifications	17
2.8.4	EMI Compatibility	17
	Technical Support	18

List of Figures

Figure 1: Flame Simulator Side View	6
Figure 2: Flame Simulator Rear View	7
Figure 3: Flame Simulator Front View	7
Figure 4: Flame Simulator Battery Replacement	15

List of Tables

Table 1: Flame Simulator Compatability	12
Table 2: Detection Ranges per Detector / Flame Simulator	13

1 Introduction

To comply with local standards and jurisdictional authorities, "end-to-end" loop testing of Fire Protection Alarm Systems, including detectors, should be performed periodically. Many Safety Authorities and Plant Managers of high value / high risk assets and facilities insist on quarterly "end-to-end" testing of their entire Fire Protection Systems using an external Flame Simulator.

Spectrex Flame Simulators emit electromagnetic radiation in a unique sequential pattern corresponding to and recognizable as fire by the specific SharpEye Flame Detector model. This allows the detector to be tested under real fire conditions without the associated risks of an open flame. Spectrex Flame Simulators are ATEX certified EExd for use in Zone 1 and Zone 2 hazardous areas and are powered by rechargeable Lithium Ion batteries. When fully charged, the Flame Simulator will operate for at least 100 tests without recharging.

Using an external, portable Spectrex Flame Simulator is the best means to perform a full, functional "end-to-end" test of the Detector and the Fire Protection System without the need to start a real fire (which is not permitted in hazardous areas and can be dangerous in non-hazardous areas). The Spectrex Flame Simulator is the only non-hazardous and safe method to test the flame detector's sensors, internal electronics, alarm activation software, cleanliness of the viewing window/lens, wiring integrity, actual relay activation, and proper functionality of any other outputs used (mA, RS485, HART).

1.1 Model and Types

The FS-1200 Flame Simulator is compatible with different detector types:

Simulator	P/N	Compatible with:
UV/IR Flame Simulator	FS-1200	40/40L-LB, 40/40L4-L4B, 40/40U-UB, 40/40UFL 20/20ML 20/20LB, 20/20U-UB

1.2 Features and Benefits

- Used for maintenance and testing of Flame Detectors
- Ability to activate the flame detector from a distance of up to 10m
- Rechargeable battery included
- Operates at least 100 tests before recharging the battery

1.3 Principles of Operation

The **FS-1200** includes a halogen lamp that emits UV and IR energy. This energy is accumulated by a reflector directed towards the detector.

The **FS-1200** does not include a laser diode, only a mechanical sight, as the user can see the spot from the simulator and should aim the spot at the center of the detector.

1.4 Simulator Status

The status is defined by the halogen light. There is no laser.

Normal Status

At normal, the light flashes for 50 seconds. The simulator cannot then be operated for 20 seconds (delay between activations).

Fault Status

If the light does not turn on, this indicates one of three possible faults:

- a. Low Battery
- b. Halogen Fault
- c. Total Failure

1.5 Product Certification

The Flame Simulator is certified to ATEX and IECEx:

Ex II 2 G

Ex d ib op is IIB + H₂ T5 Gb

-4°F to +122°F (-20C to +50°C)

This product is suitable for use in hazardous zones 1 and 2 with IIB + H₂ gas group vapor present.

1.6 Simulator Structure

The Flame Simulator is built from black coated aluminum housing. It includes:

- a. Reflector
- b. Electronic chamber
- c. Battery chamber
- d. Handle

The electronic chamber includes a PC Board with the IR or halogen lamp which is assembled on the PC Board that emits the light through sapphire window

The battery chamber includes a battery pack containing four lithium-ion batteries of total 14.8VDC and 2.2AH.

The battery pack can be replaced easily by opening the back cover. This exchange must be done in a safe area and only a Spectrex battery pack, P/N 380004 should be used.



Figure 1: Flame Simulator Side View

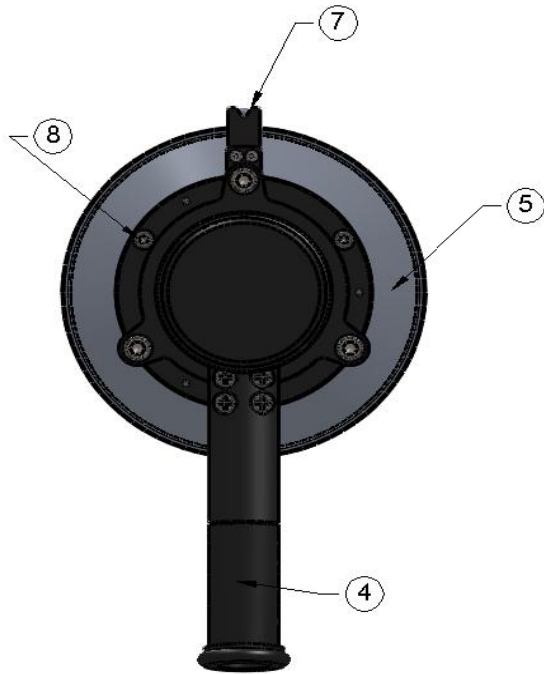

Figure 2: Flame Simulator Rear View

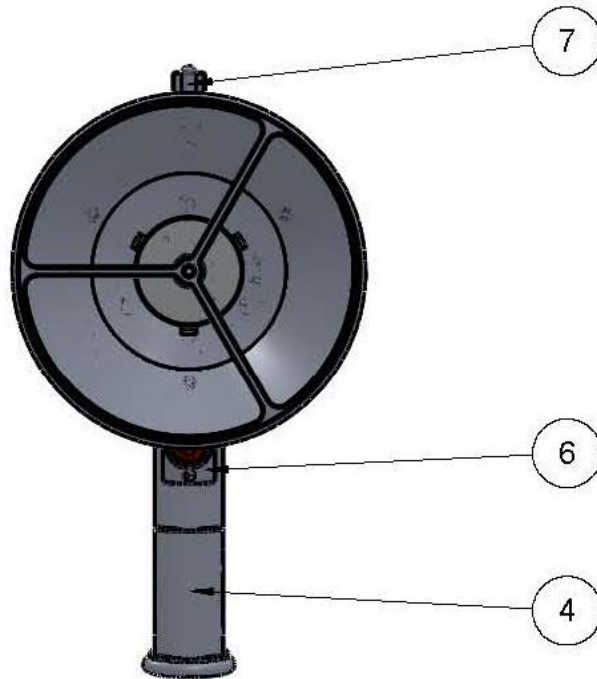

Figure 3: Flame Simulator Front View

1	Electronic Chamber	7	Sight
2	Battery Chamber	8	Back Cover Locking Screw
3	Battery Back Cover		
4	Handle		
5	Reflector		
6	Push Button		

1.7 Certification Instructions

- The marking of the equipment is:

Ex II 2 G

Ex d ib op is IIB + H₂ T5 Gb

-20°C to +50°C (-4°F to +122°F)

- The manufacturer/importer/repair is Spectrex Inc., at 218 Little Falls Road, Ceder Grove NJ, USA.
- The equipment may be used with flammable gasses and vapors with apparatus groups IIA and IIB+H₂ T5 in the ambient temperature range of -4°F to +122°F (-20°C to +50°C).
- The dimensions of the flameproof joints are other than the relevant minimum or maximum values required by table 2 of IEC/EN 60079-1:2007 for IIB + H₂, as detailed below:

Flamepath Description	Type of Joint	Minimum Width 'L' (mm)	Maximum Gap 'ic' (mm)
Joint formed by window against the enclosure	Flanged	10.75	0.02
Enclosure end-cap spigot	Cylindrical	15	0.08

Gaps shall not be machined to be any larger than the values of 'ic', and width shall not be modified to be any smaller than the values of 'L' shown in the table above.

- Inspection and maintenance of this equipment should be carried out by suitable trained personnel, in accordance with the applicable code of practice e.g. EN 60079-17.

- The equipment shall only be charged in a safe area with the batteries removed from the flameproof enclosure. The charge conditions are as follows:

Maximum charge voltage: 4.2V per cell

Maximum charge current: 2200mA

The charge voltage shall not exceed these values.

- Repair of this equipment should be carried out by suitable trained personnel, in accordance with the applicable code of practice e.g. EN 60079-19.
- The certification of this equipment relies upon the following materials used in its construction:
 - Enclosure: Aluminum 6061T6
 - Window: Sapphire glass
 - Seals: EPDM
- If the equipment is likely to come into contact with aggressive substances (described below), then it is the responsibility of the user to take suitable precautions (described below) to prevent it from being adversely affected, thus ensuring that the type of protection provided by the equipment is not compromised.
 - Aggressive substances: for example, acidic liquids gases that may attack metals or solvents that may affect polymeric materials.
 - Suitable precautions: for example, regular checks as part of routine inspections or establishing from the material's data sheets that it is resistant to specific chemicals.

2 Operation Instructions

2.1 Ordering Information

The P/N of the Flame Simulator Kit is 380114-2.

The Kit is supplied in a carry case that includes:

1. Flame Simulators FS-1200
2. Charger
3. Tool Kit
4. Technical Manual TM380102

2.2 Unpacking

Verify that you have received the following content:

- Delivery form
- Flame Simulator with integral battery
- Battery charger
- Tool keys
- User manual
- FAT forms
- EC Declaration
- Storage case

2.3 Operating Instructions

Warning: Do not open the Flame Simulator to charge the batteries or for any other reason in a hazardous area.

Caution: The following test simulates a real fire condition and may activate the extinguishing system or other alarms. If this is not desired, disconnect/inhibit them before the test and reconnect after simulation.

- a. Verify you are using the correct simulator that fits the tested detector, per the following table:

Simulator	Compatible with:
FS-1200	40/40L-LB, 40/40L4-L4B, 40/40U-UB, 40/40UFL, 20/20ML 20/20L-LB, 20/20U-UB

Table 1: Flame Simulator Compatibility

- b. Verify you are at the correct distance from the detector according to the type of detector (see 2.3), and the detector sensitivity.
- c. Aim the detector using the mechanical sight at the center of the detector. Activate the button and adjust the spot to the center of the detector.
- d. Keep the simulator aimed at the detector for up to 50 seconds until you receive an alarm.
- e. Wait 20 seconds before repeating the test.

2.4 Detection Ranges per Detector/ Flame Simulator

Model	Detector Types	Detector Sensitivity Setting	Testing Distance
FS-1200	40/40U-UB, 40/40L-LB, 20/20U-UB, 20/20L-LB, 20/20ML	50ft (15m)	20ft (6m)
	40/40L4-L4B	50ft (15m)	8ft (2.5m)
	40/40UFL	60ft (20m)	23ft (7m)

Table 2: Detection Ranges per Detector / Flame Simulator

Notes:

- The minimum distance from the detector is 30" (75cm)
- At extreme temperatures there is a 15% reduction in the testing range.



Important: Keep the Flame Simulator in a safe place when not in use.

2.5 Charging the Battery

The Flame Simulator uses Lithium Ion batteries as a rechargeable power source. When the batteries are fully charged, the simulator operates for at least 100 times without recharging. When the voltage from the batteries is lower than the required operational level, the simulator will not operate.

To Charge the Battery:

1. Place the Flame Simulator on a table in a safe area, not exceeding 40°C.
2. Release the locking screw, item 8 fig. 1.
3. Unscrew the battery back cover, item 3, fig. 1 & 4, counter-clockwise.
4. Unscrew the locking disc clockwise, item 4 fig. 4.
5. Pull out the battery, item 2, fig. 4, from the Flame Simulator.
6. Connect the battery to the charger. Verify that the charger is the one supplied with the flame simulator model FRIWO MPP15 with max. charging voltage 16.8V (4.2 V x 4) with max. current of 700mA.
7. Charge for a maximum of 2 – 3 hours, until the green LED on the charger turns on.
8. Disconnect the charger.
9. Insert the battery, item 2, fig. 4, to the Flame Simulator.
10. Screw the locking disc, item 4 fig. 4.
11. Screw the back cover, item 3 fig. 1 & 4.
12. Lock the back cover with the locking screw, item 8 in Fig. 1.

To Replace the Battery:

1. Place the Flame Simulator on a table in a safe area, not exceeding 40°C.
2. Release the locking screw, item 8 fig. 1.
3. Unscrew the battery back cover, item 3 fig. 1 & 4, counter-clockwise.
4. Unscrew the locking disc clockwise, item 4 fig. 4.
5. Pull out the battery, item 2, fig. 4, from the Flame Simulator.
6. Insert the new battery pack in the simulator housing. Use only Spectrex battery pack, P/N 380004.
7. Screw the locking disc, item 4 fig. 4.
8. Screw the back cover, item 3 in Fig. 1 & 4.
9. Lock the back cover with the locking screw, item 8 in Fig. 1.

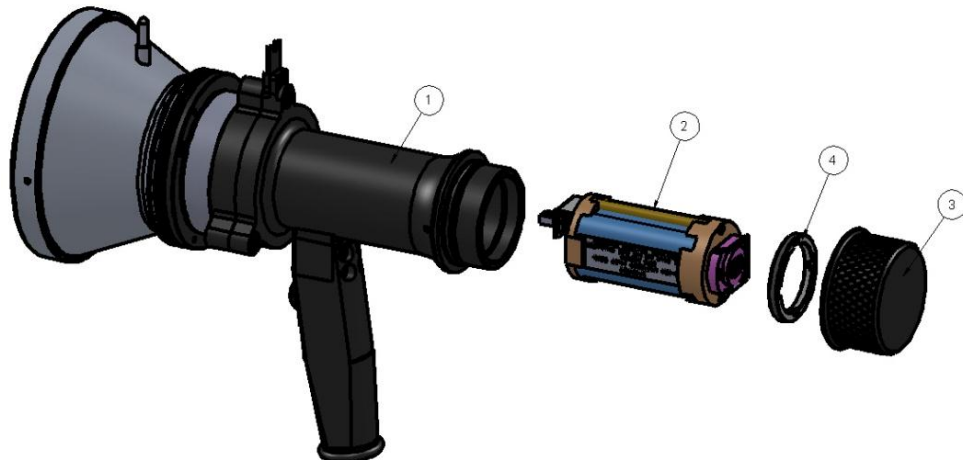

1	Simulator
2	Battery Pack
3	Back Cover
4	Locking Disc

Figure 4: Flame Simulator Battery Replacement

2.6 Maintenance

1. Ensure the Flame Simulator is charged before operation.
2. Ensure the reflector and the window are clean.
3. Before replacing the battery, ensure you have a Spectrex Battery Pack, P/N 380004
4. When the simulator is not in use, recharge at least every 6 months.



Warning: Use only Spectrex Replacement Battery Pack, P/N 380004

2.7 Troubleshooting

Model	Problem	Solution
FS-1200	The light does not turn on	<ol style="list-style-type: none">1. Recharge the battery.2. Replace the battery.3. Send the flame simulator for repair.
	Flame simulator seems to work properly but does not activate the detector	<ol style="list-style-type: none">1. Verify that you are at the correct distance.2. Verify that the flame detector is at the correct sensitivity.3. Verify that the flame detector is operating.4. Verify that the flame detector window and/or reflector are clean

2.8 Technical Specifications

2.8.1 General Specifications

Operating Temperature: +23° to +122°F (-5° to +50°C)

Vibration Protection: 1g (10-50Hz)

2.8.2 Electrical Specifications

Power: 14.8V (4 x 3.7V Rechargeable Lithium Ion Battery)

Max. Current: 4A

Battery Capacity: 2.2AH

Charging Time: 2Hr at 2A

2.8.3 Physical Specifications

Dimensions: 9 x 7.3 x 5.35 inch (230 x 185 x 136 mm)

Weight: 5.5lb (2.5kg)

Enclosure: Aluminum, heavy duty copper free, black zinc coating.

Explosion proof enclosure: ATEX and IECEx

Ex II 2 G

Ex d ib op is IIB + H₂ T5 Gb

-20°C to +50°C (-4°F to +122°F)

Water and Dust Tight: IP65

2.8.4 EMI Compatibility

Immunity Tests		
Title	Basic Standard	Level to be tested
Electrostatic discharge (ESD)	IEC 61000-4-2	6 kV/8 kV contact/air
Radiated Electromagnetic Field	IEC 61000-4-3	20 V/m (80 MHz to 1 GHz) 10 V/m (1,4 GHz to 2 GHz) 3 V/m (2,0 GHz to 2,7 GHz)
Conducted Disturbances	IEC 61000-4-6	10 Vrms (150 kHz to 80 MHz)
Immunity to main supply voltage variations	MIL-STD-1275B	

Emission Tests			
Title	Basic Standard	Level to be Tested	Class
Radiated Emission	IEC 61000-6-3,	40dbuv/m (30MHz-230MHz), 47dbuv/m(230MHz-1GHz)	Like Class B of EN 55022

Technical Support

For all technical assistance or support, contact:



218 Little Falls Road
Cedar Grove, NJ 07009, USA

Tel: +1 (973) 239 8398
Fax: +1 (973) 239 7614
Email: spectrex@spectrex.net
Web-site: www.spectrex.net

Your Local Office:

SPECTREX INC.

Texas (USA)

Mr. Jay Cooley, Regional Sales Manager
16203 Park Row, Suite 150
Houston, Texas 77084
USA
Phone: +1 (832) 321 5229
Email: jay@spectrex.net

Europe

Mr. Ian Buchanan, Regional Manager
6 Applecross Road
Glasgow G66 3TJ
United Kingdom
Phone: +44 (0) 141 578 0693
Email: ian@spectrex.net

Far East

Mr. Deryk Walker, Regional Sales Manager
59 Fen Ji Hu, Danshui
Taipei County 25163
Taiwan (ROC)
Phone: +886 2 8626 2893
Mobile: +886 926 664 232
Email: deryk@spectrex.net