

SharpEye™

Ultra Fast UV/IR Flame Detector

Model 20/20F

User and Maintenance Manual

TM756100 Rev A, July 2005



ATEX Approved

Ex II 2G

EExd IIB + H₂ T5

EExde IIB + H₂ T5



SPECTREX INC.

218 Little Falls Rd., Cedar Grove, NJ 07009 USA;

Phone: +1 (973) 239 8398 Fax: +1 (973) 239 7614

Web-Site: www.spectrex-inc.com ; Email: spectrex@spectrex-inc.com

The SharpEye Optical Flame Detector described in this document is the property of Spectrex, Inc.

No part of the hardware, software or documentation may be reproduced, transmitted, transcribed, stored in a retrieval system, or translated into any language or computer language, in any form or by any means, without prior written permission of Spectrex, Inc.

While great efforts have been made to assure the accuracy and clarity of this document, Spectrex, Inc. assumes no liability resulting from any omissions in this document, or from misuse of the information obtained herein. The information in this document has been carefully checked and is believed to be entirely reliable with all of the necessary information included. Spectrex Inc. reserves the right to make changes to any products described herein to improve reliability, function, or design, and reserves the right to revise this document and make changes from time to time in content hereof with no obligation to notify any persons of revisions or changes. Spectrex, Inc. does not assume any liability arising out of the application or any use of any product or circuit described herein; neither does it convey license under its patent rights or the rights of others.

Warning:

This manual should be carefully read by all individuals who have or will have responsibility for using, maintaining or servicing the product.

The Detector is not field-repairable due to the meticulous alignment and calibration of the sensors and the respective circuits. Do not attempt to modify or repair the internal circuits or change their settings, as this will impair the system's performance and void the Spectrex, Inc. Product warranty.

TABLE OF CONTENT

1. Scope	1
1.1 Product Overview	1
1.2 Document Overview.....	1
2. Technical Description.....	2
2.1 Principles Of Operation.....	2
2.2 Sensing Elements	2
2.3 Detection Levels	3
2.4 Detector Structure	3
2.5 System Configuration.....	3
2.6 Detector Type	3
2.7 Product Marking.....	3
3. Performance	6
3.1 Detection Sensitivity.....	6
3.2 Cone Of Vision.....	8
3.3 False Alarms.....	9
4. Operation.....	10
4.1 Visual Indications	10
4.2 Output Signals.....	10
5. Technical Specifications	10
5.1 Electrical Specifications	10
5.2 Mechanical Specifications	11
5.3 Environmental Specifications.....	12
6. Installation Instructions	13
6.1 Introduction.....	13
6.2 General Considerations	13
6.3 Preparations For Installation.....	14
6.4 Conduit Installation.....	14
6.5 Detector Mounting	15
6.5.1 Swivel Mount Kit.....	15
6.5.2 Swivel installation (Figure 4a and 4b).....	15
6.6 Wiring (Refer to Fig. 5)	18
6.7 Terminal Wiring (Figures 6,7)	19
7. Operating Instructions	22
7.1 Scope.....	22
7.2 Power-Up	22
7.3 Testing With Fire Simulator (See Appendix D).....	22
7.4 Safety Precautions	23
8. Maintenance Instructions	24
8.1 Scope.....	24
8.2 Maintenance Tools and Personnel.....	24
8.3 Preventive Maintenance Procedures	24
8.4 Periodic Maintenance Procedures.....	24
8.4.1 Power Up Procedure	24
8.4.2 Functional Test Procedure.....	24

8.5 Maintenance Records.....	25
8.6 Troubleshooting	25
8.6.1 Fault Indication.....	25
8.6.2 False Alarm or Warning Indication	25
Appendix A - Wire Selection Tables	27
Appendix B. Typical Wiring Configurations	29
Appendix C. Mounting the “EExde approved” version.....	31
Appendix D. Long Range UV/IR Fire Simulator	35

LIST OF FIGURES

<i>Figure 1. Flame Detector Assembly - Outline Drawing.....</i>	<i>4</i>
<i>Figure 2. Flame Detector Assembly - Schematic Section</i>	<i>5</i>
<i>Figure 3. Horizontal and Vertical Fields of View</i>	<i>8</i>
<i>Figure 4.a. UV/IR Detector and Swivel Mount Assembly</i>	<i>16</i>
<i>Figure 4.b. Swivel Mount Assembly.....</i>	<i>17</i>
<i>Figure 5. UV/IR Flame Detector with Cover Removed.....</i>	<i>20</i>
<i>Figure 6. Flame Detector Assembly - Wiring Diagram</i>	<i>21</i>
<i>Figure 7. Typical Wiring Diagram for Four-Wire Controller</i>	<i>29</i>
<i>Figure 8: Flame Detector Assembly - Wiring Diagram.....</i>	<i>33</i>
<i>Figure 9: Flame Detector Assembly - Wiring Diagram (“de version”).....</i>	<i>34</i>
<i>Figure 10: Fire Simulator.....</i>	<i>35</i>
<i>Figure 11: UV/IR Detector Target Point.....</i>	<i>36</i>

LIST OF TABLES

<i>Table 1. Response Sensitivity Ranges</i>	<i>7</i>
<i>Table 2: Response to Pyrotechnic Material.....</i>	<i>7</i>
<i>Table 3. Immunity to False Alarm Faults.....</i>	<i>9</i>
<i>Table 4. Dry Contacts Relays Ratings</i>	<i>11</i>
<i>Table 5: Mounting according to US Version</i>	<i>15</i>
<i>Table 6: Mounting according to EU Version</i>	<i>15</i>
<i>Table 7. Maximum DC resistance at 68°F for copper wire.....</i>	<i>27</i>
<i>Table 8. Wiring length in feet (meter).....</i>	<i>27</i>

1. Scope

1.1 Product Overview

The Flame detector Model 20/20F, with its ultra fast response, is designed to meet the two most important requirements for survivability: Fast Response Time (less than 5 milliseconds) and high reliability (immune to false alarms).

The 20/20-F is sensitive to radiation in two frequency ranges of the electromagnetic spectrum: the infrared and the ultraviolet. Only simultaneous sensing off these two radiation ranges will result in a detector output pulse. The simultaneous occurrence of radiation in these two ranges is a characteristic of fire only, thus greatly reducing the probability of a false alarm.

The 20/20-F has a continuously self-adjusting, pre-set level of activation for detection of fire or vapor explosion. Its level of sensitivity is maintained over a wide temperature range, and is independent of background radiation.

1.2 Document Overview

This manual describes the detector and its features. It describes instructions on the installation, operation and maintenance.

This manual is divided into several parts. Each part is contained in a separate chapter as follows:

- Chapter 1. **Scope.** A general introduction and overview of the product and the Manual with a brief description of its content.
- Chapter 2. **Technical Description** - the detector's theory of operation.
- Chapter 3. **Performance** - the detector features and capabilities.
- Chapter 4. **Operation** modes, user interface and indications.
- Chapter 5. **Technical Specifications** Detector's electrical, mechanical and environmental specifications.
- Chapter 6. **Installation Instructions** including wiring and mode setting.
- Chapter 7. **Operating Instructions** and power-up procedures.
- Chapter 8. **Maintenance Instructions** and support procedures.
- Appendix A. **Wiring Selection Tables** for electrical wire selection according to installation configuration.
- Appendix B. **Typical Wiring Configurations** provides wiring diagrams for installation.
- Appendix C. **Mounting the "EExde approved" version**
- Appendix D. **Long Range UV/IR Fire Simulator**

2. Technical Description

- **Detection Range:** Up to 20 ft (6m) for a 1ft x 1ft (0.3m x 0.3m) Gasoline fire.
- **Ultra High Immunity to False Alarm** (see section. 3.3.).
- **Advanced Digital Processing of the Dynamic Characteristics of Fire:** Flickering and threshold
- **Dual Spectrum:** UV and IR radiation
- **Solar Blind**
- **Electrical Interface:** Dry contact relays
- **UV/IR Dual Spectrum Design**
- **Fast Response Time:** Less than 5 milliseconds
- **Built In Sensitivity Compensator**
- **Filed of View:** 90° Horizontal
70° Vertical
- **Explosion Proof:** ATEX Approved
- **M.T.B.F Minimum 100,000 Hour**

2.1 Principles Of Operation

The Model 20/20F Radiation Flame Detector is an electronic device designed to sense the occurrence of fire and flames and subsequently activate an alarm or an extinguishing system directly or through a control circuit.

The UV-IR Radiation Flame Detector is a dual spectrum optical detector sensitive to two separate ranges of the radiation spectrum, both of which are present in fires. The detector monitors the protected volume, by measuring the radiation intensity in it, within two frequencies ranges of the electromagnetic spectrum, namely the Ultra-Violet (UV) and the Infra-Red (IR).

2.2 Sensing Elements

The IR sensor is sensitive to radiation over the range of 2.5-3.0 micron. The IR channel will register a detection signal, at the appropriate level, when the IR sensor is exposed to radiation in the appropriate frequency range, having an intermittent gleam pattern characteristic to flickering-fire, and a preset threshold and time duration are reached.

The UV sensor is sensitive to radiation over the range of 0.185-0.260 micron. The UV channel incorporates a special logic circuit that eliminates false alarms caused by solar radiation and other non-fire UV sources. Further more; the UV channel sensitivity is stabilized over the working temperature range.

2.3 Detection Levels

Simultaneous detection of radiation in both the UV and the IR channels having an intensity, which exceeds detector's preset Alarm level, will result in an Alarm signal.

Simultaneous detection of radiation in both the UV and the IR channels having an intensity which exceeds detector's preset Flash-Fire Detection level will result in an immediate Alarm signal, regardless of the detector mode setting selected.

Since the preset dual range and level of radiation, as well as the flickering pattern, are characteristic of real fire, all other radiation sources apart from actual fire will not be detected, thus avoiding false alarms.

2.4 Detector Structure

Figure 1 shows an outline drawing of the Flame Detector Assembly.

Figure 2 shows a schematic section of the internal Flame Detector, and describes its main components.

2.5 System Configuration

The Spectrex model 20/20F is a self-contained Optical Flame Detector that can function as a stand alone unit directly connected to external devices as alarm systems or automatic fire extinguishing systems. The same detector can form part of a more complex system where a plurality of detectors and other devices are integrated through a dedicated control unit.

2.6 Detector Type

The 20/20F is available in 4 models:

20/20F-C	Fast UV/IR Flame Detector in Aluminum Housing
20/20F-C-ST	Fast UV/IR Flame Detector in St.St. Housing
20/20FE-C	Fast UV/IR Flame Detector "de" Version in Aluminum Housing
20/20FE-C-ST	Fast UV/IR Flame Detector "de" Version in St.St. Housing

2.7 Product Marking

The 20/20F Optical Flame Detector is certified to:

ATEX EXII 2G per

SIRA 00ATEX 1161, EExd IIB + H₂ T5 Amb. Temp. = -40°C to +70°C and

SIRA 00ATEX 1165, EExde IIB + H₂ T5 Amb. Temp. = -40°C to +70°C

The detectors suitable for use in hazardous zones 1 and 2 where groups IIB + H₂ gases and vapor are present.

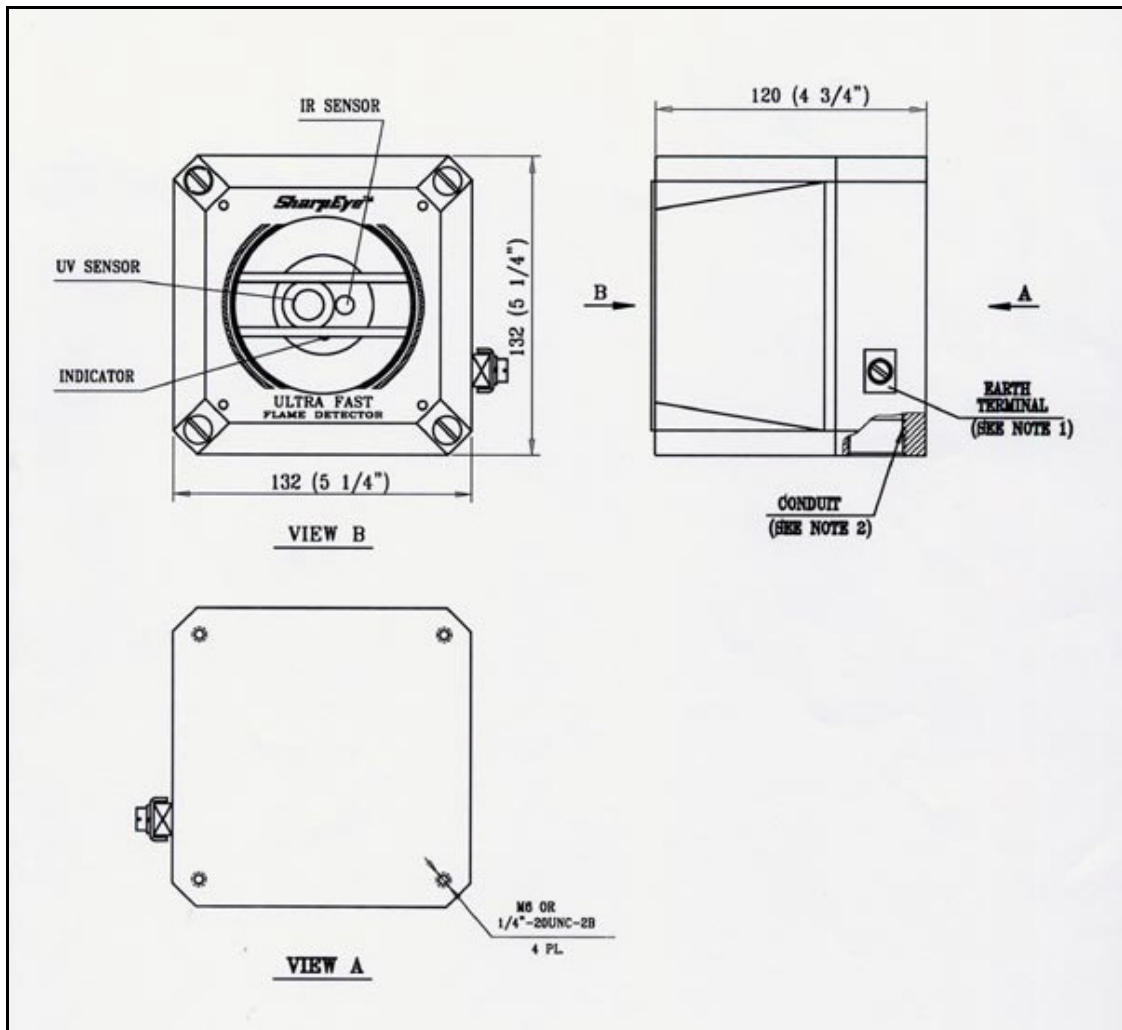

Figure 1. Flame Detector Assembly - Outline Drawing

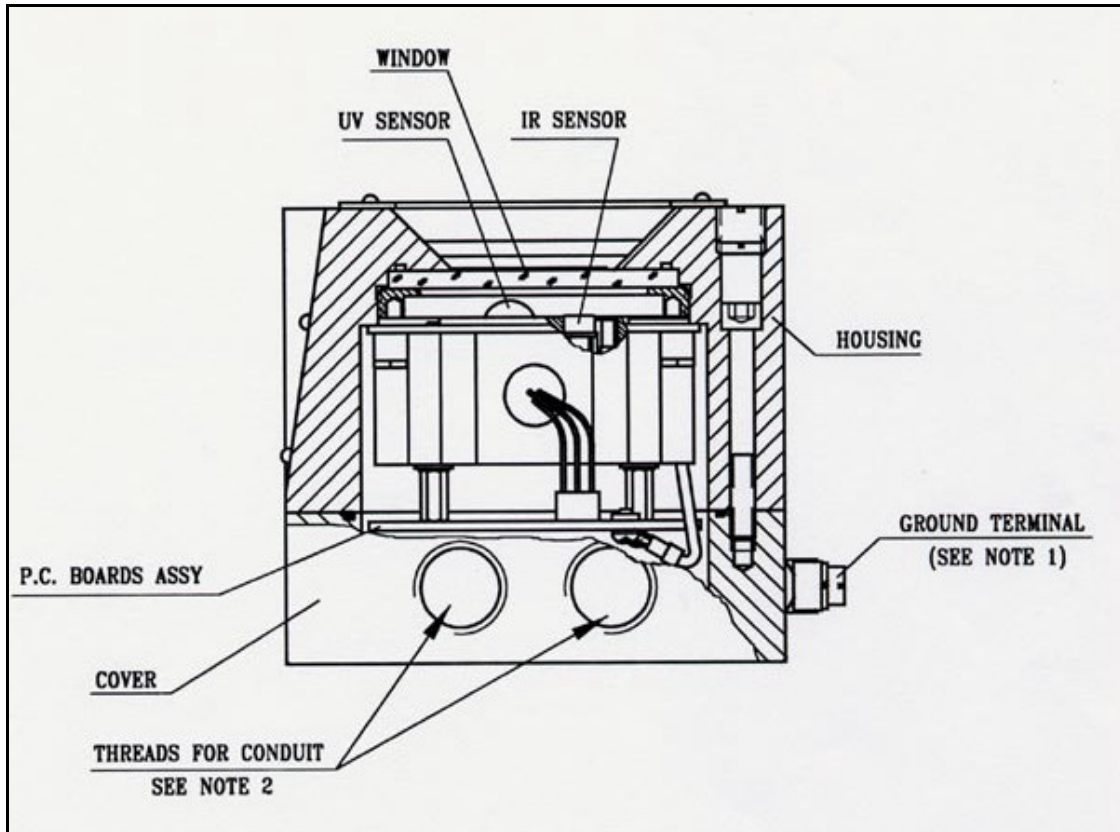

Figure 2. Flame Detector Assembly - Schematic Section

- Note 1: This figure describes the Detector, which includes Ground Terminal for ATEX installation. For FM installation, device includes 1/4" thread for external grounding screw mounting.
- Note 2: Conduit/cable entries - standard size is 3/4"-14NPT or M25 as specified at time of order

3. Performance

3.1 Detection Sensitivity

Detection sensitivity is the maximum distance at which the detector will reliably detect a specific size of fire & typical type of fuel (standard fire).

Standard Fire:

Standard fire is defined as a 1ft x 1ft (0.3m x 0.3m) Gasoline pan fire with max. wind speed of 6.5ft/sec (2m/sec).

Detection Range:

20 ft (6 m) from 1ft x 1ft (0.3m x 0.3m) standard gasoline pan fire.

Sensitivity Ranges:

For some typical ambient conditions the Zeta parameter as defined in NFPA 72 for the detector is 0.01 (1/meter).

Note:

Zeta parameters may vary significantly with changes in temp, air pressure, humidity, visibility conditions, etc.

Response Time:

Max. 5 msec. for Ö 5" (Ö12 cm) gasoline pan fire at a distance of 1 ft (30cm).
Typical 3 sec. for 1ft x 1ft (0.3m x 0.3m) gasoline standard fire at 20 ft (6 m).

Other Fuels:

The Detector will react to other fuels in standard fire conditions at maximum response time of 3 seconds.

The sensitivity range to other fuels varies according to the fuel type. Table 1 below provides the sensitivity to other fuels relative to (as a percentage of) the sensitivity to a standard gasoline fire source.

Table 1. Response Sensitivity Ranges

Type of Fuel	% of Max. Distance at Each Sensitivity Range
Gasoline	100%
N-Heptane	100%
Alcohol 95%	25%
JP4	75%
Kerosene	75%
Diesel Fuel	50%

Table 2: Response to Pyrotechnic Material

Material	Description	Time to Detection
RS41	Incendiary composition	2-3 msec
M206	IR Flare composition	3-4 msec
M14	Propellant	12-41 msec

3.2 Cone Of Vision

Horizontal: 90°

Vertical: 70°

Figure 3 illustrates the relative range as a function of the incidence angle.

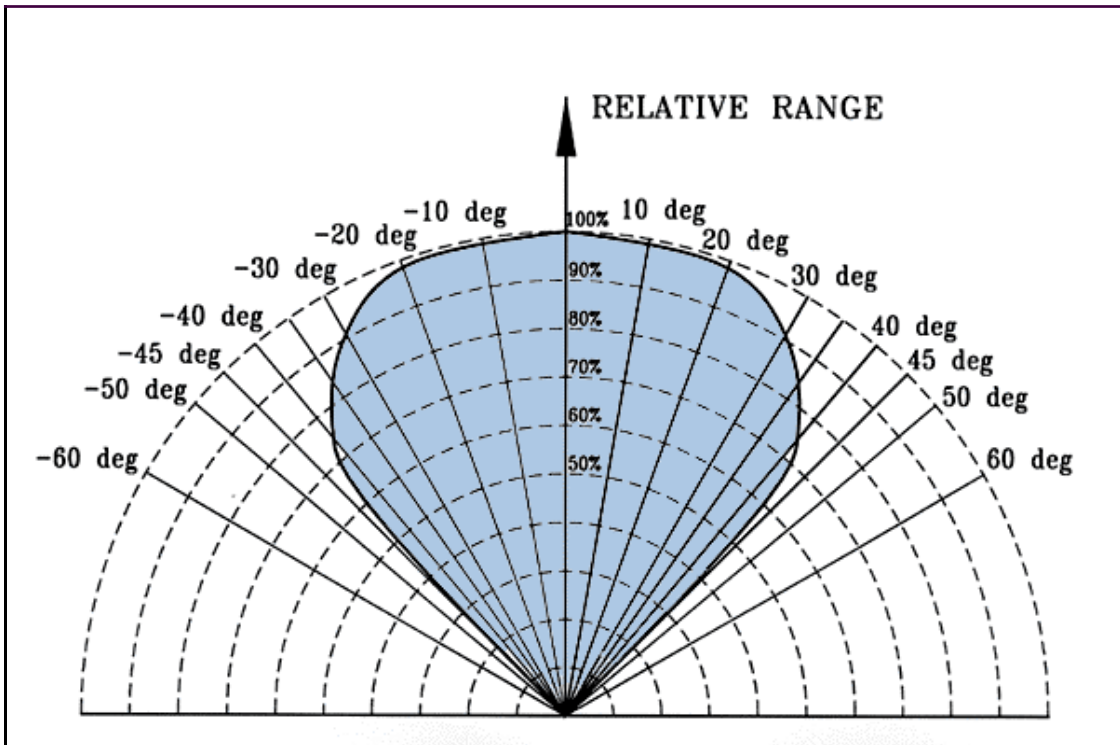

Figure 3. Horizontal and Vertical Fields of View

3.3 False Alarms

The detector does not provide an alarm or a warning signal as a reaction to the radiation sources specified at Table 3 below.

Notes:

IAD = Immune at any distance.

All sources are chopped from 0 to 20 Hz.

* Will be the same immunity distance as indicated when not chopped.

Table 3. Immunity to False Alarm Faults

Radiation Source	Immunity Distance ft. (cm)
Sunlight	IAD
Indirect or reflected sunlight	IAD
Vehicle headlights (low beam) conforming to MS53023-1	IAD
Vehicle Infrared light-MS 53024-1 or normal 50 watts	IAD
Incandescent frosted glass light, 100W	IAD
Flash light	IAD
Fluorescent light 40W (or two 20W)	IAD
Red dome light conforming to M251073-1 MS 51073-1	IAD
Radiation heater, 1500W	IAD
Radiation heater, 1000W with fan	IAD
Lit cigar or cigarette	IAD
Match, wood, stick including flare up	0.5ft (15cm)

4. Operation

4.1 Visual Indications

One Red LED is located in the detector's front window. In Alarm condition, the LED is continuously 'on'.

4.2 Output Signals

The detector includes the following control outputs:

- Alarm Relay
- Fault Relay
- Voltage Level Output

5. Technical Specifications

5.1 Electrical Specifications

a. Operating Voltage: 18-32 VDC

b. Power Consumption:

Max. 70mA - Stand-by

Max. 130mA - Alarm

c. Electric input protection:

The input circuit is protected against voltage reversed polarity voltage transients, surges and spikes according to MIL-STD-1275A.

d. Electrical Interface:

Terminals	Function
1	POWER SUPPLY IN (+)
2	RTN
3	OUTPUT SIG NAL
4	ALARM RELAY (NO)
5	ALARM RELAY (C)
6	FAULT RELAY (NO)
7	FAULT RELAY (C)

The FAULT relay will be normally energized closed normal operation of the detector. The contact will be open at FAULT condition or low voltage.

e. Electrical Outputs:**Table 4. Dry Contacts Relays Ratings**

Relay Name	Type	Normal position	Maximum Ratings
Alarm	SPDT	N.O.	5A at 30VDC or 250 VAC
Fault	SPST	N.C.	5A at 30VDC or 250 VAC

5.2 Mechanical Specifications**a. Enclosure:**

Aluminum: Chromate coating with Epoxy enamel finish
or
Stainless Steel 316: Electrochemical passivation coating

b. Explosion Proof

ATEX	Ex II 2G SIRA 00ATEX 1160, 1162
	EExd IIB + H ₂ T5 Temp. -40°F (-40°C) to 160°F (70°C) T4 Temp: -40°F (-40°C) to 185°F (85°C) per EN 50014 & EN 50018
	EExde IIB + H ₂ T5 Temp. -40°F (-40°C) to 160°F (70°C) per EN 50014, 50018 & 50019 (see Appendix C)
FM (designed to meet)	Class I Div. 1 Groups B, C and D; Class II Div. 1 Groups E, F and G.

c. Electrical Modules: Conformal coating.**d. Electrical connection:**

Either: Two 3/4" - 14NPT conduits.
or: Two M25 x 1.5 cable entries

e. Dimensions:

Detector: 5.2 x 5.2 x 4.7in (132 x 132 x 120 mm)

f. Weight:

Alum. enclosure	8.1 lb. (3.7kg)
St.St. enclosure	14.3 lb (6.5kg)

5.3 Environmental Specifications

a. High Temperature:

Design to MIL -STD-810C, method 501.1 procedure II
Operating temperature: +70 °C (+160 °F)
Storage temperature: +85 °C (+185 °F)

b. Low Temperature:

Design to MIL -STD-810C, method 502.1, procedure I
Operating temperature: -40 °C (-40 °F)
Storage temperature: -55 °C (-65 °F)

c. Humidity:

Designed to meet MIL -STD-810C, method 507.1, procedure IV
Relative humidity of up to 95% for the operational temperature range.

d. Salt and Fog:

Designed to meet MIL -STD-810C, method 509.1 procedure I.
Exposure to a 5% salt solution for 48 hours

e. Water and Dust:

IP66 & IP67 per EN 60529
NEMA 250 Type 6P

f. Shock and Vibration:

Vibration: Designed to meet MIL -STD-810C method 514.2, procedure 1.
Mechanical Shock: Designed to meet MIL -STD-810C method 516.1, procedure 1.

g. Electromagnetic Compatibility (EMC):

The detector is design and approved according to the following EMC requirements:

Electrostatic Discharge (ESD):	IEC801-2: 1984.
Conducted emission:	EN55022, Class A.
Radiated emission:	EN55022, Class A.
Radiated immunity:	IEC801-3: 1984.
EFT/B:	IEC801-4: 1988.

6. Installation Instructions

6.1 Introduction

This chapter does not attempt to cover all of the standard practices and codes of installation. Rather, it emphasizes specific points of consideration and provides some general rules for qualified personnel. Special safety precautions are stressed wherever applicable.

6.2 General Considerations

Very Important

The detector should be aimed toward the center of the detection zone and have a completely unobstructed view of the protected area.

- Whenever possible, the detector face should be tilted down at a slight angle to prevent the accumulation of dust and dirt.
- Do not start an installation unless all conceivable considerations regarding detector locations have been taken into account.
- To ensure optimal performance and an efficient installation, the following guidelines should be considered.

a. Spacing and Location

The number of detectors and their locations in the protected area are affected by the following:

- Size of the protected area.
- Sensitivity of the detectors.
- Obstructed lines of sight.
- Cone of view of the detectors.

b. Environment

Dust, snow, rain and oil can reduce the detector's sensitivity and require more maintenance activities.

6.3 Preparations For Installation

Installation should comply with regulations (e.g. NFPA 72E), as applicable to flame detectors.

The detectors can be installed with the use of general-purpose common tools and equipment.

- 1 Verify the appropriate Purchase Order. Record the part number and Serial number of the detectors and the installation date in the appropriate Log-book.
- 2 Open the container package prior to detector installation and visually inspect the detector.
- 3 Verify that all components required for the detector installation are readily available before commencing the installation. In case that the installation is not completed in a single session, secure and seal detectors and conduits.
- 4 For wiring, use color-coded conductors or suitable wire markings or labels. Wire diameter between 12 to 20 AWG (3.0 to 0.5 mm²) may be used for site wiring. The selection of wire gauge should be based on the number of detectors used on the same line and the distance from the control unit, in compliance with specifications (see Appendix A)

6.4 Conduit Installation

- 1 To avoid water condensation in the detector, it should be installed with the conduits facing downward, and should include drain holes.
- 2 When using the optional swivel mount, use flexible conduits for the last portion connecting to the detector.
- 3 When pulling the cables through the conduits, ensure that they are not tangled or stressed. Extend the cables about 12 in. (30 cm) beyond the detector location to accommodate wiring after installation.
- 4 After the conductor cables have been pulled through the conduits, perform a continuity test.

6.5 Detector Mounting

The detector may be mounted on a simple fabricated bracket, or preferably the optional Spectrex Swivel Mount, Model No. 20/20-003. The Swivel Mount enables the detector to be rotated up to 40 degrees in all directions.

6.5.1 Swivel Mount Kit

Table 5: Mounting according to US Version

Item	QTY	Type /Model	Location
Swivel Mount	1	20/20-003	
Screw	4	1/4" -20UNC	Detector - Holding plate
1/4" Spring Washer	4	1/4"	Detector - Holding plate

Table 6: Mounting according to EU Version

Item	QTY	Type /Model	Location
Swivel Mount	1	20/20-003-1	
Screw	4	M6 x 1P	Detector - Holding plate
Spring Washer	4	M6	Detector - Holding plate

6.5.2 Swivel installation (Figure 4a and 4b)

- 1 Place the swivel mount (Item 6, Fig. 4a) in its designated location and secure it with four (4) M6 or 1/4" screws, placed 3.0 in. (76.2 mm.) apart on swivel mount plate (Item 6, Fig. 4b).

Note: Skip this step if the Swivel Mount is already installed. Also detector removal for maintenance purpose does not require Swivel Mount removal.

- 2 Unpack the detector carefully
- 3 Place the detector with its conduit inlets pointing down on the holding plate of the Swivel Mount (Item 3, Fig 4b). Secure the detector to the Swivel Mount by four (4) 1/4"-20UNC screws or M6 x 1P (Item 5, Fig 4a) with 1/4" (M6) spring washers enclosed with the Swivel Mount Kit. Use 3/16 Hex Key for 1/4" screws or No. 5 Hex Key for M6 screws.
- 4 Tighten the three locking 3/8"-24UNF screws (item 4, Fig 4b) of the swivel mount ring until the friction in the ball joint holds the detector in its position, maintaining the ability to be moved by hand-applied force (Use 3/16" HEX KEY).
- 5 Point the detector towards the protected area and make certain that the view of the area is not obstructed. Secure the detector in that position by tightening the locking screws of the swivel mount ring.

The detector is now correctly located and aligned, and ready for connecting to the system.

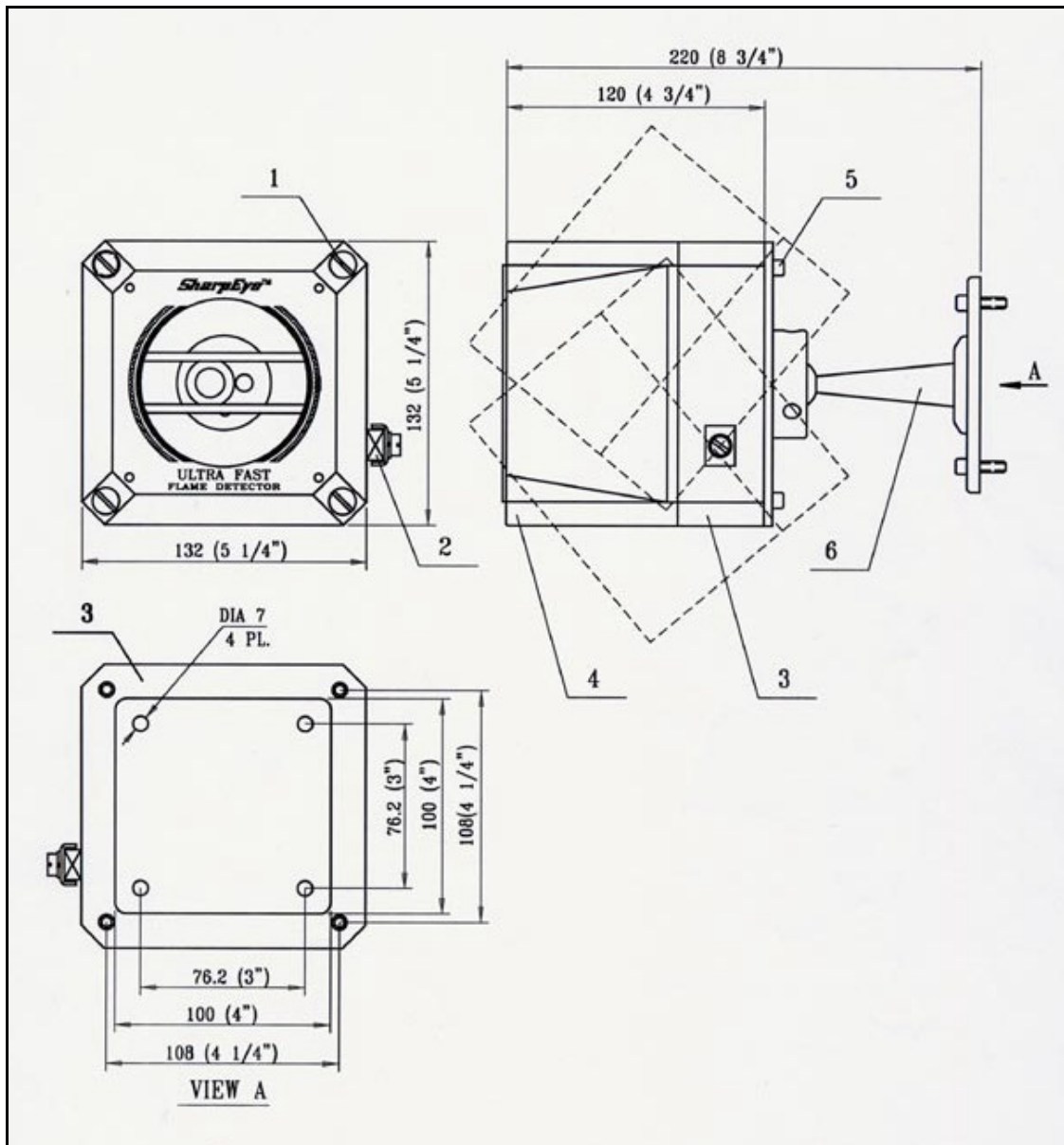

Description	
1	Protective Set Screws
2	Ground Terminal (for ATEX) or Ground Thread (for FM)
3	Back Cover
4	Housing
5	Detector Mounting Screws
6	Swivel Mount

Figure 4.a. UV/IR Detector and Swivel Mount Assembly

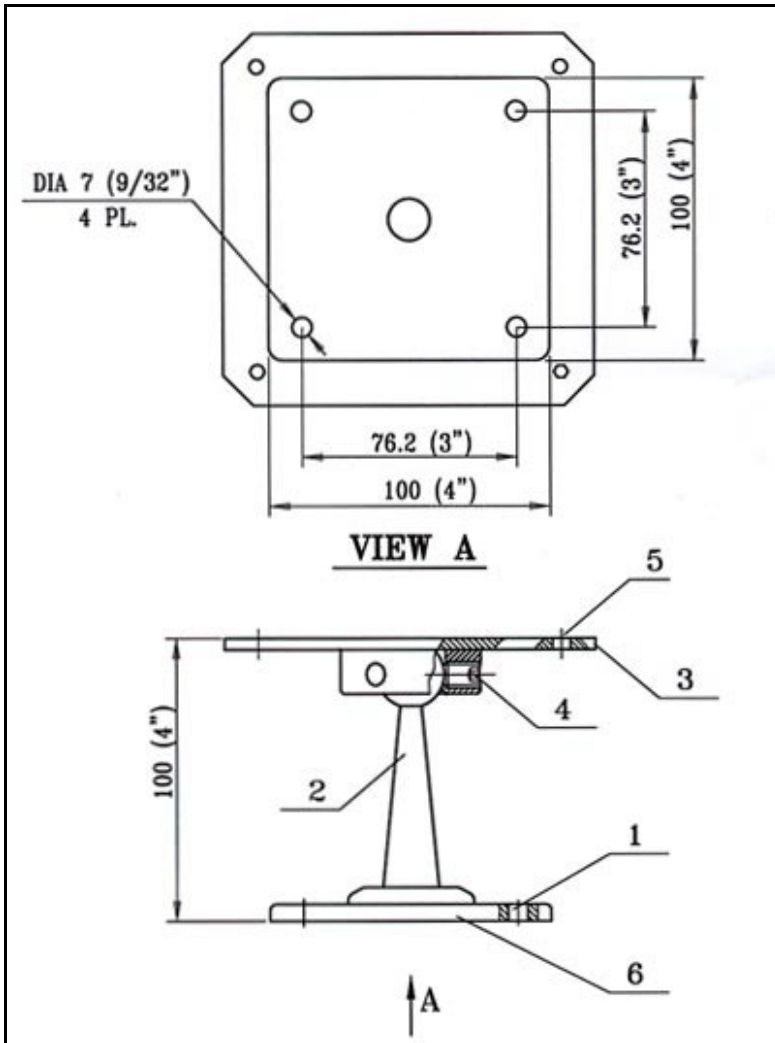

Description	
1	Swivel Mount Screw Hole
2	Swivel Mount
3	Holding Plate
4	Locking Screws
5	Detector Mounting Screws
6	Swivel Mount Plate

Figure 4.b. Swivel Mount Assembly

6.6 Wiring (Refer to Fig. 5)

- 1 Disconnect power.
- 2 Remove the four protective set-screws (Fig 4a, item 1) from detector front.
- 3 Release the four socket-head screws that secure the detector housing (Item 1) to its back cover (Item 4) using No. 5 Hex Key for M6 screw. Hold the housing during the removal of the screws. With the screws removed, pull the detector housing from its cover. The terminal board (Item 5) inside the detector cover is now revealed.
- 4 Remove the protective plug mounted on the detector conduit inlet (Item 6). Pull the wires through the detector cover (Item 4). Use a 3/4"-14NPT or M25 x 1.5P explosion-proof conduit/cable gland connection.
- 5 Connect the wires to the required terminals (Item 6) according to the wiring diagram. See section 6.7 and figures 6.
- 6 Connect a Grounding Cable to the Ground Terminal (Item 2) outside the detector cover (Item 4).

The detector must be well grounded to *Earth Ground* for proper operation.

- 7 Verify the wiring. Improper wiring may damage the detector.
- 8 Check the wires for secure mechanical connection and press them neatly against the Terminal Board (Item 6) to prevent them from interfering while closing the detector's housing.

6.7 Terminal Wiring (Figure 6)

The detector contains a terminal board labeled 1 to 7.

The following describes the function of each electrical terminal of the detectors.

Power Supply: (Terminals 1, 2)

Input power is supplied to terminal No. 1.

The RETURN is connected to terminal No.2.

Manual Bit Activation: (Terminal 3)

Terminal No. 3 is used for the manual BIT activation. The manual BIT is initiated by a momentary connection of Terminal No. 3 to the power supply return line.

Alarm Relay: (Terminals 4, 5)

The Alarm output is a change - over contact relay (SPDT)

Terminal No. 4 is the NO relay contact

Terminal No. 5 is the COMMON relate contact

Fault Relay: (Terminals 6, 7)

The Fault output in NC SPST contact at terminals no. 6 and 7. The contacts are closed when the detector is in its normal operational condition

Terminal No. 6 is the NO relay contact.

Terminal No. 7 is the common relay contact.

Note

To protect the dry contacts from voltage surges when connected to reactive loads (electric motors, sirens, etc.), connect an appropriate varistor over these contacts.

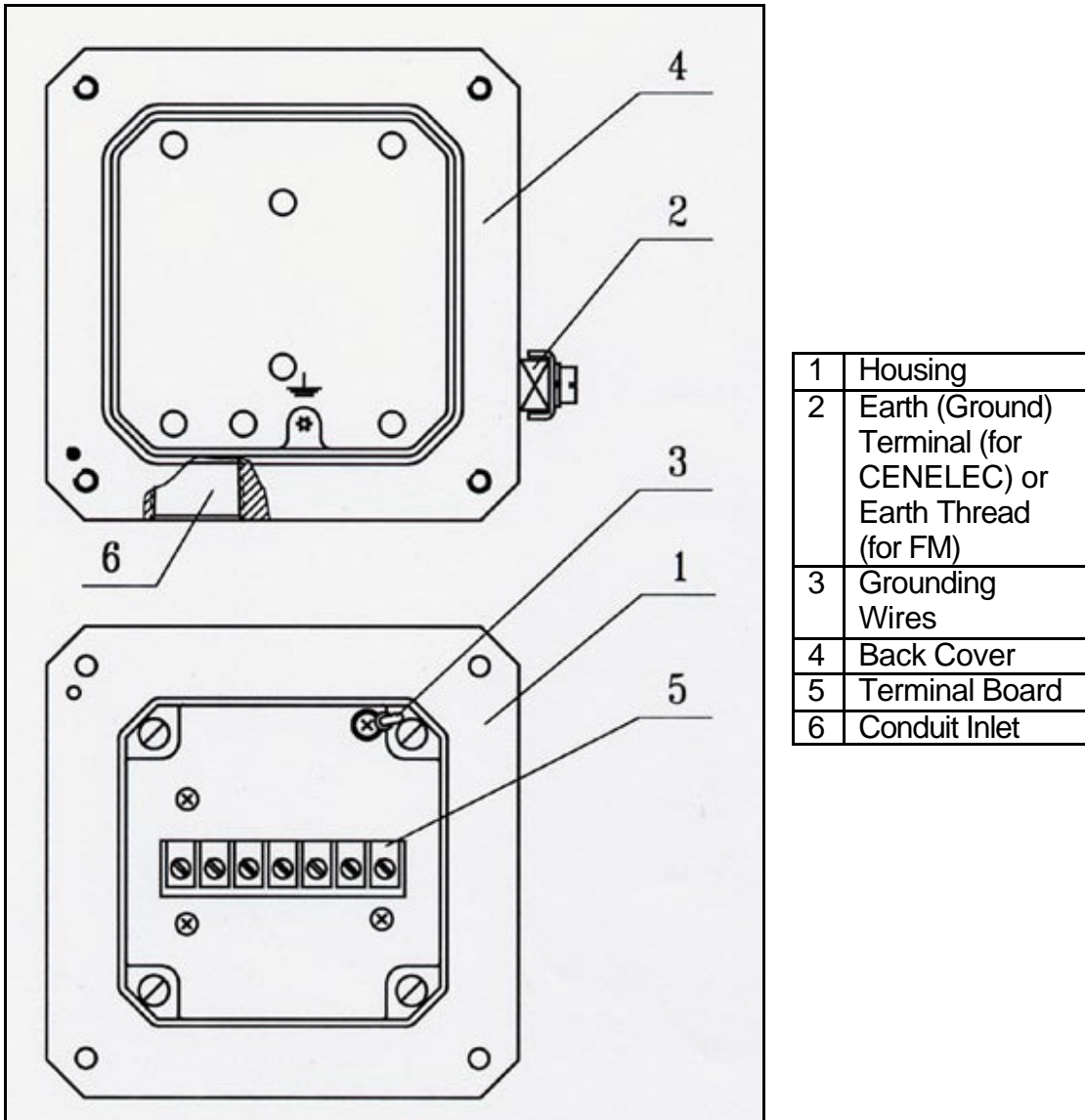

Figure 5. UV /IR Flame Detector with Cover Removed

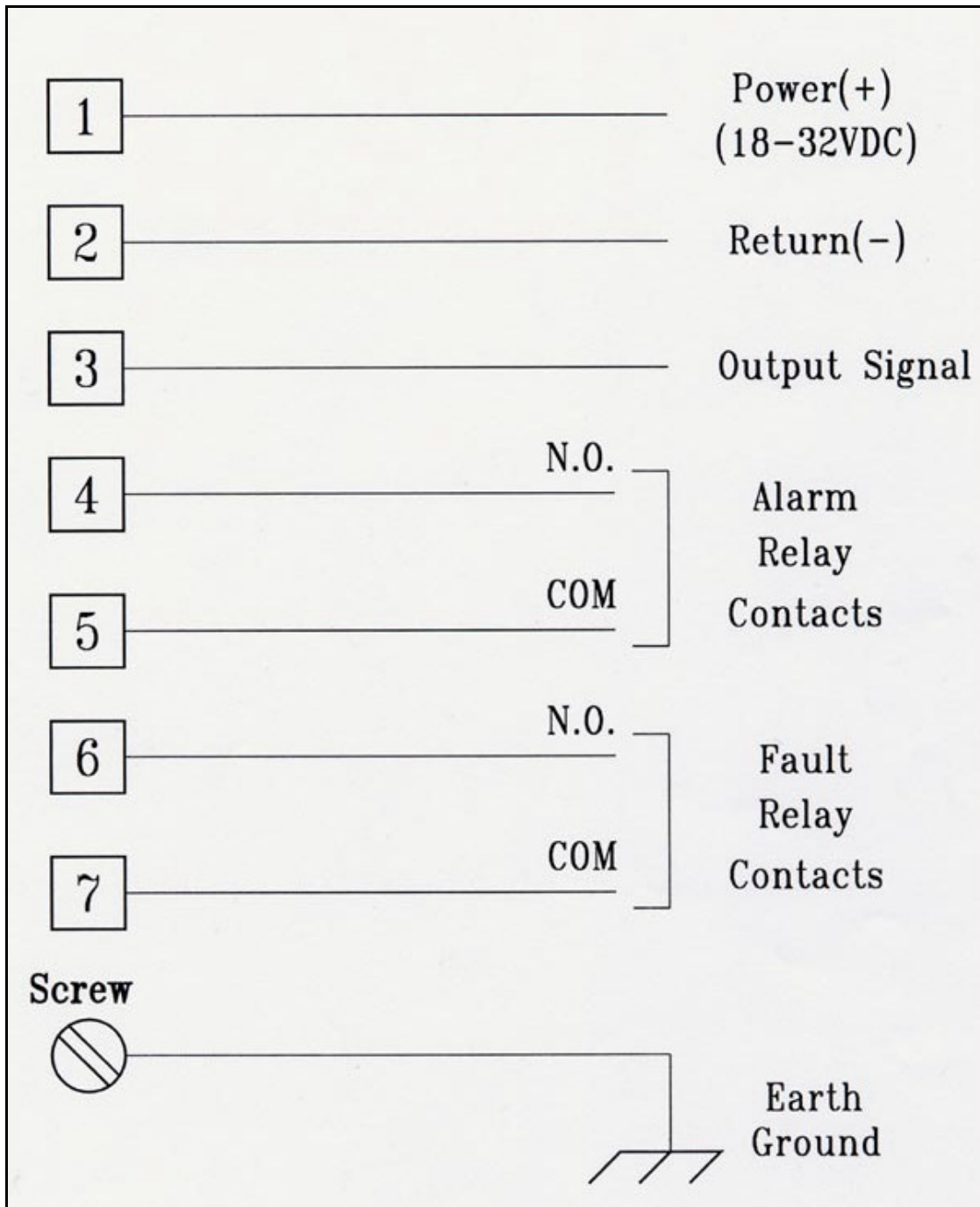

Figure 6. Flame Detector Assembly - Wiring Diagram

7. Operating Instructions

7.1 Scope

The following instructions are designed to obtain optimal performance from the detector over its life-cycle.

7.2 Power-Up

- 1 Apply power and wait up to 10 seconds; verify that the FAULT Relay closed contact (short between Terminal 6 and 7)
- 2 Wiring inspection. If a short-circuit or line discontinuity exists, indications will appear on the control unit display panel. Review your wiring.
- 3 The detector goes into its FAULT state when supply voltage drops under 16.5V. The detector status goes back to NORMAL when the supply voltage is above 17.5V.
- 4 If the outputs are different from the description in step 3, see section 8.6 for troubleshooting.

The Flame Detector is now ready for Functional Testing.

7.3 Testing With Fire Simulator (See Appendix D)

This test is producing to simulate an exposure of the detector to a real fire condition. The detector is exposed to the radiation in the specified detection level. As a result, the detector must generate a Fire Alarm signal

Important Note!

If the detector is exposed to a fire simulator the Alarm Relay will be activated during the simulation. Therefore, automatic extinguishing systems or any external devices that may be activated during this process must be disconnected.

- 1 Apply power to the system and wait up to 10 seconds for turning of the detector to normal state. The FAULT Relay contact should be closed.
- 2 Aim the Spectrex Fire Simulator Model 20/20-311 at the target point of the detector (see Fig. 11), in a way that the radiation emitted by it is facing directly towards the detector (See Appendix D.)
- 3 Press the operation button once. Verify that
 - The LED should be on and remain so for a few seconds.
 - Terminal 3 should apply 4- 4.7 voltage for a few seconds.
 - The Alarm Relay will close contacts for a few seconds.After this period of time
 - The LED should return to off
 - The output at Terminal 3 should return to 0
 - The Alarm Relay should open contacts (4, 5)

7.4 Safety Precautions

After powering-up, the detector requires minimal attention in order to function properly, but the following should be noted

- 1 Follow the instructions in the manual and refer to the drawings and specifications issued by the manufacturer.
- 2 Do not expose the detector to radiation of any kind unless required for testing purposes.
- 3 Do not open the detector housing, while power is supplied.
- 4 Do not touch internal parts other than the two functional switches. Interference with internal circuits may impair detector performance and will invalidate manufacturers warranty.
- 5 Disconnect external devices, such as automatic extinguishing systems before carrying our any maintenance task.

8. Maintenance Instructions

8.1 Scope

This chapter deals with preventive maintenance, describes possible faults in detector operation and indicates corrective measures. Ignoring these instructions may cause problems with the detector and any invalidate the warranty.

Whenever a unit requires service, please contact the manufacturer or its authorized distributor for assistance.

8.2 Maintenance Tools and Personnel

The detector's maintenance requires ordinary tools and qualified personnel, who should be familiar with local codes and practices

8.3 Preventive Maintenance Procedures

The detector must be kept as clean as possible. The viewing window and the reflector of the model 20/20F Flame Detector must be cleaned on a periodic basis. The frequency of cleaning operations depends upon the environmental conditions and specific applications. The fire detection system designer will give his recommendations. Use of the optional AIR SHIELD Model 20/20-930 is highly recommended and will help to keep the window clean and prevent dirt from accumulating on the window.

- 1 Disconnect power to the detector before proceeding with any maintenance.
- 2 To clean the detector-viewing window and reflector use water and detergent then rinse with clean water.
- 3 Where dust, dirt or moisture accumulates on the window, first clean with a small soft brush under the window guard, then clean with a soft optical cloth and detergent and finally rinse with clean water. Do not attempt to open the window guard since it should not be removed.

8.4 Periodic Maintenance Procedures

In addition to preventive cleaning and maintenance, the detector should be functionally tested every six months. The test should also be carried out for any reason the detector has been opened.

8.4.1 Power Up Procedure

Perform Power-Up procedure every time power is restored to the system. Follow the instructions in section 7.2.

8.4.2 Functional Test Procedure

Perform a functional test of the detector as described in section 7.3.

8.5 Maintenance Records

It is recommended to record maintenance operations performed on a detector in a System Log Book. The record should include information, which identifies the unit, installation date, contractor, and entries for every maintenance operation performed including the description of the operation, date and personnel ID. If a unit is sent to the manufacturer or distributor for service, a copy of the Maintenance records should accompany it.

8.6 Troubleshooting

8.6.1 Fault Indication

The following subsections describe possible faults and suggestion for immediate solutions.

- 1 Check power supply for correct voltage, polarity and wiring.
- 2 Disconnect the power supply from the system and check the detectors' internal wiring.
- 3 Re-connect powers supply and wait approximately 10 seconds. Repeat the test. If the FAULT relay is still at open contacts, the unit is faulty and must be removed and sent in for repair.

8.6.2 False Alarm or Warning Indication

Check detector window. If necessary, clean the window as indicated in Section 8.3.

Appendix A - Wire Selection Tables

GENERAL INSTRUCTION FOR ELECTRICAL WIRING:

1. Refer to Table 7 to determine the required wire gauge for general wiring, such as relay wiring. Calculate the permitted voltage fall with respect to loads current, wire gauge, length of wires.
2. Refer to Table 8 to select wire gauge for detectors power supply wires. DO NOT connect any device or load to detectors supply inputs.

Table 7. Maximum DC resistance at 68°F for copper wire

AWG	mm ²	Ohm per 100 ft.	Ohm per 100 meter
26	0.12 - 0.15	4.32	14.15
24	0.16 - 0.24	3.42	11.22
22	0.30 - 0.38	1.71	5.60
20	0.51 - 0.61	1.07	3.50
18	0.81 - 0.96	0.67	2.20
16	1.22 - 1.43	0.43	1.40
14	1.94 - 2.28	0.27	0.88
12	3.09 - 3.40	0.17	0.55
10	4.56 - 6.64	0.11	0.35

Wiring Gauge

- 1 Select "No. of detectors" connected on one circuit.
- 2 Select "wiring length" per your installation requirements.
- 3 Refer to "Power Supply Range" for voltage extreme applied.

Table 8. Wiring length in feet (meter)

No. of Detectors	Recommended Wire Diameter					Power Supply Range (VDC)
24	18	16	14	-	-	22-32
20	18	16	14	-	-	22-32
16	20	18	16	14	-	22-32
12	20	18	16	14	-	20-32
8	20	18	16	14	-	20-32
4 and less	20	18	16	16	14	20-32
Feet (meter)	164 (50)	328 (100)	492 (150)	656 (200)	820 (250)	
	Max. Length from Power Supply to Last Detector					

Appendix B. Typical Wiring Configurations

Wiring for Four Wire Controllers:

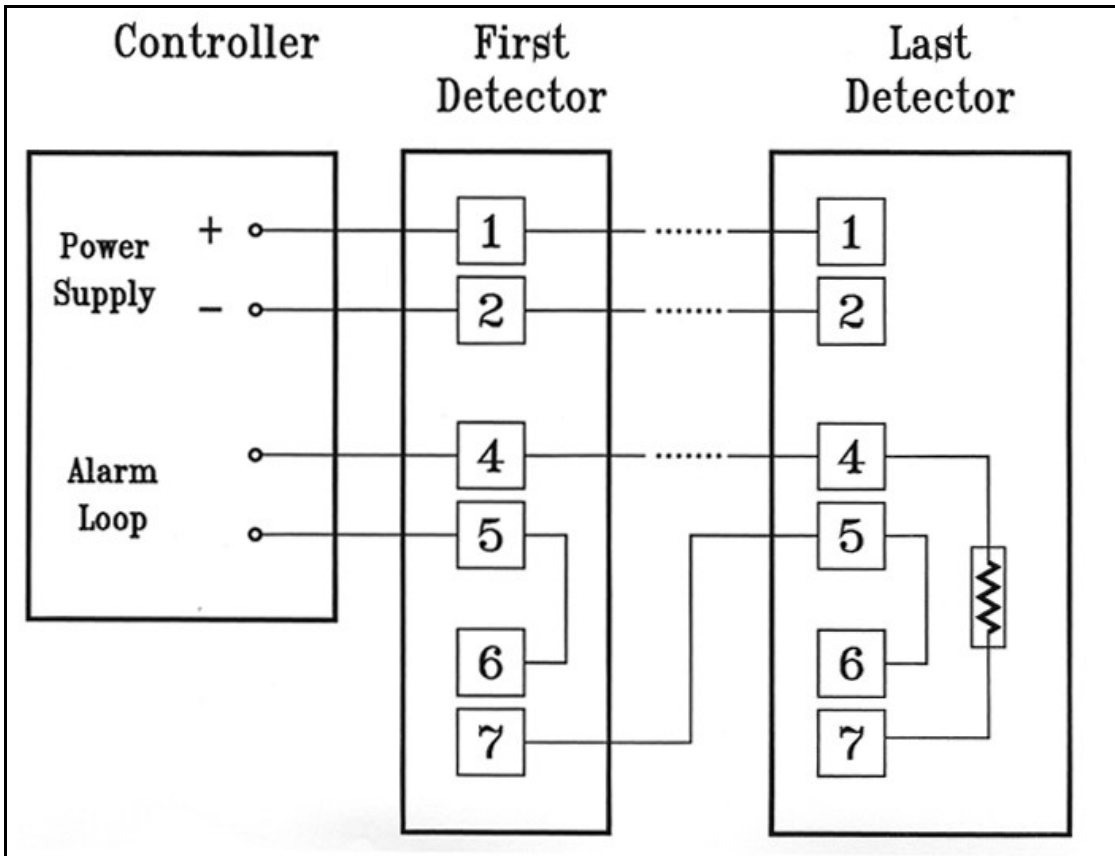

Figure 7. Typical Wiring Diagram for Four-Wire Controller

Appendix C. Mounting the “EExde approved” version

The EExde approved version provides an additional EExe terminal box attached below the EExd detector and therefore allows easier access in hazardous areas (see fig. 10). The unit is prewired to the terminals in the additional EExe terminal section ready for field wiring connections

1. Detector Mounting

The detector may be mounted on a simple fabricated bracket, or preferably the optional Swivel Mount, Model 20/20-003. The Swivel Mount enables the detector to be rotated up to 40 degrees in all directions.

1.1 Swivel Mount Kit

Use the kit from the paragraph 6.5.1

1.2 Swivel installation

- 1 **Refer to Fig. 4b and Fig. 8** Place the swivel mount in its designated location and secure it with four (4) M6 or 1/4" screws, placed 76.2 mm. (3.0 in.) apart on the swivel mount plate (item 6, Fig 4b).

Note: Skip this step if the Swivel Mount is already installed. Also detector removal for maintenance purpose does not require Swivel Mount removal.

- 2 Unpack the detector.
- 3 Place the detector, with its cable inlets pointing down, on the holding plate of the swivel mount (Fig. 4a item 6). Secure the detector by four (4) M6 screws with M6 spring washers from the Swivel Mount Kit using the holes. You can use the thread on the modified cover (Fig. 8 item 1) marked either triangle symbol or square symbol. Use No. 5 Hex Key for M6 screws.
- 4 Tighten the three locking 3/8"-24UNF screws (Fig. 4b item 4) of the swivel mount ring until the friction in the ball joint holds the detector in its position. Yet, still permits it to be moved by hand-applied force (Use No.5 Hex Key).
- 5 Point the detector towards the protected area and make certain that the view of the area. Secure the detector in that position by tightening the locking screws (Fig.4b item 4) of the swivel mount ring.

The detector is now correctly located and aligned and ready for connecting to the system.

2. Wiring

Refer to Fig. 8.

- 1 Disconnect power.
- 2 Release the four (4) slotted-head screws (Item 3) that secure the chamber cover (Item 2). The chamber is now revealed.
- 3 Remove the protective plug mounted on the detector conduit inlet, pull the wires through the detector chamber (Item 7). Use M25x1.5 explosion-proof cable entry to assemble the cable to the detector.
- 4 Connect the wires to the required terminals (Item 4) according to the wiring diagram. See paragraph 2.1 and figures no. 11 and no. 12.
- 5 Connect the grounding wire to the ground screw outside the detector cover (Item 5).

The detector must be well grounded to *Earth Ground* for proper operation.

- 6 Verify the wiring. Improper wiring may damage the detector.
- 7 Check the wires for secure mechanical connection and press them neatly against the terminal to prevent them from interfering while closing the cover (Item 2).
- 8 Place and secure the cover chamber (Item 2) using four (4) slotted-head screws (Item 3).

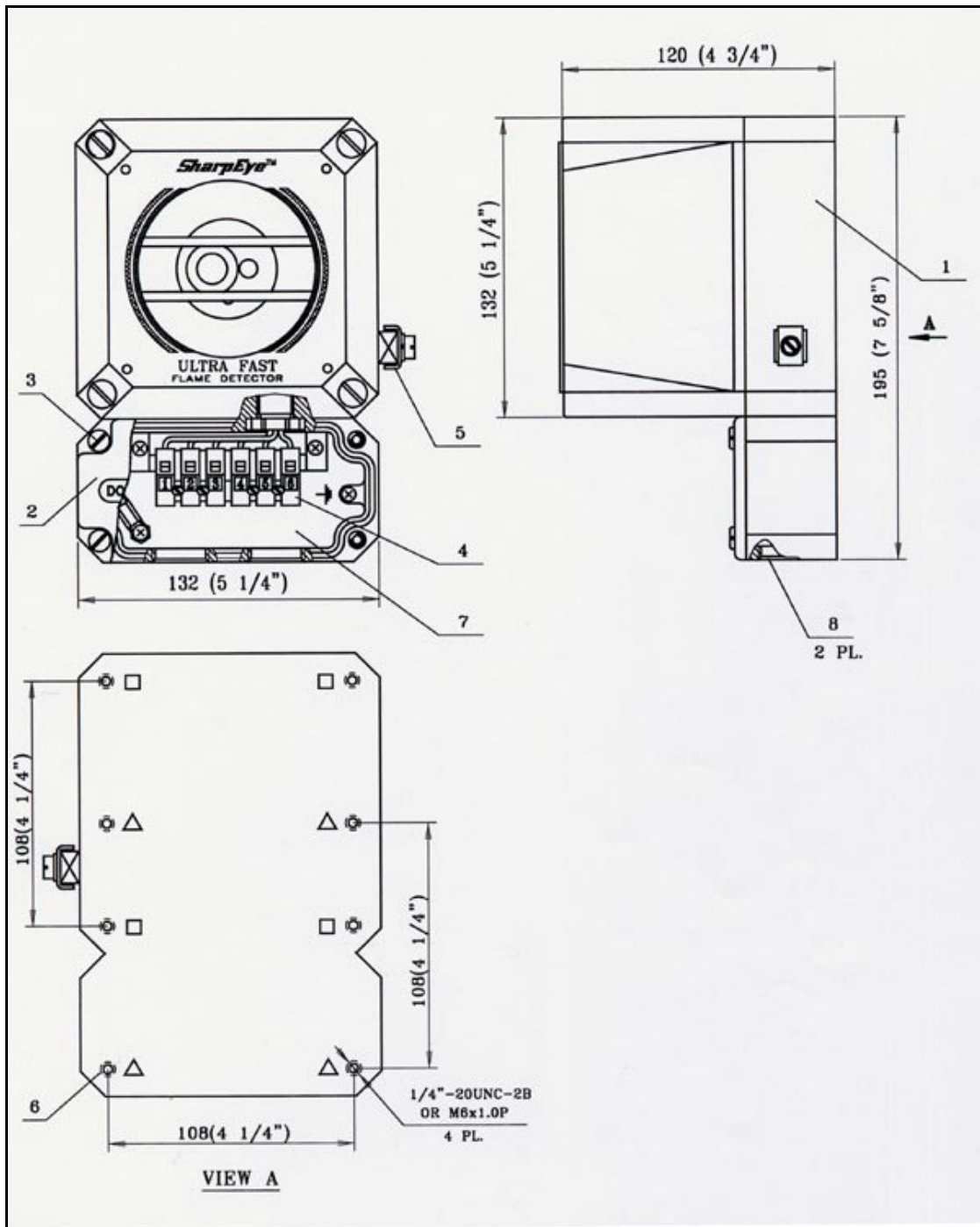

Description	
1	Modified Back Cover
2	Chamber Cover
3	Slotted Screw
4	Terminal Block
5	Ground Terminal
6	Mounting Thread
7	Chamber
8	Cable Inlet (M25 x 1.5)

Figure 8: Flame Detector Assembly - Wiring Diagram

2.1 Terminal Wiring

The detector contains a chamber consisting of a terminal block (Item 4). The terminal block is labeled 1 to 6. (**See Fig. No.9.**)

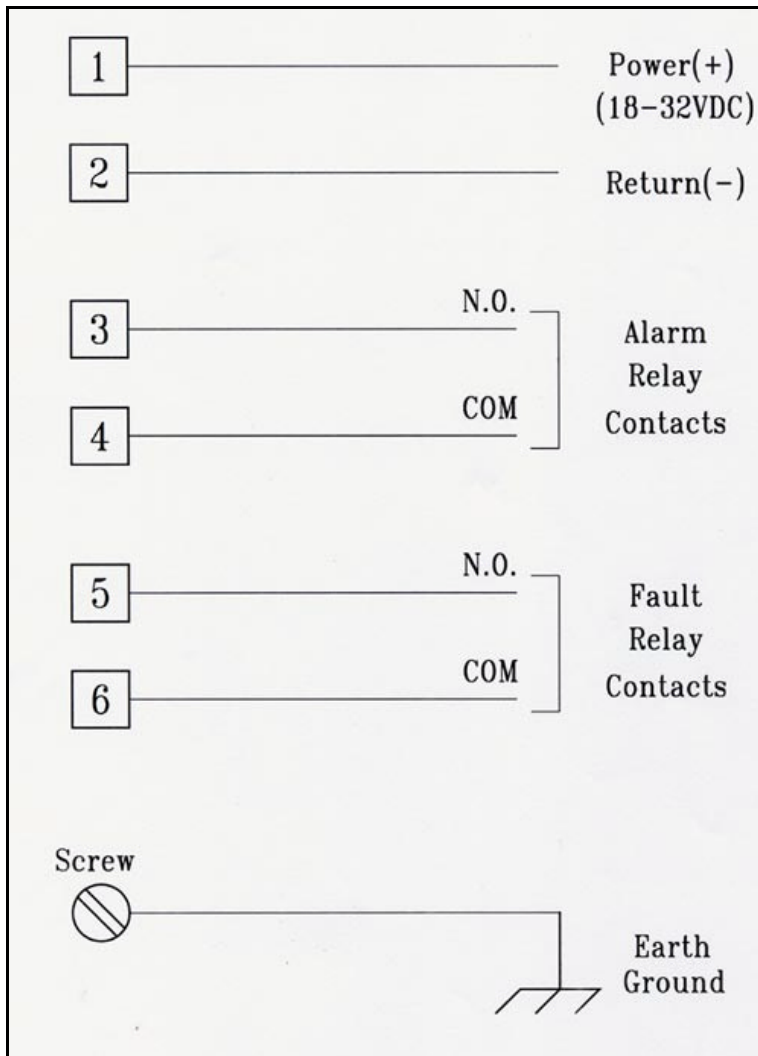

Power Supply

(Terminal Numbers 1, 2): Input power is supplied to Terminal No. 1. RETURN is connected to Terminal No. 2.

Alarm Relay (Terminal Numbers 3, 4):

The Alarm output is a NO. SPST contact at Terminal Numbers 3 and 4. The contacts are closed at Alarm Mode.

Fault Relay (Terminal Numbers 5, 6):

The Fault output is NC. SPST contact at Terminal Numbers 5 and 6. The contacts are open at Fault condition.

Figure 9: Flame Detector Assembly - Wiring Diagram
("de version")

Appendix D. Long Range UV/IR Fire Simulator

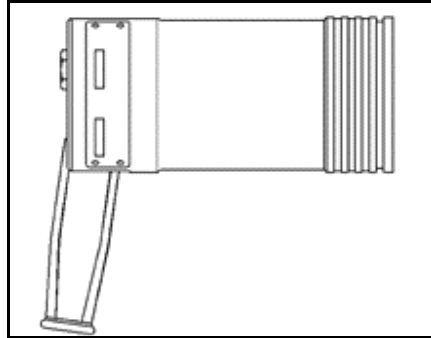

Figure 10: Fire Simulator

Product Description

The SharpEye UV/IR Long-Range Fire simulator 20/20-311 is designed specifically for use with the UV/IR or UV flame detectors. The Fire Simulator emits UV/IR radiation in a unique sequential pattern corresponding and recognizable by the detector as fire. This allows the detectors to be tested under real fire conditions without the associated risks of an open flame.

Unpacking

In addition to the delivery form, there should be the following contents:

- Fire Simulator with built in batteries
- Battery charger
- Storage case

Operating Instructions

Warning: Do not open the Fire Simulator to charge the batteries or for any other reason in a hazardous area.

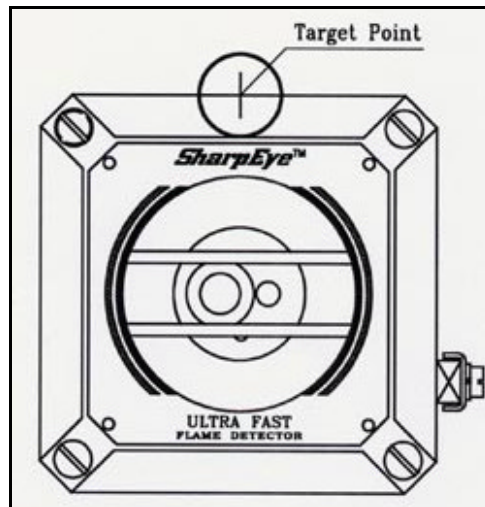

Figure 11: UV/IR Detector Target Point

Caution:

- 1 The following test will simulate a real fire condition and may activate the extinguishing system or other alarms. If this is not desired, disconnect them before the test and reconnect after the simulation.

Follow these instructions to simulate a fire:

- 1 Aim the Fire Simulator towards the detector's "Target Point" (see Fig. 14)
- 2 For testing, keep a distance of at least 20 inches (50cm) from the detector.
- 3 Press the operation button once. Fire simulation will last for 20 seconds. The detector will send an alarm signal.
- 4 For another fire simulation a 20 second time lapse is required between tests.
- 5 Make sure the optical window is clean and keep the Fire Simulator in the storage case when not in use.

Battery Charging

- 1 The Fire Simulator uses NiCad batteries as a rechargeable power source. When the batteries are fully charged it will operate for at least 60 uses without recharging.

An internal buzzer is sounded when the voltage from the batteries is lower than the required operational level.

- 2 Place the Fire Simulator into the storage case on a table in a safe area.
- 3 Turn the sealed plug (next to the operation button) counter clockwise with a suitable wrench.
- 4 Connect the battery charger.
- 5 Charge for a maximum of 14 hours.
- 6 Disconnect the charger.
- 7 Tighten the sealed plug clockwise.

Specifications

Mechanical		
Explosion Proof Enclosure: FM (designed to meet) Class I, Division 1 & 2 Groups B, C and D Class II, Division 1 & 2 Groups E, F, and G		
ATEX EX II2G NEMKO 02ATEX255 EExd IIB T5 50 C per En 50-014 & EN50-018		
Electrical		
Power: 8 VDC Max 6 x Rechargeable 1.2 VDC NiCd Batteries		
Current: 2.5A Avg.		
Charge: 400mA for 14 Hours		
Environmental		
Temperature Range: -4° F (-20° C) to 122° F (50° C)		
Vibration Protection: 1g (10-50hz)		
Water and Dust: IP 67 per EN 60529		
Physical		
Dimension: 11.5 x 10.1 x 3.9 in (292 x 258 x 100 mm)		
Weight: 7.5 lb. (3.4 Kg)		
Range*		
Model	Standard	Extended Range
20/20L	14.5 ft (4.5m)	29 ft (9 m)
20/20U	14.5 ft (4.5m)	29 ft (9 m)
20/20LB	14.5 ft (4.5m)	29 ft (9 m)
20/20UB	14.5 ft (4.5m)	29 ft (9 m)
20/20F	2.4 ft (0.75m)	-

* The minimum distance from the detector is 20 inches (50cm)

* At extreme temperatures 15% Max. Reduction

For additional details or assistance, please contact

218 Little Falls Road
Cedar Grove, NJ 07009, USA
Tel: +1 (973) 239-8398
Fax: +1 (973) 239-7614
Email: spectrex@spectrex-inc.com
Web-site: www.spectrex-inc.com

Your Local Authorized Distributor: