

Model 56 Advanced Dual-Input Analyzer

- **High resolution full-color screen** – easily viewed process measurements and on-screen data trend graphs
- **User help screens** – detailed instructions and troubleshooting in multiple languages
- **Data Logger and Event Logger** – Download process data and alarm conditions with time and date stamps via USB 2.0 data port
- **Control** – PID and time proportional capabilities. Also includes synchronized interval timers and four special application functions.
- **Digital Communications** – HART® and Profibus® DP communications with full features and functionality
- **Measurements** – pH, ORP, ISE, Resistivity/ Conductivity, % Concentration, Total Dissolved Solids, Total Chlorine, Free Chlorine, Monochloramine, Oxygen, Ozone, Turbidity, Pulse Flow, Temperature, and others via 4-20mA input from any device.

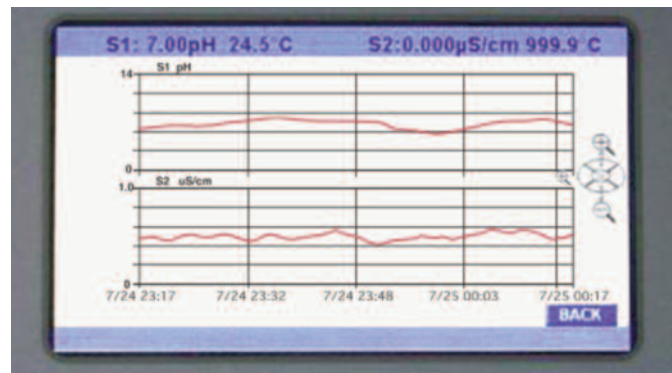

Quickly diagnose process conditions at a glance.

Features and Applications

The Model 56 advanced analyzer supports continuous measurement of analytical inputs from one or two sensors. The modular design allows signal input boards to be field replaced, making configuration changes easy. The high resolution full-color display gives unsurpassed visibility and functionality for analytical instrumentation.

Full Color Display: The high resolution full-color display allows easy at-a-glance viewing of process readings – indoors or outdoors. Six additional process variables or diagnostic parameters are always displayed for quick determination of process or sensor condition.

Menus: Intuitive screens for easy configuration and calibration. Quick Start and all menu screens are available in multiple local languages. Alpha-numeric keypad allows easy entries during configuration and calibration.

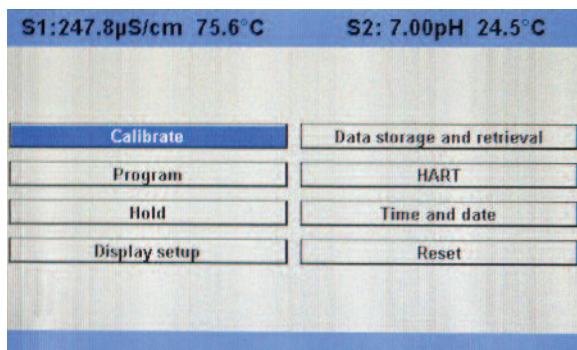

Quick Start Programming: Simplified Quick Start screens appear the first time the unit is powered. The instrument auto-recognizes each type of measurement board and prompts the user to configure each sensor loop in a few quick steps for immediate live readings.

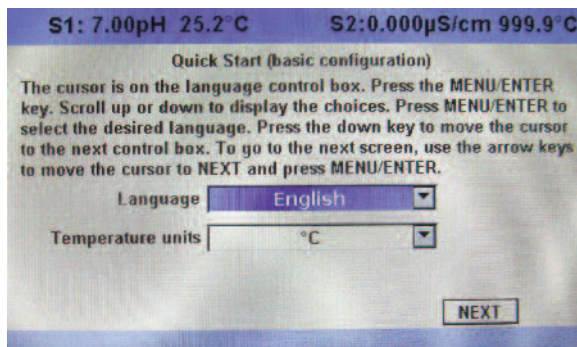

User Help Screens. A complete user guide and trouble-shooting manual is embedded in the instrument’s memory and easily accessed via the INFO key on the keypad. Detailed instructions and troubleshooting tips are intended to provide adequate guidance to resolve most problems on site.

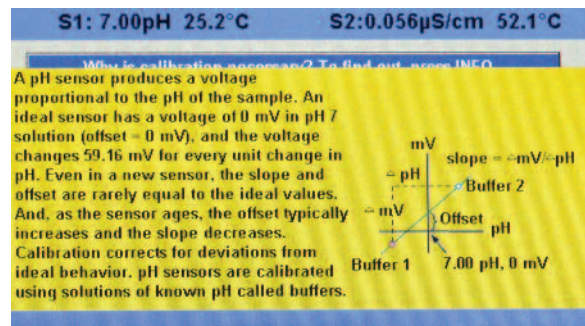

Local Languages: Rosemount Analytical extends its worldwide reach by offering nine menu languages – English, French, German, Italian, Spanish, Portuguese, Chinese, Russian and Polish. Every unit includes user programming menus; calibration routines; and faults and warnings in all nine languages.

Modular, Scalable, Flexible: Slide-in measurement boards allow easy sensor wiring and configuration changes in the field. There are no limitations for measurement or communication configurations.

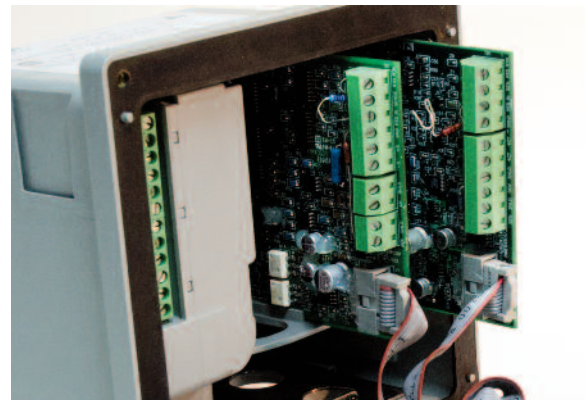

Device Security: Two levels of security access are available. Program one access code for routine maintenance and hold of current outputs; program another access code for all configuration menus and functions.

Diagnostics: The analyzer continuously monitors itself and the sensor(s) for fault and warning conditions. A display banner flashes red to indicate a Fault condition and yellow for a Warning condition to visually alert field personnel. Details and troubleshooting information for any specific fault or warning can be readily accessed by pressing the INFO key.

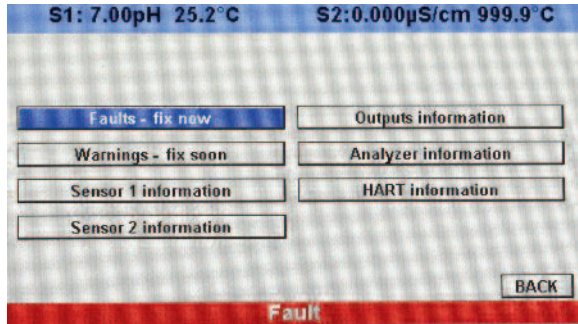

Current Outputs: Every unit includes four actively powered 4-20 mA or 0-20 mA electrically isolated current outputs giving the ability to transmit the measurement value and the temperature for both sensors. Users have wide latitude to assign any measurement value or live diagnostic to any current output for reporting.

Advanced Features

Process trending graphs: High-resolution color graphs of measurement data can be displayed on-screen to pinpoint process disruptions or measurement problems and to estimate probe maintenance frequency. The analyzer gives the user the ability to zoom in to a specific narrow timeframe of process measurements for detailed on-screen evaluation.

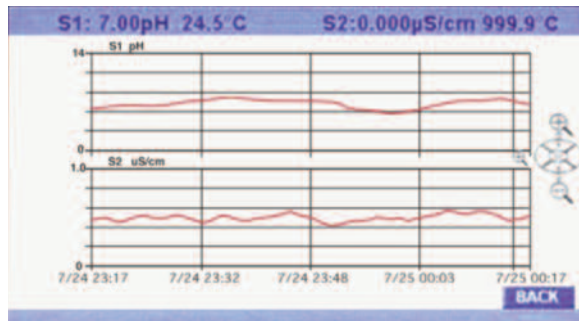

Process trends of any two measurements, temperature or live diagnostics.

Data logger and Event Logger/Audit Trail: Extensive onboard data storage captures measurement data from both channels, including temperature every 30 seconds for 30 days for on-screen display or local upload to a USB 2.0 memory device. 300 significant analyzer events are recorded including start-up time, calibrations, hold outputs, configurations, alarms, power interruptions, faults, and more. All process data and events are time/date stamped.

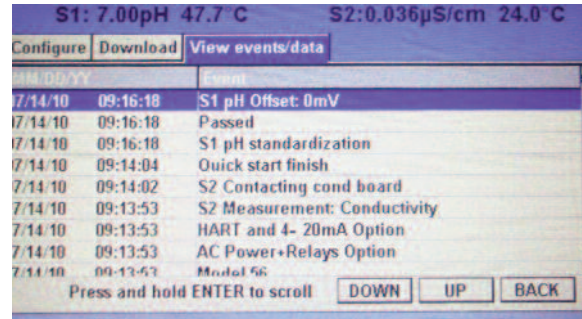

USB 2.0: Local data transfer of process data and events using a standard USB memory device. Cleanly pre-formatted EXCEL data is useful for evaluation of process data on a computer and identification of critical alarm or fault events.



Download data to a standard USB memory device.

Advanced control: Any current output can be programmed for PID functions. Proportional, Integral and Derivative settings allow the analog current outputs to adjust a control device that has continuous adjustability. PID is typically used on modulating control devices such as automated control valves or variable speed pumps.

Alarm relay capabilities: Four SPDT alarm relays are fully assignable and programmable to trigger alarms upon reaching measurement, diagnostics setpoints, or fault conditions. Further relay settings include TPC, synchronized interval timers and four specialized timer functions described below. All relays are independently activated. Failsafe operation and programming of relay default state (normally open or normally closed) is software selectable.

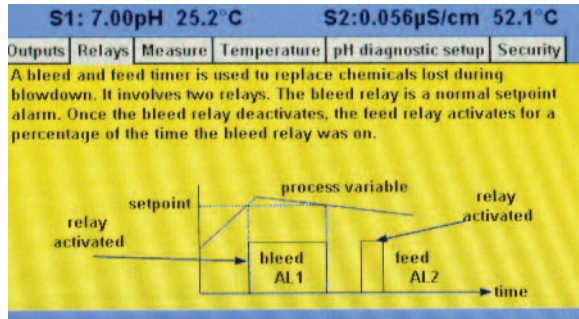

Timer functions: Four real-time clock relay functions are implemented including: bleed and feed, day and time interval timers, delay timer and a flow totalizer. These advanced timer features support a number of specialized applications that normally require dedicated timer control devices or DCS programming. Interval timers set relays by interval time, on-time and recovery time for discrete on/off control devices based on measurement inputs.

Digital Communications: HART version 5 and 7 digital communications are available on Model 56. An optional Profibus DP digital communications board is available for Profibus installations. HART and Profibus DP configured units will support any single or dual measurement configurations of Model 56.



Wireless THUM Adaptor compatible: Enable wireless transmissions of process variables and diagnostics from hard-to-reach locations where it is impractical to run wires for current outputs. When commissioned with the THUM Adaptor, Model 56 HART units can communicate on Emerson wireless networks using HART 7 wireless protocol.

SMART-enabled pH: Rosemount Analytical’s SMART preamplifier pH capability can eliminate field calibration of pH probes through automatic upload of calibration data and history – fully calibrating the pH loop. pH probe changes are literally “plug and play” using SMART pH sensors with VP cables connections.



Safety Approvals:



Enclosure: The instrument enclosure fits standard DIN panel cutouts. The versatile enclosure design supports panel-mount, pipe-mount, and surface/wall-mount installations. Enclosure ratings.

Supports other Advanced Features:

- High reference impedance pH sensors
- Ion Selective Electrode measurements
- pH loop calibration by entering pH slope and reference offset
- Inferred pH determination using dual contacting conductivity inputs
- Differential conductivity
- Differential flow and Totalized flow
- Current input from any 4-20mA source
- Dual range calibration for chlorine sensors
- Programmable polarizing voltage for amperometric oxygen sensors
- Extended high-end conductivity range for contacting conductivity sensors
- Extended low-end conductivity range for inductive conductivity sensors
- Noise immunity to high RF or line noise environments
- Linear or logarithmic setting for current outputs
- Scalable and assignable onscreen trend graphs
- Pre-formatted EXCEL data tables from USB downloads
- Current outputs assignable to any live parameter or diagnostic
- Optimized and programmable input filters

Control Capabilities

Alarm Relays for Diagnostics:

Enable diagnostic setpoint without using 4-20mA outputs.

Control Relay Functions:

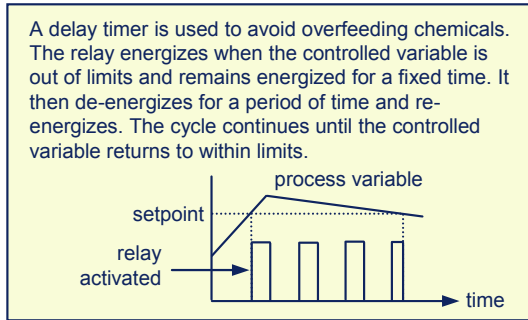

1. High/Low Concentration Alarm

2. **Delay Timer**- Prevent overshooting reagent addition by allowing adequate mixing.

3. TPC Control

* Also known as Duty Cycle on Pulse width modulation.

TPC activates the relay over a defined time period proportional to the deviation of the measurement from the setpoint.

Event Based Relay Activation

1. Bleed and Feed

Activates one relay (feed relay) for a time proportional to the activated time of a second (Bleed) relay. Activation of the feed relay can be delayed by an adjustable delay time.

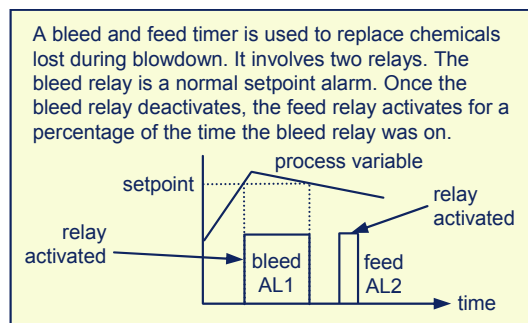

2. Totalizer Based Relay Activation

Activates totalizer flow intervals for an adjustable on time.

Flow input can be from, passive or powered, pulse flow meters or conventional flow meters using the 4-20 mA input card.

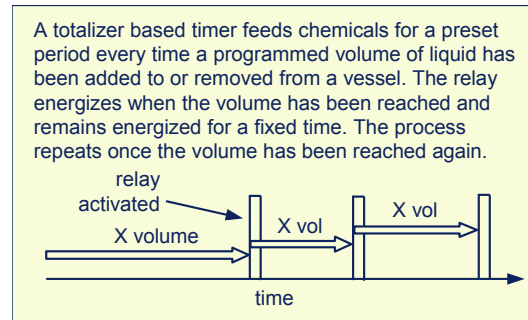

Timer Functions

1. Interval Timer

Activates a recurring cycle of relays purely on a timed basis.

Relay activation occurs at the beginning of the interval, followed by a recovery time, which can be used to hold the measurement output if desired.

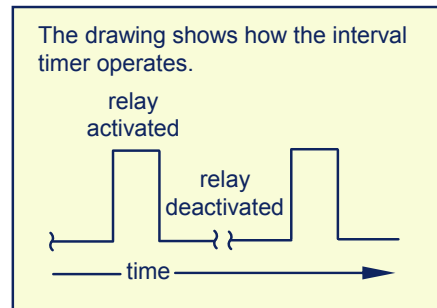

2. Date and Time Activation

Based on the clock and calendar enables relay activation over a 2 week period.

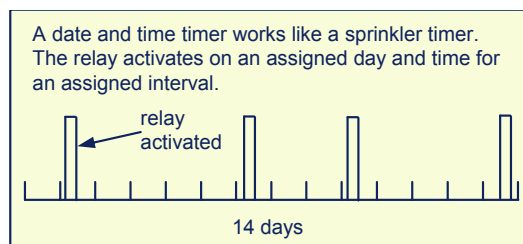

Key 56 Features by Application

APPLICATIONS	Dual Measurement	SMART pH	Inferred pH	High Temp pH	Ion Selective Electrode	Extended Conductivity Range	4 Electrode Conductivity	Differential Conductivity	Timer Relay Control	Time Proportional Control	PID Control	Rapid Response Time	Wireless Reporting	USB Data and Event Logger	Process Trending	Bleed and Feed	External 420mA Input
Cooling Towers	X	X							X	X			X	X	X	X	X
Boiler Blowdown	X	X							X	X	X		X	X	X	X	X
Reverse Osmosis	X	X						X					X	X	X		X
Ion Exchange	X	X			X			X					X	X	X		
Boiler Feedwater	X	X	X	X								X	X	X	X	X	X
Wastewater	X	X			X				X	X	X	X	X	X	X	X	X
Fermenter/ Bioreactor	X	X					X		X	X	X	X	X	X	X		X
Clean in Place	X	X		X		X	X	X	X			X	X	X	X		X
Drinking Water	X	X			X						X		X	X	X		X
Ultrapure Water/ Semiconductor	X	X		X								X	X	X	X		X
Pulp and Paper	X	X		X		X		X			X	X	X	X	X		
Leak Detection	X	X				X		X					X	X	X		
Scrubbers	X	X		X		X			X	X	X	X	X	X	X		X

Specifications

Case: Polycarbonate.

Dimensions: 6.2 x 6.2 x 5.2 in. (157 x 157 x 132mm)

Conduit openings: Accepts (6) PG13.5 or 1/2 in. conduit fittings

Display: Large 3.75 x 2.2 in. (95.3 x 55.9mm) high resolution color LCD displays large process variables and user-definable display of diagnostic parameters. Calibration, programming and information screens display clear, easy-to-read characters. The color display is back-lit and backlighting intensity is user adjustable. Measurement character height: (.5") 13mm. Main display can be customized to meet user requirements.

Ambient temperature and humidity: -10 to 60°C, (14 to 140°F) RH 5 to 95% (non-condensing). For Turbidity only: 0 to 55°C (32 to 131°F). RH 5 to 95% (non-condensing).

Note: Some degradation in display response or performance may occur below -5°C (23°F) and above 55°C (131°F). Above 60°C, the following components will progressively and automatically shut down: display, USB communications port, current outputs, alarm relays, main circuit board.

WARNING: Always remove USB memory device if ambient temp exceeds 60°C. Do not access USB port if combustible atmosphere is present.

Storage temperature: -20 to 60°C, (-4 to 140°F)

Power: Code -02: 20 to 30 VDC, 20 W
Code -03: 85 to 264 VAC, 47.5 to 65.0 Hz, 20 W

Real time clock back-up: 24 hours.

RFI/EMI: - EN-61326 

LVD: - EN-61010-1

Model 56 Hazardous Location Approvals -

Options for CSA: -02, 03, 20, 21, 22, 24, 25, 26, 27, 30, 31, 32, 34, 35, 36, 37, 38, HT and DP.



Class I, Division 2, Groups A, B, C, & D
Class II, Division 2, Groups E, F, & G
Class III T4A Tamb= 50°C

Evaluated to the ANSI/UL Standards. The 'C' and 'US' indicators adjacent to the CSA Mark signify that the product has been evaluated to the applicable CSA and ANSI/UL Standards, for use in Canada and the U.S. respectively

Options for FM: -02, 03, 20, 21, 22, 23, 24, 25, 26, 27, 30, 31, 32, 33, 34, 35, 36, 37, 38, HT and DP.



Class I, Division 2, Groups A, B, C, & D
Class II & III, Division 2, Groups E, F, & G
T4 Tamp = -10 deg C to 60 deg C.

Ordinary Locations (only with -UL ordering option):

Options for UL: -02, 03, 20, 21, 22, 24, 25, 26, 27, 30, 31, 32, 34, 35, 36, 37, 38, HT and DP.



POLLUTION DEGREE 2: Normally only non-conductive pollution occurs. Occasionally, however, a temporary conductivity caused by condensation must be expected.

Altitude: for use up to 2000 meter (6562 ft.)

Pollution Degree 2: Normally only non-conductive pollution occurs. Occasionally, however, a temporary conductivity caused by condensation must be expected.

Altitude: for use up to 2000 meter (6562 ft.)

Input: One or two isolated sensor inputs. Measurement choices of pH/ORP, resistivity/conductivity/TDS, % concentration, ratio conductivity, total and free chlorine, monochloramine, dissolved oxygen, dissolved ozone, turbidity, pulse flow, temperature and raw 4-20mA input. For contacting conductivity measurements, temperature element must be a Pt1000 RTD. For other measurements (except ORP, flow and turbidity), use either a PT100 RTD, PT1000 RTD, or 22k NTC (D.O. only).

Outputs: Four actively powered 4-20 mA or 0-20 mA isolated current outputs. Fully scalable. Max Load: 550 Ohms. Outputs can be programmed for PID control. Output dampening can be enabled with time constants from 0 to 999 seconds. HART digital communications which is superimposed on output 1 is standard on all units (option code -HT).

Alarms: Four alarm relays for process measurement(s) or temperature. Any relay can be programmed for any measurement, timer, TPC or fault alarm operation, instead of a process alarm. When selected, a fault alarm will activate the relay when a sensor or analyzer fault occurs. Each relay can be configured independently. Alarm logic (high or low activation or USP*) and deadband are user-programmable.

*USP alarm can be programmed to activate when the conductivity is within a user-selectable percentage of the limit. *conductivity/resistivity measurement only*

Relays: Form C, SPDT, epoxy sealed

Maximum Relay Current	
Power	Resistive
28 VDC 5.0 A	5.0 A
115 VAC 5.0 A	5.0 A
230 VAC 5.0 A	5.0 A

Inductive load: 1/8 HP motor (max.), 115/240 VAC

Terminal Connections Rating:

Power connector (-02 24VDC power supply and -03 85-264VAC power supply): 24-12 AWG wire size.

Signal board terminal blocks: 26-16 AWG wire size.

Current output connectors: 26-16 AWG wire size.

Alarm relay terminal blocks: 24-12 AWG wire size.

Weight/Shipping Weight: (rounded up to nearest lb or nearest 0.5 kg): 3 lbs/4 lbs (1.5 kg/2.0 kg)

pH/ORP/ISE (Codes -22 and/or -32)

For use with any standard pH or ORP sensors. Measurement choices are pH, ORP, Redox, Ammonium, Fluoride or custom ISE. The automatic buffer recognition feature uses stored buffer pH values and their temperature curves for the most common buffer standards available worldwide. The analyzer will recognize the pH value of the buffer being measured and perform a self-stabilization check on the sensor before completing the calibration. Manual or automatic temperature compensation is menu-selectable. Change in process pH due to temperature can be compensated using a programmable temperature coefficient. For more information concerning the use and operation of the pH or ORP sensors, refer to sensor product data sheets.

Performance Specifications (pH Input) - Analyzer

Measurement Range [pH]: 0 to 14 pH

Accuracy: ± 0.01 pH

Diagnostics: Glass impedance, reference impedance, slope, offset

Temperature coefficient: ± 0.002 pH/°C

Solution temperature correction: pure water, high pH (dilute base), Ammonia and custom.

Buffer Auto-recognition: NIST (including non-NIST pH 7.01 buffer), DIN 19267, Ingold, Merck, and Fisher

Input filter: Time constant 1 - 999 sec, default 4 sec.

Response time: 5 seconds to 95% of final reading

Recommended Sensors for pH:

Compatible with standard pH sensors with and without integral preamps. Supports Smart pH sensors from Rosemount Analytical (includes Smart integral preamps).

Performance Specifications (ORP Input) - Analyzer

Measurement Range [ORP]: -1500 to +1500 mV

Accuracy: ± 1 mV

Temperature coefficient: ± 0.12 mV / °C

Input filter: Time constant 1 - 999 sec, default 4 sec.

Response time: 5 seconds to 95% of final reading

Recommended Sensors for ORP:

Compatible with standard ORP sensors with and without integral preamps.

Note:

Some older sensor preamps may not be compatible with the model 56 (contact the factory for details).



*General purpose and high performance pH sensors
models 3500VP, 3900VP, 396PVP*

Scan with your smart
phone for more
information about
Rosemount Analytical
pH sensors



Contacting Conductivity (Codes -20 and/or -30)

Measures conductivity in the range 0 to 600,000 $\mu\text{S}/\text{cm}$ (600mS/cm). Display unit choices are conductivity, resistivity, total dissolved solids, salinity, and % concentration. Temperature compensation can be disabled, allowing the analyzer to display raw conductivity

Note:

When two contacting conductivity sensors are used, Model 56 can derive an inferred pH value. Inferred pH is calculated pH, not directly measured pH. Inferred pH is calculated from conductivity and cation conductivity. It is applicable only if the alkalizing agent is NaOH or NH₃ and the major contaminant is NaCl. It is strictly an application for power plants.

Performance Specifications - Analyzer

Measurement Range: see table below

Salinity: uses Practical Salinity Scale

Total Dissolved Solids: Calculated by multiplying conductivity at 25°C by 0.65

Five percent concentration curves: 0-12% NaOH, 0-15% HCl, 0-20% NaCl, 0-25% or 96-99.7% H₂SO₄. The conductivity concentration algorithms for these solutions are fully temperature compensated.

Four temperature compensation options: manual slope (X%/°C), high purity water (dilute sodium chloride), cation conductivity (dilute hydrochloric acid) and raw.

Input filter: time constant 1 - 999 sec, default 2 sec.

Response time: 3 seconds to 95% of final reading

PERFORMANCE SPECIFICATIONS

Recommended Range – Contacting Conductivity

Cell Constant	0.01S/cm	0.1 $\mu\text{S}/\text{cm}$	1.0 $\mu\text{S}/\text{cm}$	10 $\mu\text{S}/\text{cm}$	100 $\mu\text{S}/\text{cm}$	1000 $\mu\text{S}/\text{cm}$	10mS/cm	100mS/cm	1000mS/cm
0.01	0.01 $\mu\text{S}/\text{cm}$ to 200 $\mu\text{S}/\text{cm}$			200 $\mu\text{S}/\text{cm}$ to 6000 $\mu\text{S}/\text{cm}$					
0.1	0.1 $\mu\text{S}/\text{cm}$ to 2000 $\mu\text{S}/\text{cm}$				2000 $\mu\text{S}/\text{cm}$ to 60mS/cm				
1.0	1 $\mu\text{S}/\text{cm}$ to 20mS/cm			20mS/cm to 600mS/cm					
4-electrode	2 $\mu\text{S}/\text{cm}$ to 300mS/cm								

Linearity for Standard Cable \leq 50 ft (15 m)*	
	\pm 0.6% of reading in recommended range
	+2 to -10% of reading outside high recommended range
	\pm 5% of reading outside low recommended range
	\pm 4% of reading in recommended range

* Longer cable lengths will degrade performance. For 100 ft (30 m) cable, errors will roughly double. For 200 ft (61 m) cable, errors will roughly double again.

Temperature specifications:

Temperature range	0 to 200°C
Temperature Accuracy, Pt-1000, 0-50°C	\pm 0.1°C
Temperature Accuracy, Pt-1000, Temp. > 50°C	\pm 0.5°C

Recommended Sensors for Contacting Conductivity

All Rosemount Analytical ENDURANCE Model 400 series conductivity sensors (Pt 1000 RTD) and Model 410VP 4-electrode high-range conductivity sensor.

Scan with your smart phone for more information about Rosemount Analytical conductivity sensors.



Toroidal Conductivity (Codes -21 and/or -31)

Measures conductivity in the range of 1 (one) $\mu\text{S}/\text{cm}$ to 2,000,000 $\mu\text{S}/\text{cm}$ (2 S/cm). Display unit choices are conductivity, resistivity, total dissolved solids, salinity, and % concentration. Temperature compensation can be disabled, allowing the analyzer to display raw conductivity.

For more information concerning the use and operation of the toroidal conductivity sensors, refer to the product data sheets.

Performance Specifications - Analyzer

Measurement Range: see table below

Repeatability: $\pm 0.25\%$, $\pm 5 \mu\text{S}/\text{cm}$ after zero cal

Salinity: uses Practical Salinity Scale

Total Dissolved Solids: Calculated by multiplying conductivity at 25°C by 0.65

Five percent concentration curves: 0-12% NaOH, 0-15% HCl, 0-20% NaCl, 0-25% or 96-99.7% H₂SO₄. The conductivity concentration algorithms for these solutions are fully temperature compensated. For other solutions, the analyzer accepts as many as five data points and fits either a linear (two points) or a quadratic function (three or more points) to the data. Reference temperature and linear temperature slope may also be adjusted for optimum results.

Three temperature compensation options: manual slope (X%/°C), neutral salt (dilute sodium chloride) and raw.







Input filter: time constant 1 - 999 sec, default 2 sec.

Response time: 3 seconds to 95% of final reading

Recommended Range - Toroidal Conductivity

Model	1 $\mu\text{S}/\text{cm}$	10 $\mu\text{S}/\text{cm}$	100 $\mu\text{S}/\text{cm}$	1000 $\mu\text{S}/\text{cm}$	10 mS/cm	100 mS/cm	1000 mS/cm	2000 mS/cm
226	•••	5 $\mu\text{S}/\text{cm}$ to 500 mS/cm			500 mS/cm to 2000 mS/cm			
225 & 228	••••••••••	15 $\mu\text{S}/\text{cm}$ to 1500 mS/cm			1500 mS/cm to 2000 mS/cm			
242		100 $\mu\text{S}/\text{cm}$ to 2000 mS/cm						
222 (1in & 2in)		500 $\mu\text{S}/\text{cm}$ to 2000 mS/cm						

LOOP PERFORMANCE (Following Calibration)

-  Model 226: $\pm 1\%$ of reading $\pm 5 \mu\text{S}/\text{cm}$ in recommended range
-  Models 225 & 228: $\pm 1\%$ of reading $\pm 10 \mu\text{S}/\text{cm}$ in recommended range
-  Models 222, 242: $\pm 4\%$ of reading in recommended range
-  Models 225, 226 & 228: $\pm 5\%$ of reading outside high recommended range
-  Model 226: $\pm 5 \mu\text{S}/\text{cm}$ outside low recommended range
-  Models 225 & 228: $\pm 15 \mu\text{S}/\text{cm}$ outside low recommended range

Temperature specifications:

Temperature range	-25 to 210°C (-13 to 410°F)
Temperature Accuracy, Pt-100, -25 to 50 °C	$\pm 0.5^\circ\text{C}$
Temperature Accuracy, Pt-100, 50 to 210°C	$\pm 1^\circ\text{C}$

Recommended Sensors

All Rosemount Analytical submersion/immersion and flow-through toroidal sensors.

Scan with your smart phone for more information about Rosemount Analytical toroidal conductivity sensors



Flow (Code -23 and -33)

For use with most pulse signal flow sensors, the Model 56 user-selectable units of measurement include flow rates in GPM (gallons per minute), GPH (gallons per hour), cu ft/min (cubic feet per min), cuft/hour (cubic feet per hour), LPM (liters per minute), LPH (liters per hour), or m³/hr (cubic meters per hour), and velocity in ft/sec or m/sec. When configured to measure flow, the unit also acts as a totalizer in the chosen unit (gallons, liters, or cubic meters). Dual flow instruments can be configured as a % recovery, flow difference, flow ratio, or total (combined) flow.

Performance Specifications - Analyzer

Frequency Range: 3 to 1000 Hz

Flow Rate: 0 - 99,999 GPM, LPM, m³/hr, GPH, LPH, cuft/min, cuft/hr.

Totalized Flow: 0 – 9,999,999,999,999 Gallons or m³, 0 – 999,999,999,999 cuft.

Accuracy: 0.5%

Input filter: Time constant 0-999 sec., default 5 sec.

Recommended Sensor*

Signet 515 Rotor-X Flow sensor

* Input voltage not to exceed ±36V

4-20mA Current Input (Codes -23 and -33)

For use with any transmitter or external device that transmits 4-20mA or 0-20mA current outputs. Typical uses are for temperature compensation of live measurements (except ORP, turbidity and flow) and for continuous pressure input for continuous measurement of % oxygen gas. External input of atmospheric pressure for oxygen measurement allows continuous partial pressure compensation while the Model 56 enclosure is completely sealed.

Externally sourced current input is also useful for calibration of new or existing sensors that require temperature measurement or atmospheric pressure inputs. In addition to live continuous compensation of live measurements, the current input board can also be used simply to display and trend the measured temperature or the calculated partial pressure from the external device. This feature leverages the large display variables on the Model 56 as a convenience for technicians. Temperature can be displayed in degrees C or degrees F. Partial pressure can be displayed in inches Hg, mm Hg, atm (atmospheres), kPa (kiloPascals), bar or mbar. The current input board serves as a power supply for loop-powered devices that do not actively power their 4-20mA output signals.

Performance Specifications - Analyzer

Measurement Range *[mA]: 0-20 or 4-20

Accuracy: ±0.03mA

Input filter: Time constant 0-999 sec., default 5 sec.

*Current input not to exceed 22mA

Turbidity (Codes -27 and -37)

The Model 56 instrument is available in single and dual turbidity configurations. It is intended for the determination of turbidity in filtered drinking water. The other components of the turbidimeter – sensor(s), debubbler/measuring chamber(s), and cable for each sensor must be ordered separately.

The Model 56 turbidity instrument accepts inputs from both US EPA 180.1 and ISO 7027-compliant sensors. Four fully programmable relays with timers are included.

Recommended Sensor:

Model 56 Turbidity must be used with Clarity II sensors (PN 8-0108-0002-EPA or PN 8-0108-0003-ISO), sensor cable and debubbler.

Performance Specifications - Analyzer

Units: Turbidity (NTU, FTU, or FNU); total suspended solids (mg/L, ppm, or no units)

Calibration methods: User-prepared standard, commercially prepared standard, or grab sample. For total suspended solids user must provide a linear calibration equation.

Inputs: Single or dual input, EPA 180.1 or ISO 7027 sensors.

Accuracy after calibration at 20.0 NTU: 0-20 NTU ±2% of reading or 0.015 NTU, whichever is greater.

Chlorine (Code -24 and -34)

Free and Total Chlorine

The Model 56 is compatible with the Model 499ACL-01 free chlorine sensor and the Model 499ACL-02 total chlorine sensor. The Model 499ACL-02 sensor must be used with the Model TCL total chlorine sample conditioning system. The Model 56 fully compensates free and total chlorine readings for changes in membrane permeability caused by temperature changes. For free chlorine measurements, both automatic and manual pH correction are available. For automatic pH correction, select code -32 and an appropriate pH sensor. For more information concerning the use and operation of the amperometric chlorine sensors and the TCL measurement system, refer to the product data sheets.

Performance Specifications - Analyzer

Resolution: 0.001 ppm or 0.01 ppm – selectable

Input Range: 0nA – 100 μ A

Automatic pH correction (requires Code -32): 6.0 to 10.0 pH

Temperature compensation: Automatic or manual (0-50°C).

Input filter: Time constant 1 - 999 sec, default 5 sec.

Response time: 6 seconds to 95% of final reading

Recommended Sensors

Chlorine: Model 499ACL-01 Free Chlorine or Model 499ACL-02 Total Chlorine

pH correction of free chlorine readings: Model 3900



Free Chlorine sensor Model 499ACL-01

pH-Independent Free Chlorine

The Model 56 is compatible with the Model 498CL-01 pH-independent free chlorine sensor. The Model 498CL-01 sensor is intended for the continuous determination of free chlorine (hypochlorous acid plus hypochlorite ion) in water. The primary application is measuring chlorine in drinking water. The sensor requires no acid pre-treatment, nor is an auxiliary pH sensor required for pH correction. The Model 56 fully compensates free chlorine readings for changes in membrane permeability caused by temperature. For more information concerning the use and operation of the amperometric chlorine sensors, refer to the product data sheets.

Performance Specifications - Analyzer

Resolution: 0.001 ppm or 0.01 ppm – selectable

Input Range: 0nA – 100 μ A

pH independent

Temperature compensation: Automatic (via RTD) or manual (0-50°C).

Input filter: Time constant 1 - 999 sec, default 5 sec.

Response time: 6 seconds to 95% of final reading

Recommended Sensors

Rosemount Analytical Model 498CL-01 pH independent free chlorine sensor



Chlorine sensor Model 498CL-01

Monochloramine

The Model 56 is compatible with the Model 499A CL-03 Monochloramine sensor. The Model 56 fully compensates readings for changes in membrane permeability caused by temperature changes. Because monochloramine measurement is not affected by pH of the process, no pH sensor or correction is required. For more information concerning the use and operation of the amperometric chlorine sensors, refer to the product data sheets.



Monochloramine sensor Model 499ACL-03

Performance Specifications

Resolution: 0.001 ppm or 0.01 ppm – selectable

Input Range: 0nA – 100 μ A

Temperature compensation: Automatic or manual (0-50°C).

Input filter: Time constant 1 - 999 sec, default 5 sec.

Response time: 6 seconds to 95% of final reading

Recommended Sensors

Rosemount Analytical Model 499ACL-03 Monochloramine sensor

Scan with your smart phone for more information about Rosemount Analytical chlorine sensors



Dissolved Oxygen (Codes -25 and -35)

The Model 56 is compatible with the Model 499ADO, 499ATrDO, Hx438, Gx438 and BX438 dissolved oxygen sensors and the Model 4000 percent oxygen gas sensor. The Model 56 displays dissolved oxygen in ppm, mg/L, ppb, µg/L, % saturation, % O₂ in gas, ppm O₂ in gas. The analyzer fully compensates oxygen readings for changes in membrane permeability caused by temperature changes. An atmospheric pressure sensor is included on all dissolved oxygen signal boards to allow automatic atmospheric pressure determination during air calibration. Calibration can be corrected for process salinity if removing the sensor from the process liquid is impractical. The analyzer can be calibrated against a standard instrument. For more information on the use of oxygen sensors, refer to the product data sheets.

Performance Specifications

Resolution: 0.01 ppm; 0.1 ppb for 499A TrDO sensor (when O₂ <1.00 ppm); 0.1%

Input Range: 0nA – 100µA

Temperature Compensation: Automatic or manual (0-50°C).

Input filter: Time constant 1 - 999 sec, default 5 sec.

Response time: 6 seconds to 95% of final reading

Recommended Sensors

Rosemount Analytical amperometric membrane and steam-sterilizable sensors listed above



*Dissolved Oxygen sensor with Variopol connection
Model 499ADO*

Dissolved Ozone (Code -26 and -36)

The Model 56 is compatible with the Model 499AOZ sensor. The Model 56 fully compensates ozone readings for changes in membrane permeability caused by temperature changes. For more information concerning the use and operation of the ozone sensor, refer to the product data sheet.

Performance Specifications - Analyzer

Resolution: 0.001 ppm or 0.01 ppm – selectable

Input Range: 0nA – 100µA

Temperature Compensation: Automatic or manual (0-35°C)

Input filter: Time constant 1 - 999 sec, default 5 sec.

Response time: 6 seconds to 95% of final reading

Recommended Sensor

Rosemount Analytical ozone sensor



*Dissolved Ozone sensors with Polysulfone body
Variopol connection and cable connection
Model 499AOZ*

Scan with your smart phone for more information about Rosemount Analytical dissolved oxygen and ozone sensors



Model 56 Panel Mounting Installation dimensions

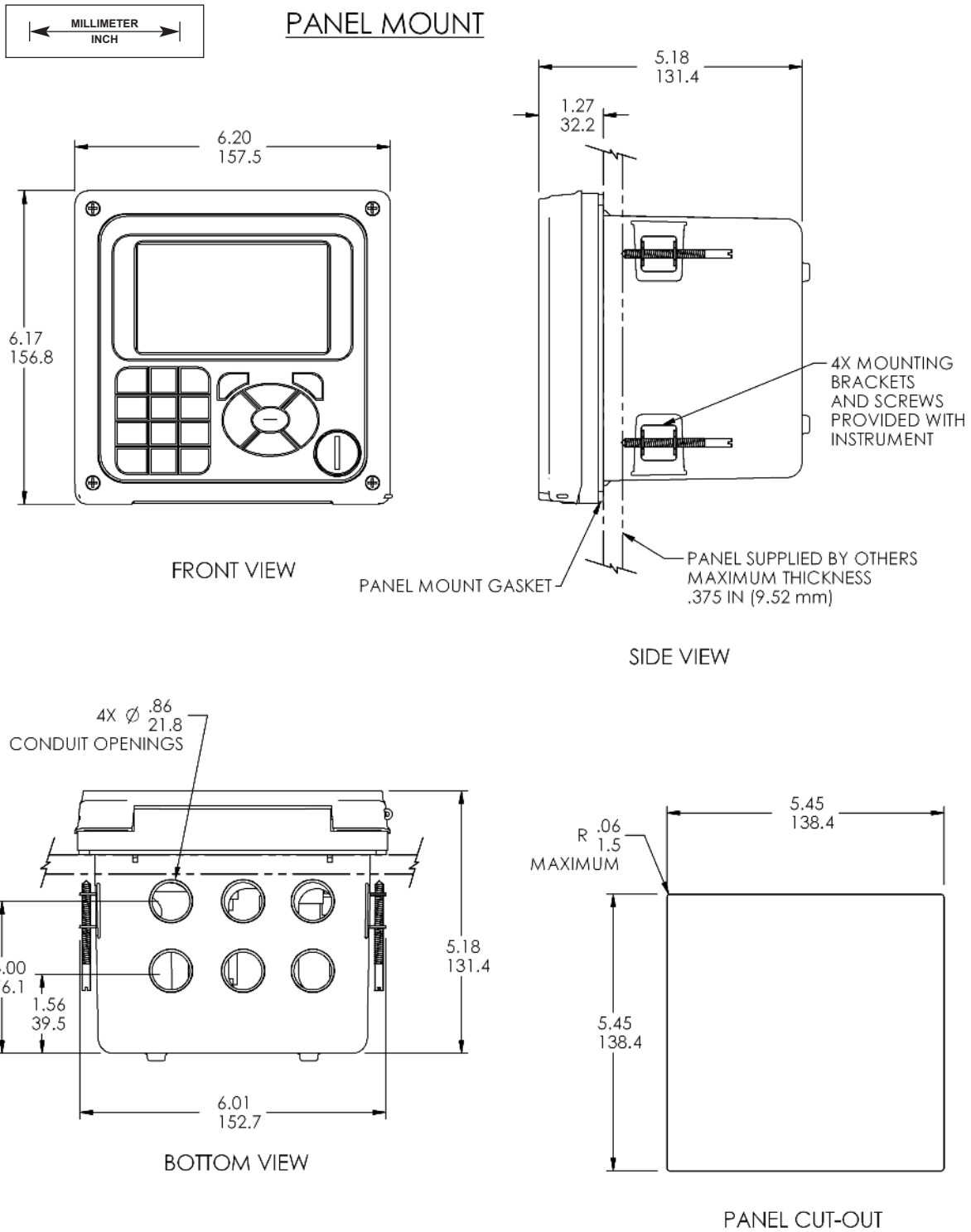

Model 56 Pipe and Wall/Surface Mounting Installation dimensions

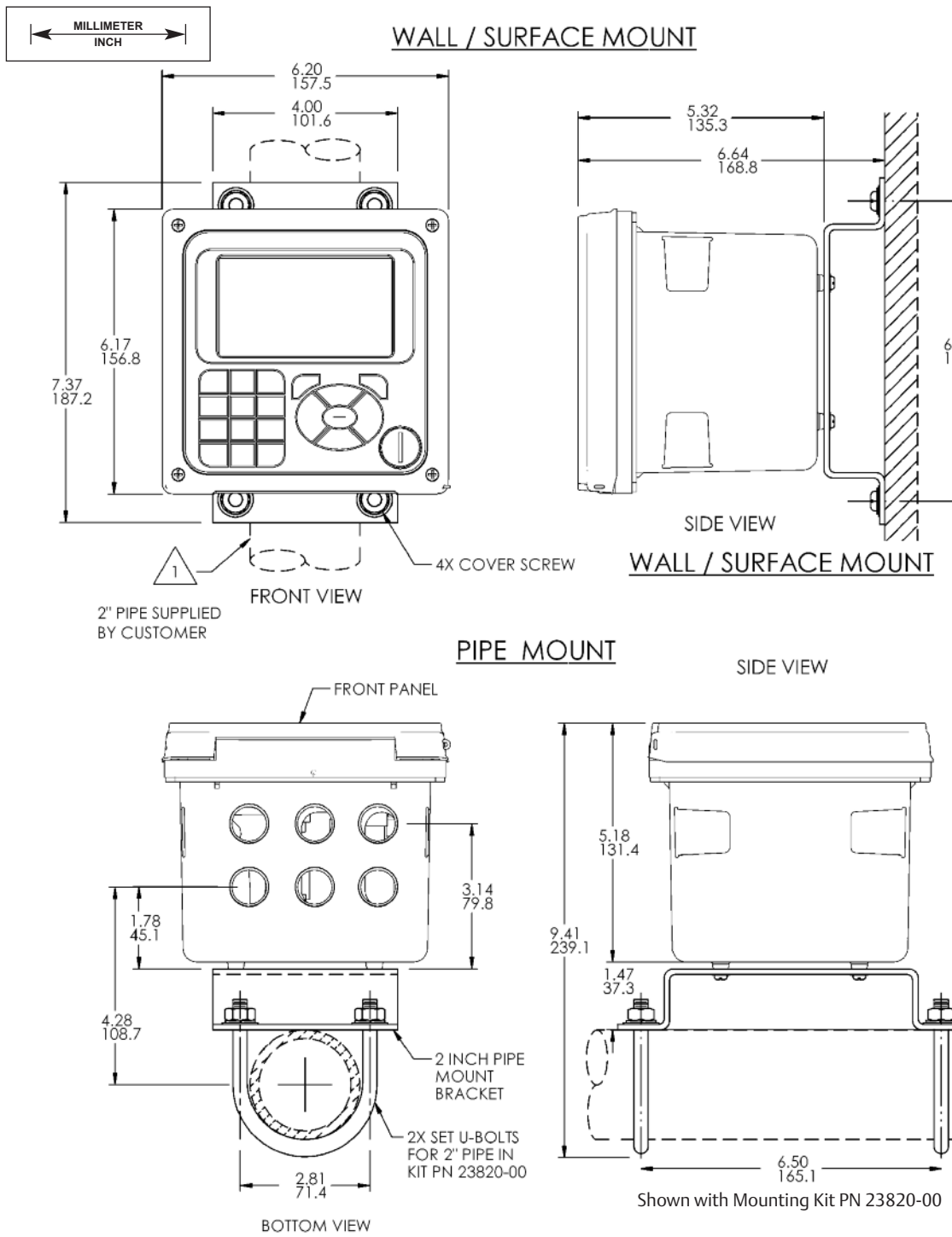

Ordering Information

The Model 56 Analyzer offers single or dual sensor input with an unrestricted choice of dual measurement combinations. Measurements capabilities include pH, ORP, ISE, Resistivity/ Conductivity, % Concentration, Total Chlorine, Free Chlorine, Monochloramine, Dissolved Oxygen, Dissolved Ozone, Turbidity, Pulse Flow, Temperature, and 4-20mA input.

Model 56 Advanced Dual-Input Analyzer	
Level 1	Power
02	20-30 VDC with four alarm relays
03	85-264 VAC switching, 50/60 Hz with four alarm relays
Level 2	Measurement 1
20	Contacting Conductivity
21	Toroidal Conductivity
22	pH/ORP/ISE
23	Flow/4 to 20mA Current Input
24	Chlorine
25	Dissolved Oxygen
26	Ozone
27	Turbidity
Level 3	Measurement 2
30	Contacting Conductivity
31	Toroidal Conductivity
32	pH/ORP/ISE
33	Flow/4 to 20mA Current Input
34	Chlorine
35	Dissolved Oxygen
36	Ozone
37	Turbidity
38	None
Level 4	Communications
HT	HART® digital communication
DP	Profibus® DP digital communication

Authorized Distributor:
GasDetectorsUSA.com
Houston, TX USA
832-615-3588
sales@GasDetectorsUSA.com

Scan with your smart phone for more information about Rosemount Analytical Model 56.



© 2012 Emerson Process Management. All rights reserved.

The Emerson logo is a trademark and service mark of Emerson Electric Co. Rosemount Analytical is a mark of one of the Emerson Process Management family of companies. All other marks are the property of their respective owners.

The contents of this publication are presented for information purposes only, and while effort has been made to ensure their accuracy, they are not to be construed as warranties or guarantees, express or implied, regarding the products or services described herein or their use or applicability. All sales are governed by our terms and conditions, which are available on request. We reserve the right to modify or improve the designs or specifications of our products at any time without notice.