



Gas and Flame Detection

Operation and Maintenance Manual

GASMAX II Single / Dual Channel Gas Monitor

AUTHORIZED DISTRIBUTOR

GasDetectorsUSA.com - Houston, Texas USA

sales@GasDetectorsUSA.com - 281-643-0080

GDS Corp.

1245 Butler Road • League City, TX 77573
409-927-2980 • 409-927-4180 (Fax) • www.gdscorp.com

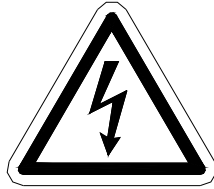

CAUTION: FOR SAFETY REASONS THIS EQUIPMENT MUST BE OPERATED AND SERVICED BY QUALIFIED PERSONNEL ONLY. READ AND UNDERSTAND INSTRUCTION MANUAL COMPLETELY BEFORE OPERATING OR SERVICING.

ATTENTION: POUR DES RAISONS DE SÉCURITÉ, CET ÉQUIPEMENT DOIT ÊTRE UTILISÉ, ENTRETENU ET RÉPARÉ UNIQUEMENT PAR UN PERSONNEL QUALIFIÉ. ÉTUDIER LE MANUE D'INSTRUCTIONS EN ENTIER AVANT D'UTILISER, D'ENTREtenir OU DE RÉPARER L'ÉQUIPEMENT.

REVISION HISTORY

Revision 7.0 7/16/16 General update

CONTENTS

1	SAFETY INFORMATION	6
2	OVERVIEW	7
3	INSTALLATION	9
4	INITIAL SETUP	23
5	CALIBRATION	29
6	MAINTENANCE	31
7	USER MENUS	33
8	TROUBLESHOOTING	44
9	MODBUS INTERFACE	47
10	SPECIFICATIONS	51
11	SPARE PARTS	52
12	DRAWINGS AND DIMENSIONS	56

TABLE OF FIGURES

FIGURE 4-1: GASMAX II POWER & SIGNAL WIRING	10
FIGURE 4-2: OPTIONAL RELAY / MODBUS INTERFACE BOARD.....	11
FIGURE 4-3: MODBUS WIRING (TYPICAL).....	12
FIGURE 4-4: MODBUS WIRING (MODBUS JUNCTION BOX).....	13
FIGURE 4-5: MODBUS JBOX INSTALLATION OPTIONS	13
FIGURE 4-6: OPTIONAL DUAL ISOLATED 4-20MA OUTPUT	14
FIGURE 4-7: LOCAL SMART TOXIC SENSOR CONNECTION	15
FIGURE 4-8: REMOTE TOXIC SENSOR CONNECTION	16
FIGURE 4-9: CHANNEL 1 REMOTE TOXIC SENSOR TRANSMITTER (10-0233-D4).....	17
FIGURE 4-10: CHANNEL 1 REMOTE TOXIC SENSOR TRANSMITTER (10-0233-B4).....	17
FIGURE 4-11: LOCAL SMART BRIDGE SENSOR CONNECTION	18
FIGURE 4-12: REMOTE BRIDGE SENSOR CONNECTION	19
FIGURE 4-13: REMOTE SENSOR TRANSMITTER CONNECTION	20
FIGURE 4-14: REMOTE 4-20MA INPUT (CH 2)	21
FIGURE 4-15: DUAL 4-20MA INPUT OPTION	22
FIGURE 5-1: GASMAX SINGLE CHANNEL DISPLAY	23
FIGURE 5-2: GASMAX DUAL CHANNEL DISPLAY	23
FIGURE 5-3: USER MENU SCREEN.....	24
FIGURE 5-4: ACCESSING CAL MODE	24
FIGURE 5-5: GASMAX DATA DISPLAY	25
FIGURE 5-6: GASMAX TREND DISPLAY	25
FIGURE 6-1: CALIBRATION FLOWCHART	29
FIGURE 7-1: GASMAX SENSOR REPLACEMENT.....	31
FIGURE 8-1: MAIN MENU FLOWCHART.....	33
FIGURE 8-2: SYSTEM CONFIG MENU	34
FIGURE 8-3: SENSOR LIFE TRANSMISSION FORMAT	35
FIGURE 8-4: ALARM SETTINGS MENU	36
FIGURE 8-5: RS-485 MODBUS MENU	37
FIGURE 8-6: SENSOR SETTINGS MENU	37
FIGURE 8-7: CLOCK DELAY MENU.....	38
FIGURE 8-8: CONTRAST MENU	38
FIGURE 8-9: DIAGNOSTICS MENU	38
FIGURE 8-10: SYSTEM SECURITY MENU	39
FIGURE 9-1: XMITTER CONFIG MENU	40

FIGURE 9-2: TECHNICAL PAGE MENU.....	41
FIGURE 9-3: SENSOR BALANCE & VOLTAGE SET MENU	42
FIGURE 9-4: SET GAIN TO UNITY MENU	42
FIGURE 9-5: PREAMP GAIN SET MENU.....	42
FIGURE 13-1: GASMAX II + LOCAL SENSOR SPARE PARTS	52
FIGURE 13-2: GASMAX SENSOR HEAD	52
FIGURE 13-3: GASMAX EXPANSION BOARDS	53
FIGURE 13-4: GASMAX SENSOR HEAD SPLASH GUARD & FLOW CELL	53
FIGURE 13-5: GASMAX II REMOTE DIRECT SENSOR HEAD	54
FIGURE 13-6: GASMAX II REMOTE SENSOR TRANSMITTER.....	54
FIGURE 13-7: GASMAX II DUAL WITH Y-ADAPTER.....	55
FIGURE 14-1: GASMAX DIMENSIONS	56
FIGURE 14-2: GASMAX DUAL LOCAL SENSOR DIMENSIONS	56

1 SAFETY INFORMATION

Important – Read Before Installation

Users should have a detailed understanding of GASMAX II operating and maintenance instructions. Use the GASMAX II only as specified in this manual or detection of gases and the resulting protection provided may be impaired. Read the following WARNINGS prior to use.

WARNINGS

- **CAUTION:** KEEP EXPLOSION PROOF COVER TIGHT WHILE CIRCUITS ARE ALIVE
- **MISE EN GARDE :** GARDER EXPLOSION COUVERTURE PREUVE TIGHT CIRCUITS PENDANT QUE SONT ALIVE
- Unit must be installed, operated and maintained in accordance with information contained herein. Installation in any hazardous area must comply with all applicable restrictions, requirements and guidelines for said hazardous areas. It is the end user customer's final decision to ensure that the GASMAX II is suitable for the intended use.
- The GASMAX II is designed and constructed to measure the level of certain gases in ambient air. Accuracy in atmospheres containing steam or inert gases cannot be guaranteed.
- Always mount the sensor head vertically with the sensor head facing down. However, the GDS-IR infrared sensor may be mounted vertically or horizontally.
- Do not paint transmitter or sensor assembly.
- Do not operate the GASMAX II if its enclosure is damaged or cracked or has missing components. Make sure the cover, internal PCB's and field wiring are securely in place before applying power.
- Do not expose the GASMAX II to electrical shock or continuous severe mechanical shock. Protect the GASMAX II and related sensor assemblies from dripping liquids and high power sprays.
- Calibrate with known target gas at start-up and check on a regular schedule, at least every 90 days. More frequent inspections are encouraged to spot problems such as dirt, oil, paint, grease or other foreign materials on the sensor head.
- Periodically test for correct operation of the system's alarm events by exposing the monitor to a targeted gas concentration above the High Alarm set point.
- Use only for applications described within this manual.

2 OVERVIEW

The GASMAX II is a single or dual channel fixed-point gas monitor designed to provide continuous monitoring of toxic or combustible gases in hazardous areas. Gas values are displayed in calibrated engineering units as well as bar graph or 30-minute trend graph format.

The GASMAX II supports one or two local or remote sensors for toxic or combustible gases. The advanced microcontroller, non-intrusive magnetic interface and superior graphic LCD interface offers rapid setup, simplified operation and enhanced diagnostics not found in previous generation products. On-board non-volatile memory retains all configuration data during power interruptions. Two independent 4-20 mA outputs allow for easy connection to control systems or other alarm instrumentation. Additional output options include alarm relays and single or dual channel MODBUS slave interfaces.

Built-in user-prompted calibration makes it easy for one person to perform calibration and maintenance without opening the enclosure or declassifying the area. A battery-powered real-time clock and event log allows the GASMAX II to track calibration and alarm events for later recall on the LCD readout.

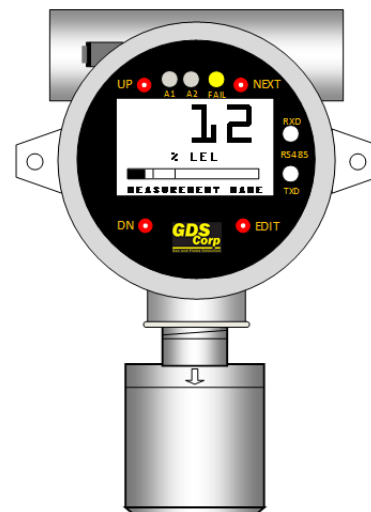

GASMAX II SENSORS

The GASMAX II supports a number of different sensors that fall into two categories – “toxic” and “bridge”. Toxic sensors use an electrochemical process to detect gas and are often referred to as “echem” sensors. Examples include oxygen, hydrogen sulfide and mercaptan. Toxic sensors require no excitation voltage and – when operating properly – generate zero output when no gas is present.

Bridge sensors require an excitation voltage to operate and generate an output signal that is biased at approximately ½ of the input and varies by a small amount proportional to the amount of gas present. These sensors require both a VOLTAGE adjustment and a BALANCE adjustment and include catalytic beads, SmartIR infrared sensors and PID photoionization detectors.

In the standard configuration, Channel 1 is configured to accept a toxic sensor and Channel 2 is configured for a bridge sensor. Channel 2 can also be modified to support an industry standard 4-20mA input.

IMPORTANT: TOXIC SENSORS MAY FAIL TO OPERATE PROPERLY IF POWER IS NOT APPLIED WITHIN 6 MONTHS OF SHIPMENT. CONTACT GDS CORP FOR RECOMMENDATIONS IF THIS SITUATION MAY OCCUR.

The GASMAX II consists of a display assembly with optional MODBUS + alarm relay interface, I/O power supply board, sensor head body, sensor head cover and sensor.

The display assembly contains the microprocessor, LCD display, magnetic switches, alarm indication LEDs and toxic sensor interface electronics (Channel 1). The display connects to the I/O power supply board via a short ribbon cable. This cable should remain connected at all times. If a local toxic sensor is connected to the GASMAX II, it connects to the "S1" connector on the back of the display.

If the GASMAX II is equipped with the optional MODBUS + relay interface board, this board is mounted to the back of the display using three extended length 4-40 screws. The GASMAX II software automatically recognizes the presence of the MODBUS + relay interface board if installed.

The display and optional MODBUS + relay interface board are attached to the I/O power supply board using standoffs and thumbscrews. To access the I/O power supply board, loosen the thumbscrews and allow the display to hang by the ribbon cable. This can be done without removing power to the unit.

The I/O power supply board is mounted on the back side of the enclosure and provides power management, signal output and bridge input circuitry. Connections for power input and signal output are provided on the left-hand side terminal strip and connections for a remote bridge sensor or 4-20mA input (Channel 2) are provided on the right-hand side terminal strip.

There are four distinct I/O power supply board types. The standard 10-0233 I/O board has channel 2 input type configured for bridge sensors. The 10-0233-420 board has channel 2 configured for 4-20mA input. The 10-0233-D4 board has dual 4-20mA inputs for both channel 1 and channel 2. The 10-0233-B4 board has channel 1 configured for 4-20mA and channel 2 configured for bridge input. These configurations are factory selected during manufacturing and cannot be modified in the field.

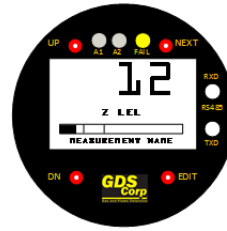

Display Front

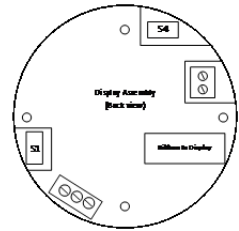

Display Back

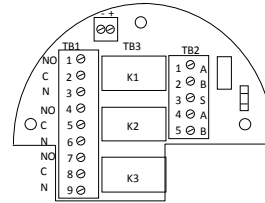

Optional MODBUS + relays
Mounts on display back

Enclosure with I/O power
supply board

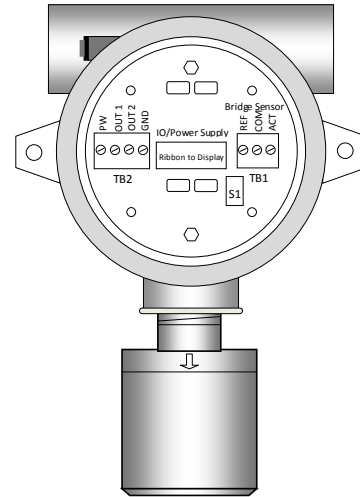

Sensor Head
Sensor Head Cover
Sensor Element

3 INSTALLATION

SELECTING A LOCATION

Factors such as prevailing winds, gas density, potential leak sources, air movement machinery and similar environmental variables are important when selecting a location for the GASMAX II gas monitor or gas sensor. Even though the GASMAX II is designed for rugged service, sensors and electronics should be protected from environmental damage due to water, snow, shock, vibration and dirt.

In addition, the sensor and / or display should be located such that regular maintenance and periodic sensor replacement can be readily accomplished. While there are no industry standards for gas detector placement, professional tools exist that can simulate leaks or spills and provide excellent guidance for locating gas detectors throughout a facility.

MOUNTING THE GASMAX II

The GASMAX II standard enclosure is a cast aluminum explosion-proof (NEMA 7) enclosure. Two channel GASMAX II units with dual local sensor heads include a "Y" adapter, shown at right. Mounting ears are located on both sides of the enclosure.

The GASMAX II or remote sensor should always be mounted with the sensor head opening facing down. If necessary, a Splash Guard (p/n 10-0205) should be attached if there is any chance that water or liquid spray could enter the sensor opening from below. Be sure to leave sufficient room (6"-8") below the sensor head to allow for air flow, easy access for attachment of a Calibration Cup and / or removal of the sensor head cover for sensor replacement.

MOUNTING A REMOTE SENSOR

GASMAX II remote sensors consist of a cast aluminum explosion-proof junction box and stainless steel sensor head. The junction box contains a PCB with an interface for the sensor head cable and wiring terminals for the three-wire connection to the GASMAX monitor.

Fittings are all ¼" NPT. The sensor head should always be mounted vertically as shown, and GDS Corp recommends side entry for all conduit runs. GASMAX monitors support up to two remote sensors.

EXPLOSION PROOF INSTALLATION

GASMAX II monitors with standard explosion-proof sensor heads are certified for use in Class 1 Division 1 hazardous areas. Installation in these areas should follow required industry standard practices and all appropriate electrical codes. Generally, these codes require rigid metal conduit, poured seals and other installation elements necessary to ensure safety.

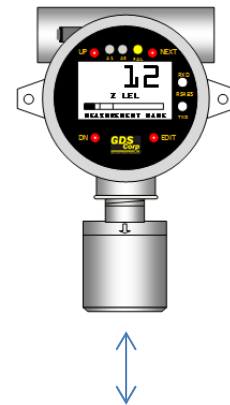

Leave 8-12" open space below gas detector for air flow, sensor maintenance and calibration



GASMAX II Remote Sensor

For maximum protection against RF interference or electrical surge, the GASMAX II enclosure, all remote sensors and interconnecting conduit must be properly grounded.

CAUTION: KEEP EXPLOSION PROOF COVER TIGHT WHILE CIRCUITS ARE ALIVE

MISE EN GARDE : GARDER EXPLOSION COUVERTURE PREUVE TIGHT CIRCUITS PENDANT QUE SONT ALIVE

INTRINSICALLY SAFE INSTALLATION

The GASMAX II is not certified for use as an Intrinsically Safe device. Any GASMAX II that does not include a flame arrestor in the sensor should be used in general purpose areas only.

CONNECTING DC POWER & OUTPUT SIGNAL WIRING

To access the GASMAX signal and power connections, remove the cover on the GASMAX II explosion-proof enclosure, loosen the 2 thumbscrews holding the display assembly and remove it. The display will remain connected to the IO/Power Supply PCB mounted in the back of the enclosure by a short ribbon cable. Route the power and signal wires through the conduit entry and connect to terminal block “TB2”.

Plus 24VDC connects to TB2-1. DC Ground connects to TB2-4. Channel One 4-20mA output is available on TB2-2 and Channel Two 4-20mA output is available on TB2-3.

GDS Corp always recommends using shielded wire for signal and power cable.

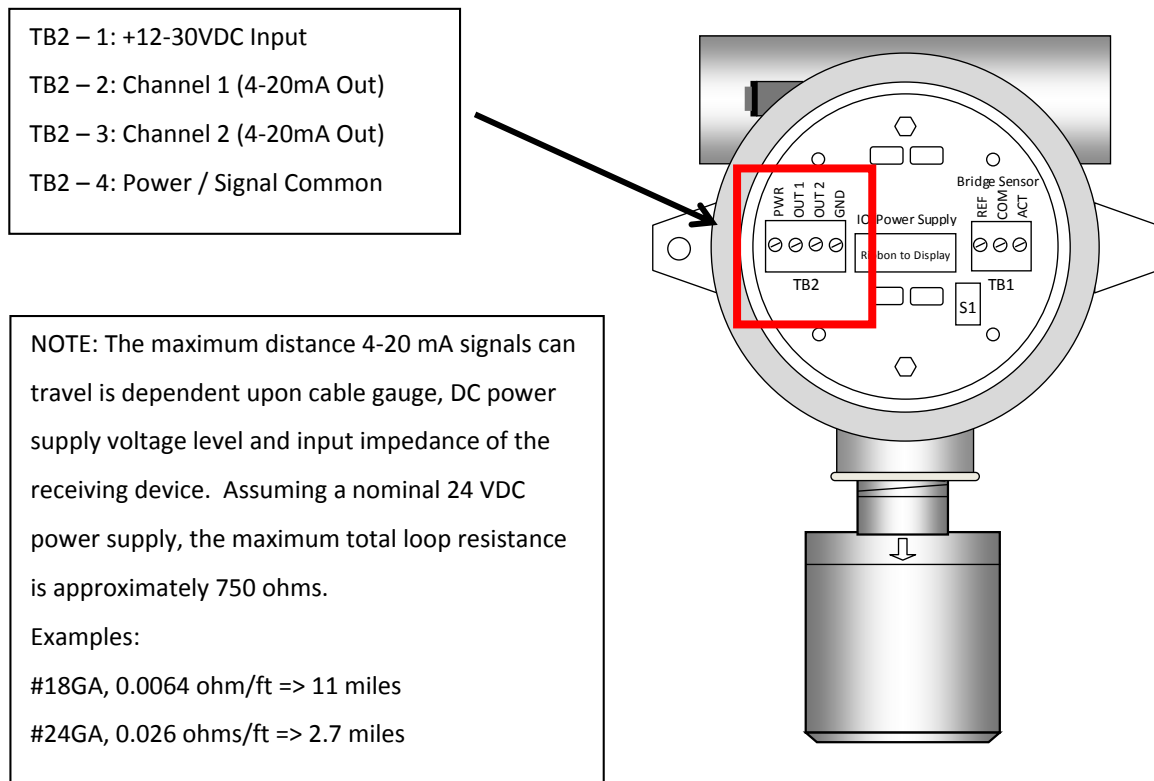

Figure 3-1: GASMAX II Power & Signal Wiring

OPTIONAL RELAY + MODBUS INTERFACE

The optional 10-0234 Relay / Modbus board is connected “piggyback” to the back of the GASMAX II Display Assembly and supplies two level alarm relays (“K1” and “K2”), a FAULT relay (“K3”) and an RS-485 Modbus RTU slave port. If dual isolated 4-20mA outputs are *not* installed, GASMAX II units may be field upgraded with this option at any time.

RELAY FUNCTIONALITY

Alarm relays are dry contact SPDT and may be configured as normal or failsafe (“normally open held closed”). Power must be supplied from an external source and should be fused.

WARNING: CONTACTS ARE RATED FOR RESISTIVE LOADS ONLY! INDUCTIVE LOADS, SUCH AS COILS, MOTORS OR SOLENOID VALVES MAY CAUSE ARCING WHICH SHORTENS LIFE AND MAY INTERFERE WITH SENSOR DATA.

Relay K1 activates if either Channel 1 or Channel 2 exceed the programmed alarm 1 threshold and cannot be acknowledged. Relay K2 activates if either Channel 1 or Channel 2 exceed the programmed alarm 2 threshold and can be acknowledged (reset) from the front panel or via TB3. Relay K3 indicates sensor failure and is always failsafe (normally open held closed).

Remote Alarm Reset (TB3) can be used to acknowledge an Alarm 2 relay contact closure via a remote pushbutton. Use a momentary dry-contact normally-open switch between “+” and “-” to force a reset. Wiring from any remote pushbutton to TB3 should be shielded and protected from noise spikes to prevent false Alarm Reset commands.

A version of this board is available with MODBUS RTU slave only configuration (No relays).

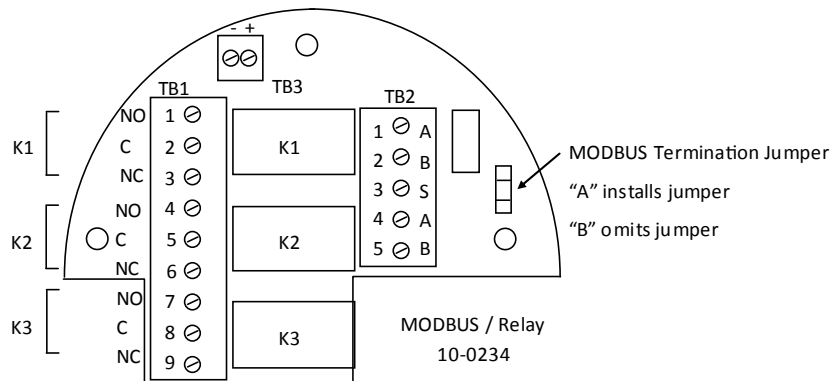

Figure 3-2: Optional Relay / MODBUS Interface Board

MODBUS WIRING

Typical MODBUS wiring is shown in Figure 4-6. MODBUS system architecture requires that the devices in any MODBUS loop be connected in a daisy-chain layout. This minimizes signal reflections and improves signal noise margin. A MODBUS Termination Jumper installs a load resistor across the MODBUS signal lines and should only be set to “A” (ON) **at the last device in the string.**

Cable selection for MODBUS systems is important for both signal integrity and power distribution. MODBUS / RS-485 transmissions use low-voltage differential signaling to achieve reasonable data rates over very long distances, up to 4000 feet without a repeater. For MODBUS data signals, GDS Corp recommends 24GA shielded cable for best results. Power distribution, however may require larger gauge wire since it is critical that the supply voltage for the GASMAX at the far end of the string not fall below 12VDC during power-up and normal operation. If the GASMAX includes a GDS-IR infrared sensor, the voltage must not be allowed to drop below 18V on power-up.

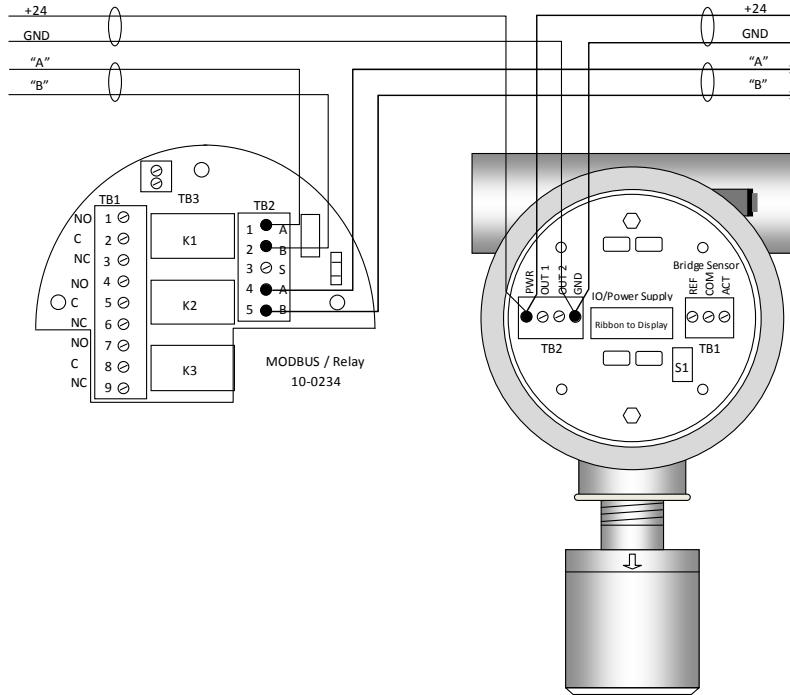

Figure 3-3: MODBUS Wiring (Typical)

Note that while the GASMAX has two sets of wiring terminals for MODBUS “A” and “B” signals, daisy-chain power wiring requires that two wires be installed in the “+24” and “GND” terminals on the GASMAX I/O Power Supply board. This can be difficult if wire sizes are larger than #18ga. Further, the addition of multiple MODBUS and power wires inside the GASMAX enclosure can create problems and possibly damage components if the display has to be forced into place. Finally, if it is desired to disconnect the GASMAX from the MODBUS loop for troubleshooting, disconnecting the power wire removes power from all devices further down the loop and leaves a live male pin with +24V inside the enclosure.

For these reasons, GDS Corp recommends the addition of the MODBUS Wiring Junction Box (see Fig. 4-7). This option minimizes the need to access wiring inside the GASMAX II, provides individual wire landing points for incoming and outgoing MODBUS and power wiring and shields, and makes it easy to temporarily disconnect the GASMAX II power or MODBUS connections without affecting any other MODBUS devices.

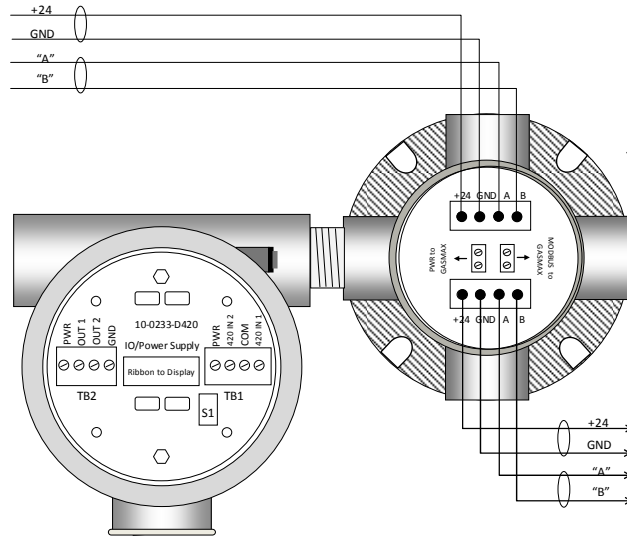

Figure 3-4: MODBUS Wiring (MODBUS Junction Box)

The MODBUS wiring junction box is attached to the GASMAX, either on the bottom fitting or one of the side fittings, depending on installation requirements. Specify BOTTOM, LSIDE or RSIDE when ordering (See Fig. 4-8).

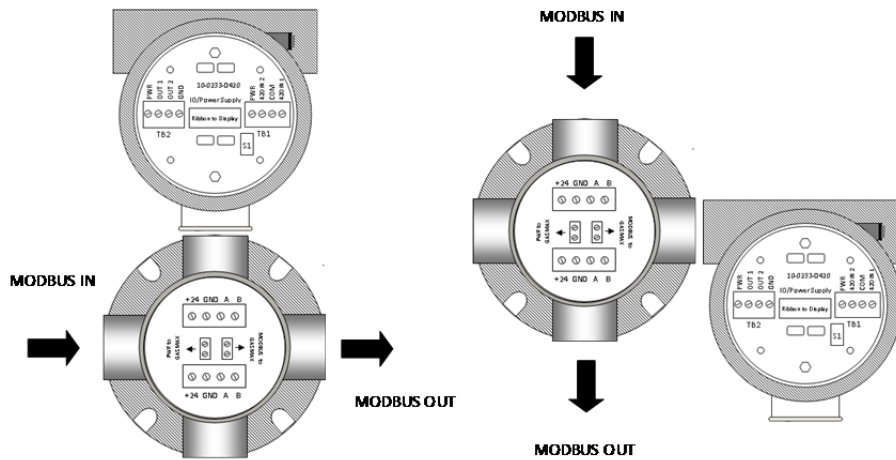

Figure 3-5: MODBUS JBox Installation Options

OPTIONAL DUAL ISOLATED 4-20MA OUTPUT BOARD

The optional 10-0250 Dual Isolated 4-20mA output board provides two dual 4-20mA outputs that are electrically isolated from sensor inputs and the 24 VDC power source. Each 4-20mA output shares the same common ground and are therefore not isolated from each other. This board is connected “piggyback” to the back of the GASMAX II Display Assembly. GASMAX II units may be field upgraded with this option at any time.

NOTE: THE ISOLATED 4-20MA AND MODBUS / RELAY BOARDS SHARE THE SAME CONNECTOR AND THEREFORE CANNOT BE INSTALLED AT THE SAME TIME.

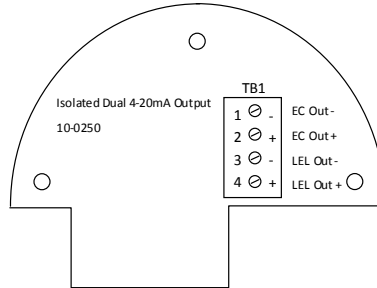

Figure 3-6: Optional Dual Isolated 4-20mA Output

LOCAL SMART TOXIC SENSOR WIRING (CH1)

Local toxic sensors are factory installed in a sensor head directly attached to the GASMAX II enclosure. Local toxic sensors are always connected to the Channel 1 Smart Sensor connector "S1" located on the **back of the Display Assembly** (See Fig.4-5).

IMPORTANT: TOXIC SENSORS MAY FAIL TO OPERATE PROPERLY IF POWER IS NOT APPLIED WITHIN 6 MONTHS OF SHIPMENT. CONTACT GDS CORP FOR RECOMMENDATIONS IF THIS SITUATION MAY OCCUR.

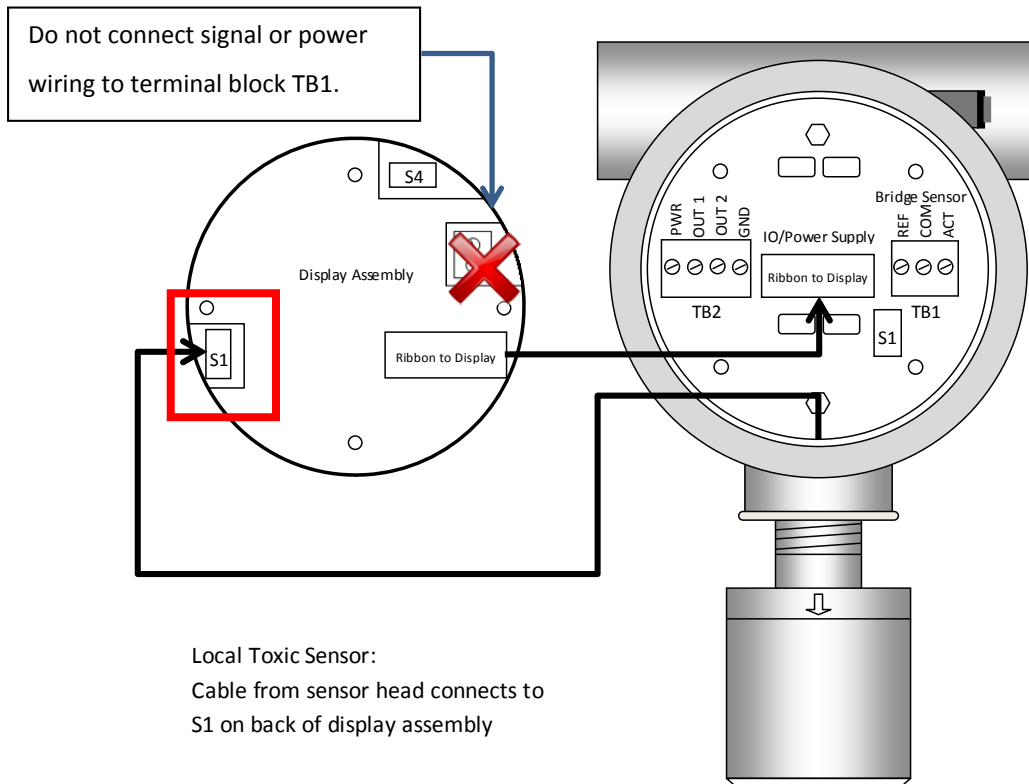

Figure 3-7: Local Smart Toxic Sensor Connection

REMOTE DIRECT TOXIC SENSOR WIRING (CH1)

GASMAX II monitors with remote-mount toxic sensors are shipped in two pieces and sensor wiring must be installed by the end user. Remote toxic sensors connect to the Channel 1 Simple Sensor input on the **back of the Display Assembly** as shown in Figure 4-6.

Due to the small signal output from toxic sensors, remote direct input toxic sensors should be mounted **no more than 15 wire-feet** from the GASMAX II display. Further, the cable used should be **three-wire stranded with foil shield** and should be **run inside metallic rigid conduit**. GDS Corp recommends Belden B8771. The cable shield must be connected to an earth ground at **ONE END ONLY**.

NOTE: Poured seals and rigid conduit are required if the remote sensor is installed in a hazardous area.

IMPORTANT: TOXIC SENSORS MAY FAIL TO OPERATE PROPERLY IF POWER IS NOT APPLIED WITHIN 6 MONTHS OF SHIPMENT. CONTACT GDS CORP FOR RECOMMENDATIONS IF THIS SITUATION MAY OCCUR.

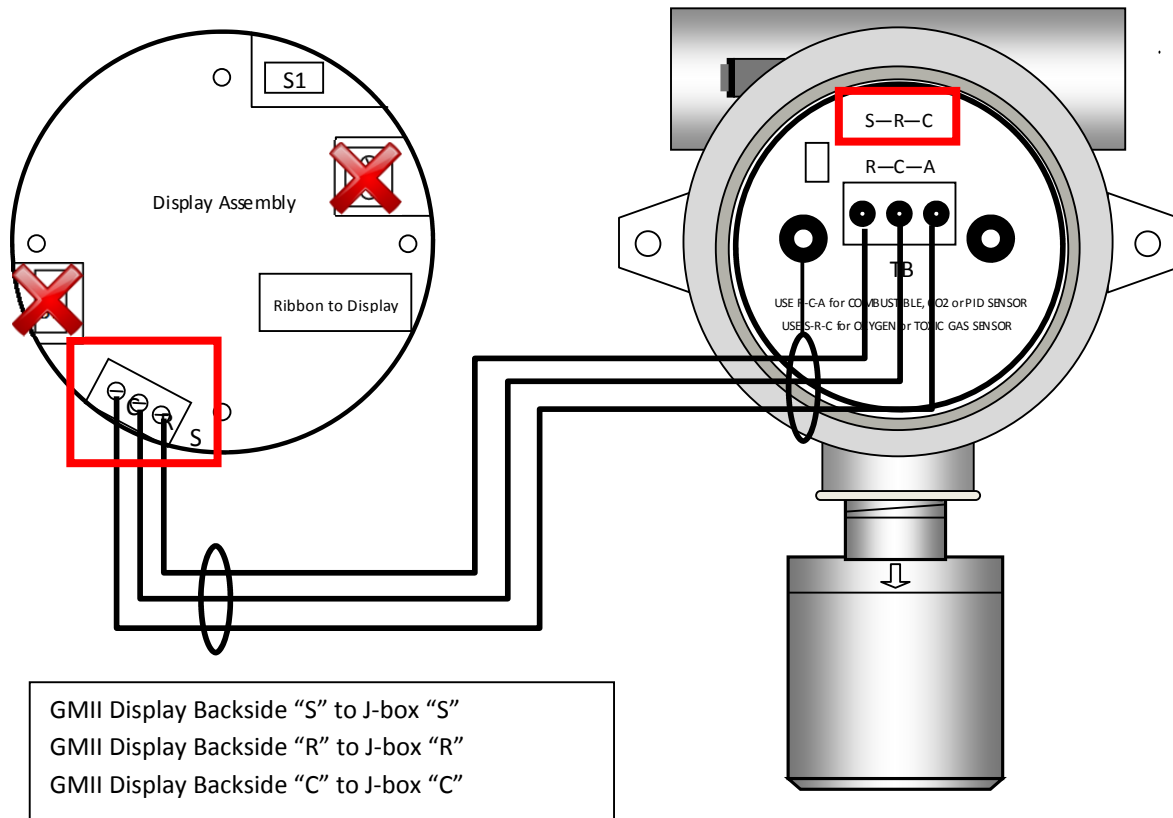

Figure 3-8: Remote Toxic Sensor Connection

REMOTE TOXIC SENSOR TRANSMITTER WIRING (CH1)

GASMAX II monitors with remote-mount toxic sensor transmitters are shipped in two pieces and sensor wiring must be installed by the end user. When used with Channel 1, toxic sensor transmitters connect to the Channel One 4-20mA input on the right-hand side terminal strip of the I/O power supply board.

If the 10-0233-D4 dual 4-20ma input I/O power supply board is installed in the GASMAX II then the remote sensor transmitter is connected as shown below (+24V is available on TB1 pin 1).

IMPORTANT: TOXIC SENSORS MAY FAIL TO OPERATE PROPERLY IF POWER IS NOT APPLIED WITHIN 6 MONTHS OF SHIPMENT. CONTACT GDS CORP FOR RECOMMENDATIONS IF THIS SITUATION MAY OCCUR.

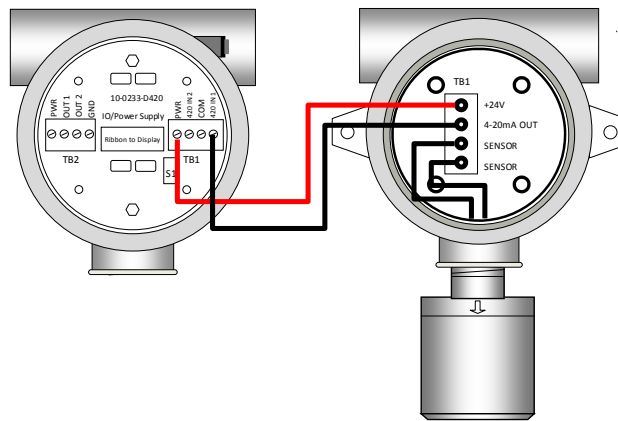

Figure 3-9: Channel 1 Remote Toxic Sensor Transmitter (10-0233-D4)

If the 10-0233-B4 bridge + 4-20ma input I/O power supply board is installed in the GASMAX II then the remote sensor transmitter is connected as shown below (+24V is not available on TB1 pin 1).

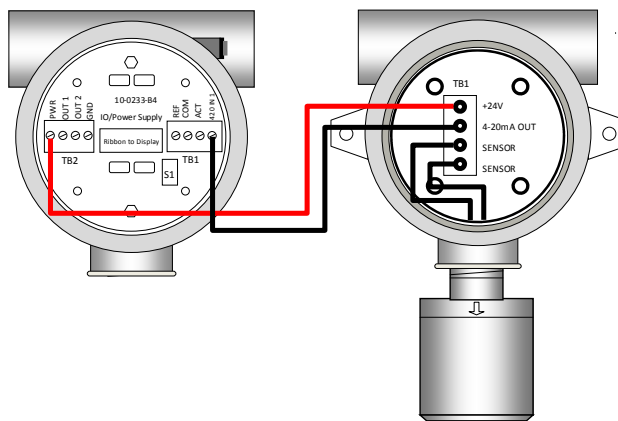
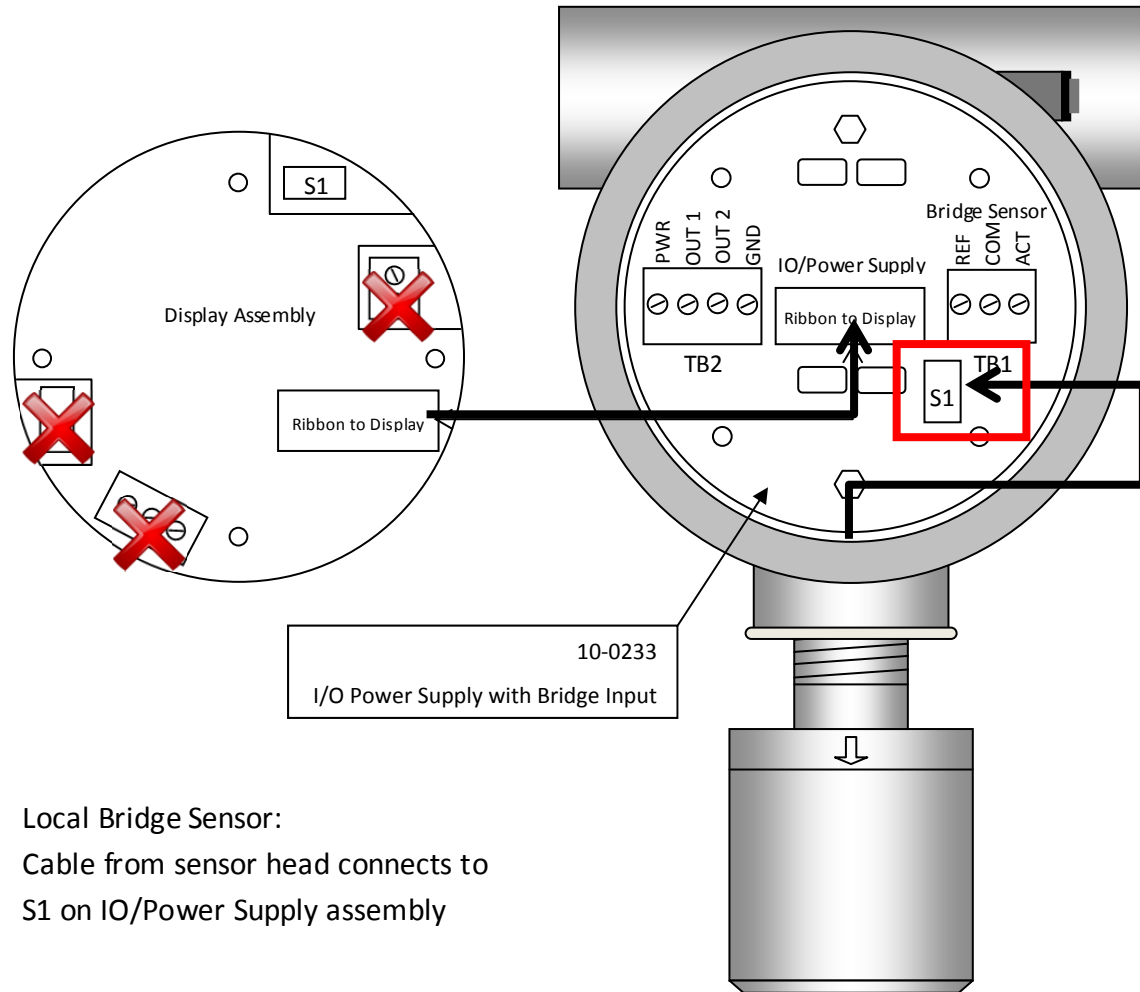

Figure 3-10: Channel 1 Remote Toxic Sensor Transmitter (10-0233-B4)

LOCAL COMBUSTIBLE SENSOR WIRING (CH2)

Local bridge-type sensors, including catalytic bead or infrared sensors for combustibles and photoionization detectors (PID) for volatile organic compounds are factory installed and always connected to the Channel 2 Smart Sensor connector "S1" on the IO/Power Supply board, located on the back of the explosion proof enclosure (See Fig. 4-7).

NOTE: LOCAL SMART BRIDGE SENSORS AUTOMATICALLY ADJUST SENSOR EXCITATION VOLTAGE.



Local Bridge Sensor:
Cable from sensor head connects to
S1 on IO/Power Supply assembly

Figure 3-11: Local Smart Bridge Sensor Connection

REMOTE COMBUSTIBLE SENSOR WIRING (CH 2)

GASMAX II monitors with remote-mount bridge-type sensors are shipped in two pieces and sensor wiring must be installed by the end user. Bridge-type sensors have a more robust output and can be mounted up to 100 feet from the GASMAX II. Cable used should be **three-wire stranded with foil shield** and should be **run inside metallic rigid conduit where possible**. GDS Corp recommends Belden B8771. The cable shield must be connected to an earth ground at ONE END ONLY. Remote bridge sensors connect to "TB1" on the IO/Power Supply board, located on the back of the explosion proof enclosure (See Fig 4-8).

NOTE: Poured seals and rigid conduit are required if the remote sensor is installed in a hazardous area.

WARNING: REMOTE BRIDGE SENSORS DO NOT AUTOMATICALLY ADJUST SENSOR EXCITATION VOLTAGE. IF SWITCHING SENSOR **TYPES**, BE SURE TO ADJUST SENSOR VOLTAGE BEFORE INSTALLING A NEW SENSOR.

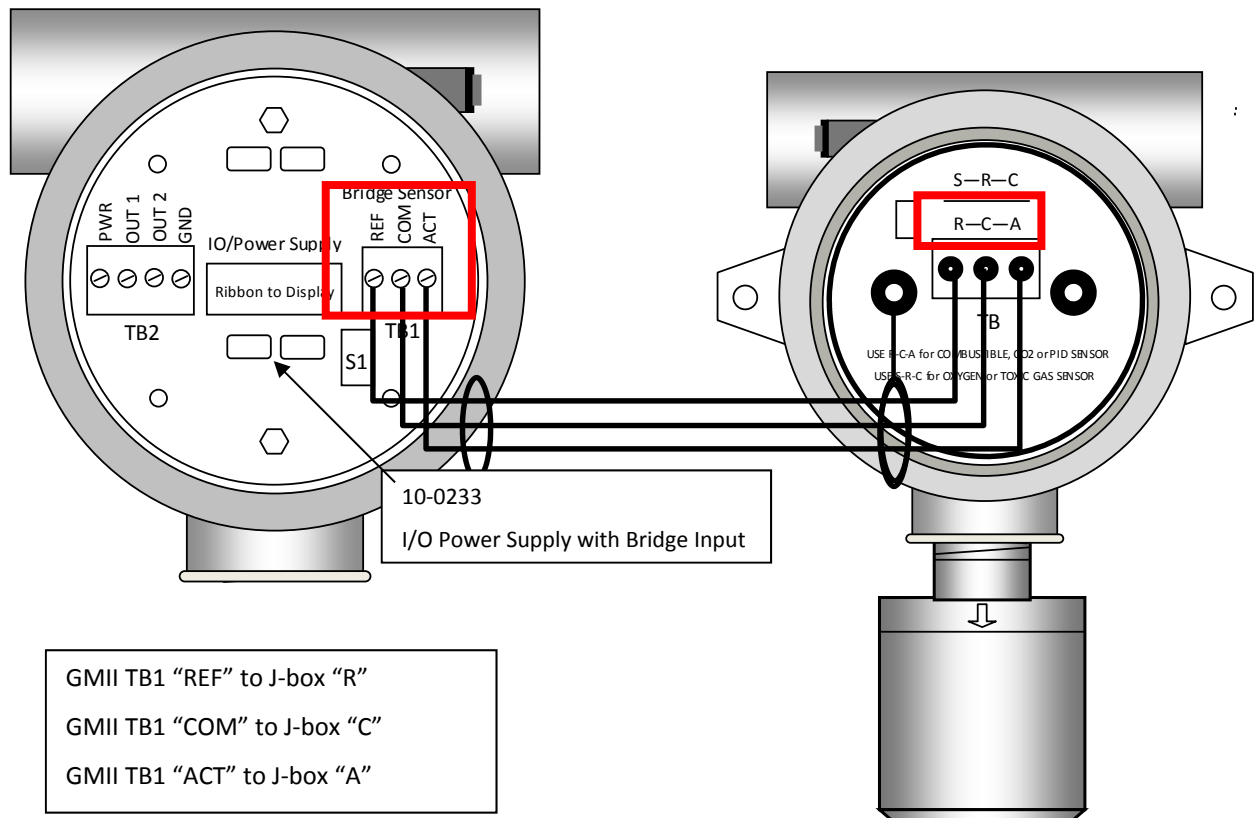

Figure 3-12: Remote Bridge Sensor Connection

REMOTE TOXIC SENSOR TRANSMITTER WIRING (CH 2)

GASMAX II monitors with remote-mount toxic sensor transmitters are shipped in two pieces and sensor wiring must be installed by the end user. When used with Channel 2, toxic sensor transmitters connect to the Channel Two 4-20mA input on the right-hand side terminal strip of the I/O power supply board.

The 10-0233-420 I/O power supply board must be configured for 4-20mA input as shown below.

NOTE: Poured seals and rigid conduit are required if the remote sensor is installed in a hazardous area.

IMPORTANT: TOXIC SENSORS MAY FAIL TO OPERATE PROPERLY IF POWER IS NOT APPLIED WITHIN 6 MONTHS OF SHIPMENT. CONTACT GDS CORP FOR RECOMMENDATIONS IF THIS SITUATION MAY OCCUR.

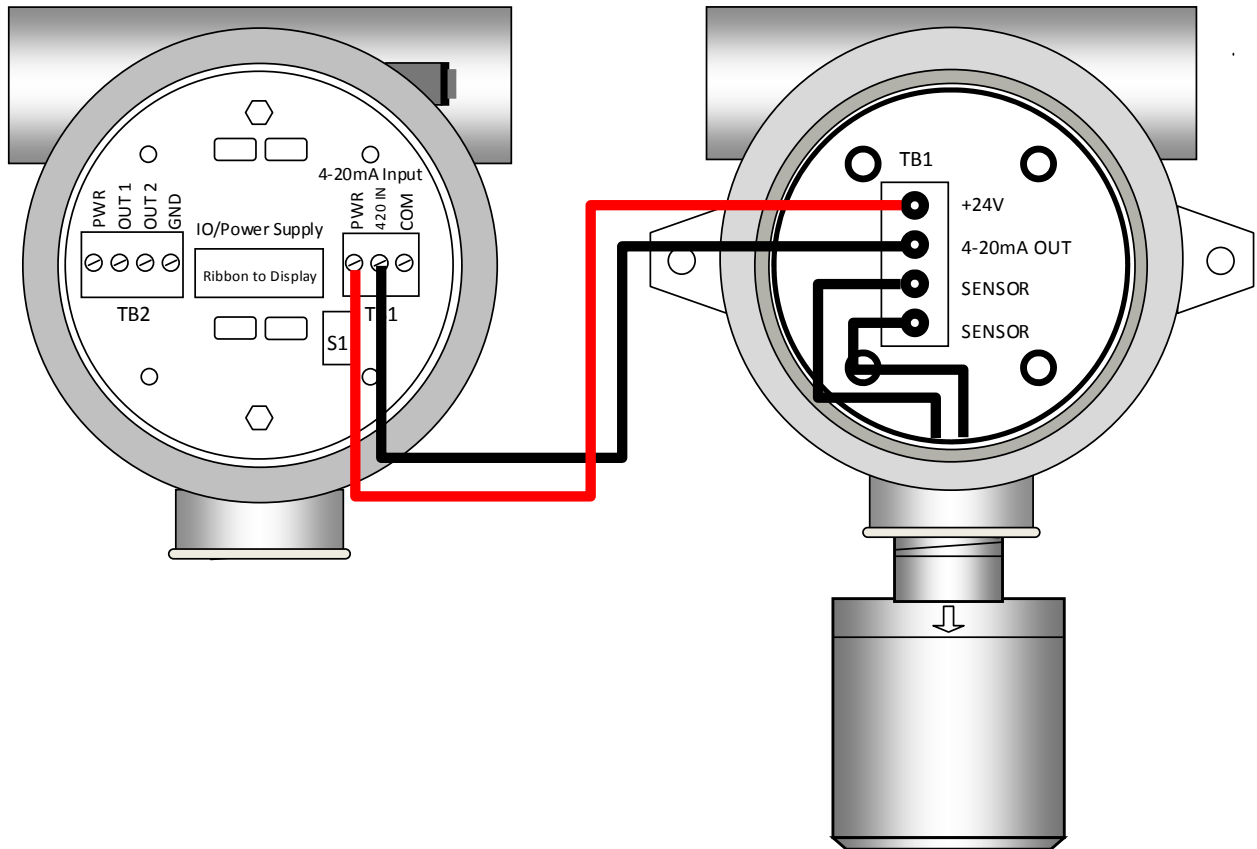

Figure 3-13: Remote Sensor Transmitter Connection

CONNECTING AN EXTERNAL 4-20MA INPUT DEVICE (CH 2)

The GASMAX II can be factory configured to support a general purpose, non-isolated 4-20mA input on channel 2. Power Supply boards that have been converted to 4-20mA will have TB1 marked to indicate PWR (+24V), 4-20 IN (signal) and COM (ground). The amount of voltage and current available for the remote 4-20mA device is determined by the GASMAX DC supply connected to TB2. Note that in this case, channel 1 is still available to support a local or remote toxic sensor. The calibrated output for channel 2 is available on TB2, Pin 3.

NOTE: Poured seals and rigid conduit are required if the remote sensor is installed in a hazardous area.

WARNING: IO / POWER SUPPLY BOARDS THAT HAVE BEEN CONVERTED TO 4-20MA WILL NOT SUPPORT LOCAL OR REMOTE BRIDGE-TYPE SENSORS. ATTACHING A BRIDGE-TYPE SENSOR WILL DAMAGE OR DESTROY THE SENSOR.

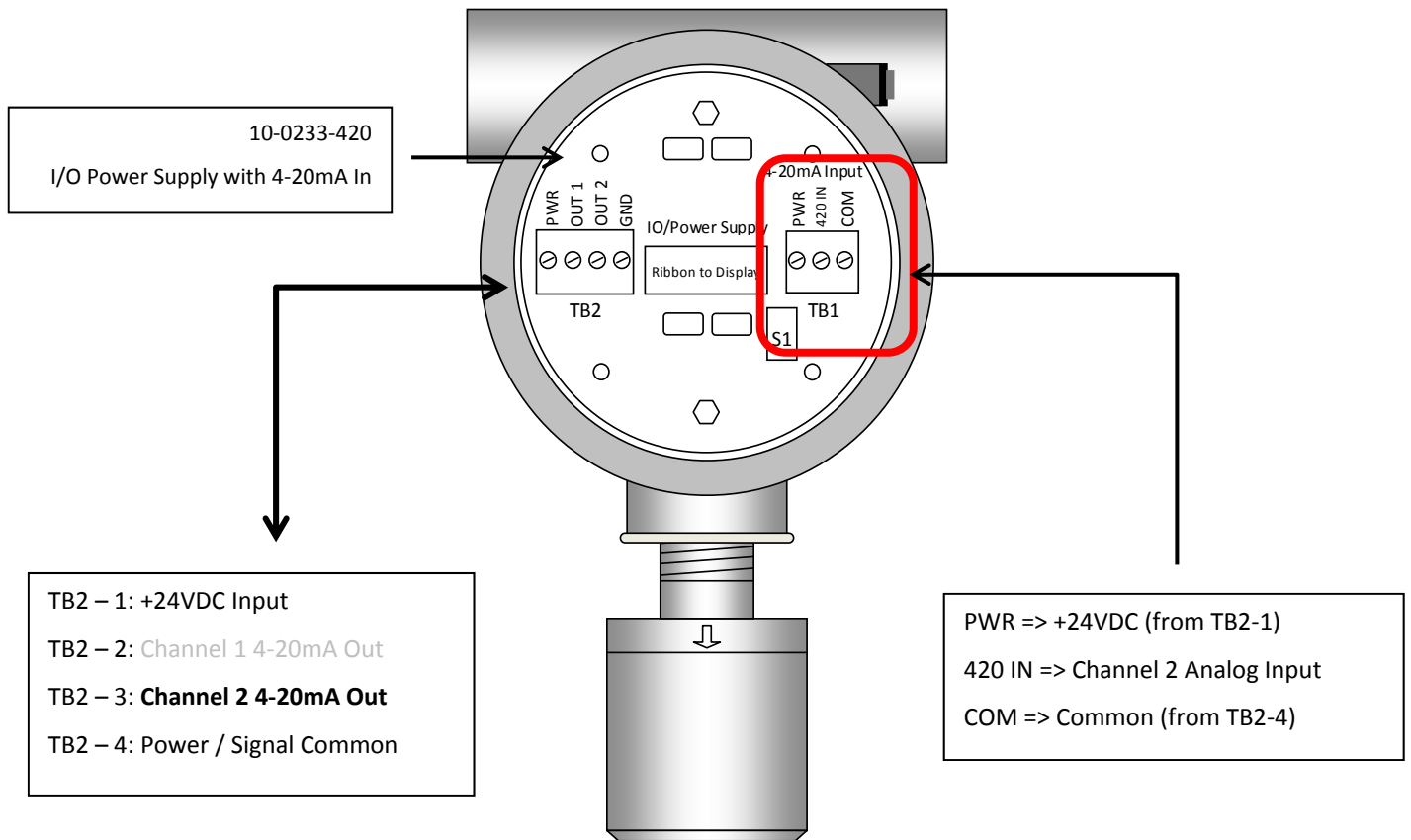

Figure 3-14: Remote 4-20mA Input (Ch 2)

GASMAX DUAL 4-20MA OR 4-20MA + BRIDGE INPUT OPTION

The GASMAX II can be factory configured to support two general purpose, non-isolated 4-20mA inputs on channels 1 and 2 (10-0233-D4), or one non-isolated 4-20mA input on Channel 1 and one BRIDGE input on Channel 2 (10-0233-B4). Power Supply boards designed for dual 4-20mA inputs will have TB1 marked to indicate PWR (+24V), 4-20 IN 2 (signal), COM (ground) and 4-20 IN 1 (signal). The amount of voltage and current available for the remote 4-20mA device is determined by the GASMAX DC supply connected to TB2.

WARNING: DO NOT CONNECT A BRIDGE SENSOR TO TB1 IF THE INPUT HAS BEEN CONFIGURED FOR 4-20MA. THE +24V EXCITATION VOLTAGE WILL DESTROY THE BRIDGE SENSOR.

The most common usage for dual 4-20mA inputs is for use with local or remote GDS-IR Infrared Combustible Sensors or GDS-49 Remote Toxic Sensor Transmitters.

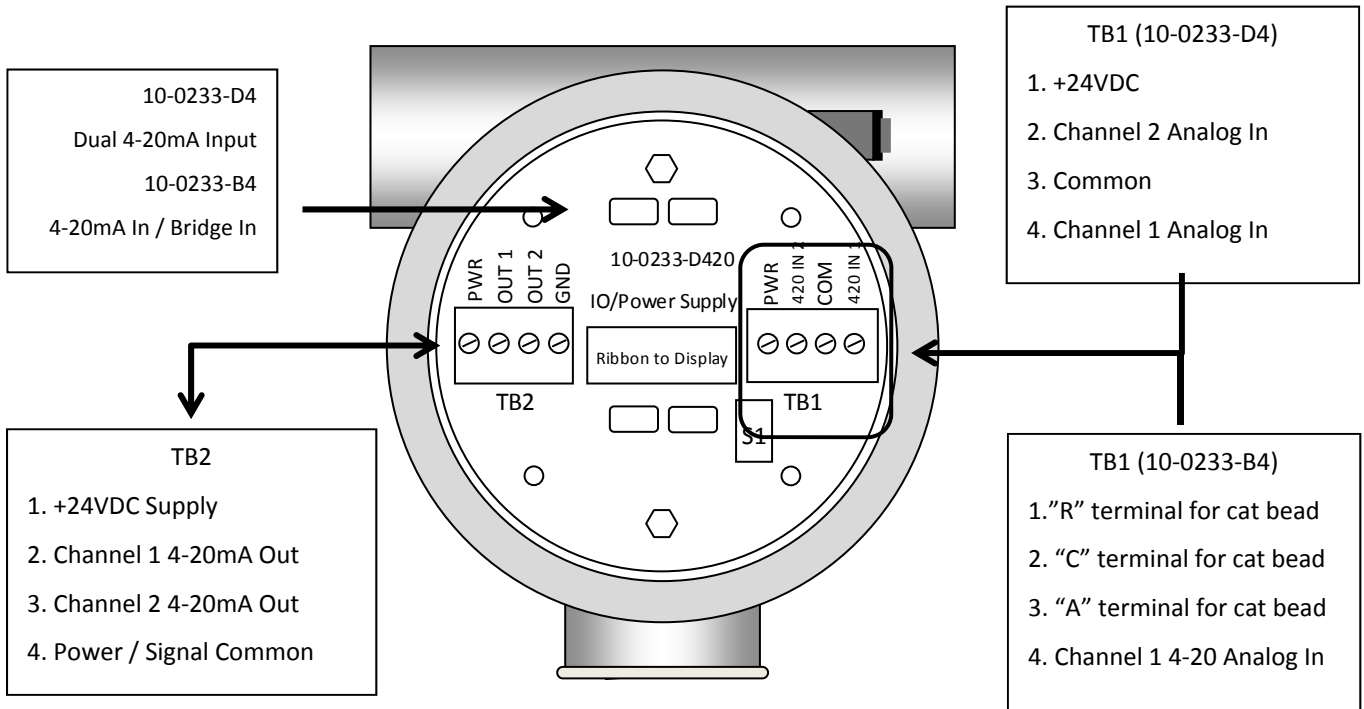

Figure 3-15: Dual 4-20mA Input Option

4 INITIAL SETUP

When power is applied to the GASMAX II, the screen will show 'GASMAX II' followed by one or two Smart Sensor information screens if the sensor(s) are locally connected. Certain sensors may initially indicate off-scale high or low values, but should quickly return to zero within a few minutes if no target gas is present. During this warm-up delay period, the 4-20mA output is held at 4.0 mA to eliminate false alarms in any receiving devices.

GASMAX USER INTERFACE

The GASMAX II display is shown in Figure 5-1. There are four magnetic switches on the face of the GASMAX II, arranged in a quadrant around the LCD display; these are labeled NEXT, EDIT, DOWN/CAL and UP. To activate, or "press" a magnetic switch, swipe the magnetic wand near the switch. For the balance of this manual, the term "press" will be used to describe activation of any key via the magnetic wand.

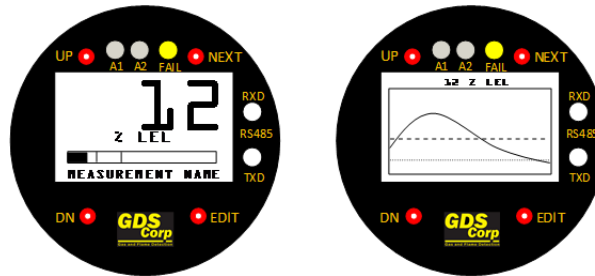

Figure 4-1: Gasmax Single Channel Display

Pressing the NEXT key causes the GASMAX display to switch display screens. In single channel mode, the display will switch between DATA and TREND. In dual channel systems, the sequence will be: DATA 1, DATA 2, TREND 1, TREND 2, DUAL CHANNEL, followed by DATA 1.

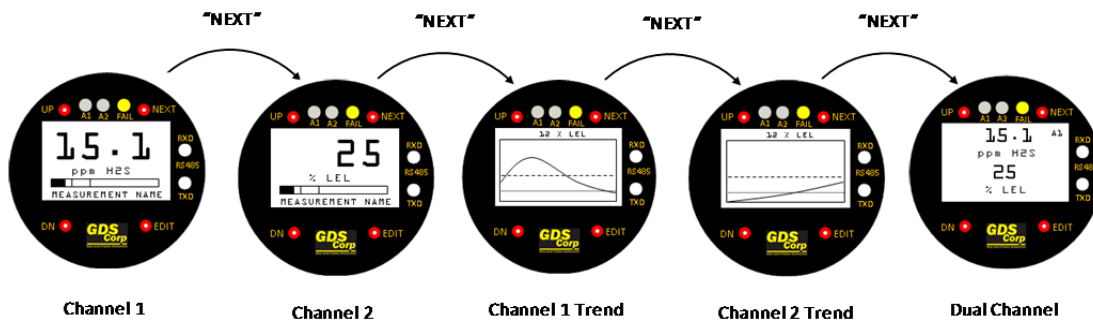

Figure 4-2: Gasmax Dual Channel Display

Press the **EDIT** key to access the **USER MENU** display mode. When in user menu display mode, use UP and DOWN to select an item, EDIT to change an item, and NEXT to exit the menu or function and return the GASMAX II to display mode. See Chapter 8 for more information on User Menus.

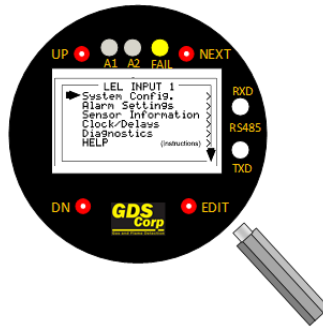

Figure 4-3: User Menu Screen

NOTE: TAKE CARE WHEN CHANGING GASMAX MENU SETTINGS – INCORRECT SETTINGS COULD CAUSE THE GASMAX TO BECOME INOPERATIVE AND MAY COMPROMISE THE SAFETY OF THE GAS DETECTION SYSTEM. BE SURE TO UNDERSTAND WHAT TO CHANGE AND WHY BEFORE ENTERING THE USER MENU.

Press the **DN/CAL** key, followed by the **EDIT** key, to access **CALIBRATION MODE**. Regular calibration is critically important to the continued safe operation of any gas detection system. See Chapter 6 for more information on calibration.

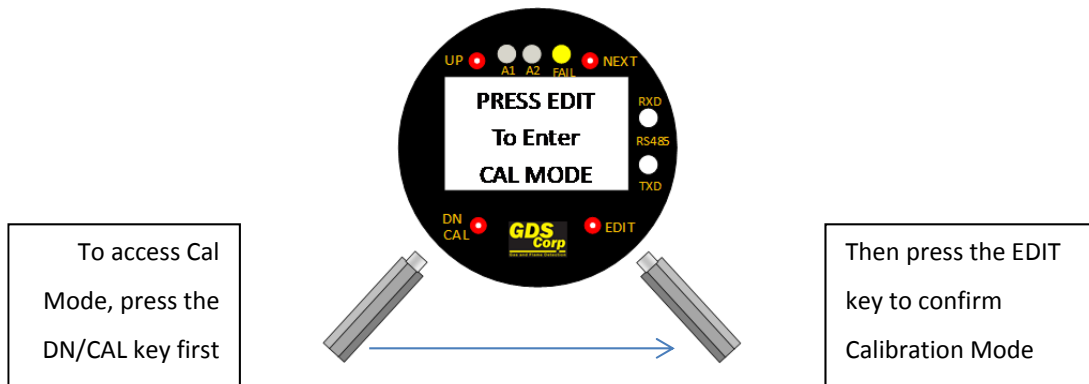

Figure 4-4: Accessing Cal Mode

NOTE: TAKE CARE WHEN APPLYING CALIBRATION GAS TO THE GASMAX WHILE NOT IN CALIBRATION MODE. THIS WILL CAUSE AN INCREASE IN THE 4-20MA OUTPUT SIGNAL AND MAY RESULT IN UNINTENDED AND UNEXPECTED ALARM CONDITIONS.

MORE INFORMATION ON DISPLAY SCREENS

The DATA display screen shows a single channel's information. The current value is shown in calibrated engineering units. A horizontal bargraph tracks the current value and shows the Alarm 1 and Alarm 2 values in graphical form. The user-programmable Engineering Units ("Eunits") and Measurement Name text strings are shown below the real-time reading.

Above the LCD display, three LEDs indicate the status of the level and fault alarms. If relays are installed, the LEDs indicate whether the relays are active. Note that if any relay is set for FAILSAFE operation, if LED is ON the relay will be de-energized. In dual channel mode, if either channel is in alarm the corresponding A1 or A2 indicator LED (and relay) will be energized.

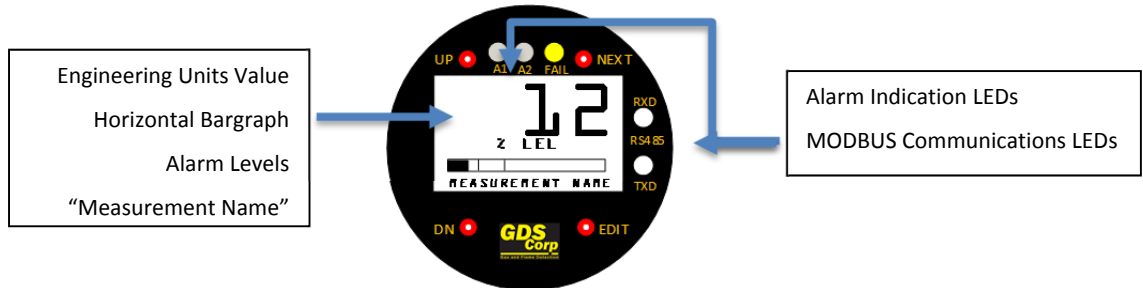

Figure 4-5: GASMAX Data Display

Two LEDs monitor the MODBUS RS-485 transmit (TXD) and receive (RXD) buffers. Flashing indicates sent or received data. RXD will flash whenever a message from the MODBUS master is received and TXD will flash when any response message is transmitted from the GASMAX.

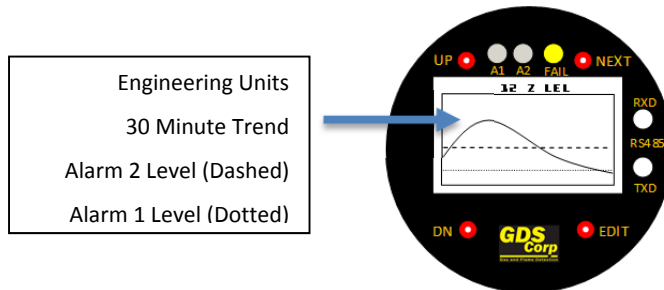

Figure 4-6: GASMAX Trend Display

The TREND screen displays a graph with the last 30 minutes of live readings. The EUNITS value is shown at the top and Alarm 1 and Alarm 2 levels are shown as dotted (A1) and dashed (A2) lines.

TOXIC SENSOR SETUP

Toxic sensors need few adjustments but require time to stabilize properly before they can be calibrated and made operational.

Local Smart Toxic Sensors: The GASMAX II automatically loads all necessary setup information from locally connected toxic sensors via the 10-pin sensor cable. No user setup is required. Initial field calibration is always required.

Remote Direct Toxic Sensors: GASMAX II units with remote direct toxic sensors do not automatically load sensor settings, but when ordered with remote toxic sensors the GASMAX II is pre-configured, calibrated and tested at the factory. No user setup is required. Initial field calibration is always required.

Remote Toxic Sensor Transmitters: GASMAX II units with remote 4-20mA toxic sensor transmitters do not automatically load sensor settings, but when ordered with remote toxic sensor transmitters the GASMAX II is pre-configured, calibrated and tested at the factory. No user setup is required. Initial field calibration is always required.

IMPORTANT: TOXIC SENSORS MAY FAIL TO OPERATE PROPERLY IF POWER IS NOT APPLIED WITHIN 6 MONTHS OF SHIPMENT. CONTACT GDS CORP FOR RECOMMENDATIONS IF THIS SITUATION MAY OCCUR.

BRIDGE SENSOR SETUP

Bridge sensors require a very specific excitation voltage and must be balanced prior to operation.

Local Smart Bridge Sensors: The GASMAX II automatically loads all necessary setup information from locally connected bridge sensors via the 10-pin sensor cable. Voltage adjustment is not necessary, but Balance adjustment may be required due to changes in the sensor that may have occurred during shipping and storage (See Balance adjustment procedure below).

Remote Bridge Sensors: GASMAX II units with remote bridge sensors do not automatically load sensor settings. Remote bridge sensors require both Voltage and Balance adjustment prior to operation.

BRIDGE SENSOR "VOLTS" ADJUSTMENT

Bridge sensors require specific excitation voltages to operate properly. See table below for recommended operating voltages for catalytic bead, SmartIR infrared and PID sensors.

Sensor Type	Excitation Voltage	Expected Current	Recommended Warmup
Catalytic Bead ("7x")	2.0 ± 5%	300 mA	3 hrs
SmartIR (Type "5x")	4.5 ± 10%	85 mA	1 hr
PID (Type "6x")	3.3 ± 5%	35 mA	12 hrs

To adjust sensor excitation voltage, do the following:

1. Access the Channel 2 Technicians Menu on the GASMAX (See User Menus)
2. Select Set Voltage menu item.
3. If the sensor is LOCAL, use the UP and DOWN keys to set the voltage to the proper value. No sensor cable length compensation is required.

4. If the sensor is REMOTE, the sensor voltage MUST BE MEASURED AT THE SENSOR, not at the GASMAX II to compensate for the voltage drop in the intervening wiring. Connect a voltmeter across the sensor "R" and "A" connections and have an assistant use the UP and DOWN keys to set the voltage to the proper value.

WARNING: EXCEEDING THE EXCITATION VOLTAGE WILL DAMAGE OR DESTROY THE SENSOR.

WARNING: IF YOU ARE NOT CERTAIN THAT SENSOR VOLTAGE IS ADJUSTED PROPERLY, FIRST DISCONNECT THE REMOTE SENSOR BEFORE APPLYING POWER TO THE GASMAX II. SECOND, APPLY POWER AND ADJUST THE EXCITATION VOLTAGE AT THE SENSOR JUNCTION BOX TO THE TARGET VALUE. FINJALLY, RECONNECT THE REMOTE SENSOR AND INCREASE THE SENSOR VOLTAGE TO COMPENSATE FOR VOLTAGE DROP IN THE INTERVENING CABLE.

BRIDGE SENSOR "BALANCE" ADJUSTMENT

Bridge sensor output for a zero reading is a fixed voltage that varies from sensor to sensor. The Balance setting allows the GASMAX II to adjust its internal reference to match the sensor's zero set point.

To adjust sensor balance, do the following:

1. Access the Technicians Menu on the GASMAX (See User Menus)
2. Select Set Balance menu item.
3. Use the Up and DOWN keys to adjust the displayed reading to zero. (Note: a reading of "0" corresponds to a counts value of 512).

NOTE: BRIDGE SENSORS DRIFT DURING WARMUP AND REQUIRE TIME TO STABILIZE. ALWAYS ALLOW AT LEAST ONE FULL HOUR BETWEEN POWER-UP AND FINAL BALANCE ADJUSTMENT.

NOTE: MAKE SURE NO TARGET GAS IS PRESENT WHEN ADJUSTING BALANCE.

PROGRAMMING ALARM SETTINGS

GASMAX II gas monitors have front panel LED indicators for ALARM 1 and ALARM 2. Both alarm indicators can be set to activate above or below a given engineering units set point. Alarm processing will trigger an alarm condition when the input exceeds the programmed value, and includes hysteresis to keep the alarm from rapidly switching ON and OFF if the input remains close to the programmed alarm value.

NOTE: ALARM RELAYS ARE NORMALLY TRIGGERED IF EITHER CHANNEL 1 OR CHANNEL 2 ALARM THRESHOLDS ARE EXCEEDED.

NOTE: IF THE OPTIONAL ALARM RELAYS ARE NOT INSTALLED, ALARM SETTINGS AFFECT THE OPERATION OF THE FRONT PANEL LEDS ONLY. SEPARATE ALARM SETTINGS MAY NEED TO BE PROGRAMMED IN THE 4-20MA RECEIVING DEVICE.

ALARM OPERATION – ALARM 3

ALARM 3 is typically used to indicate FAULT conditions that suggest sensor failure or “out of measurement range” conditions. However, some applications require a third level alarm. The ALARM 3 menu is identical to ALARM 1 and ALARM 2 and may be set to trip at any level.

NOTE: ALARM 3 WILL ALSO TRIP WITH MISSING OR FAILED SENSORS REGARDLESS OF THE PROGRAMMED LEVEL VALUE.

FINAL TRANSMITTER SETUP

Once operational, the user should verify the following transmitter settings prior to initial calibration. Setting these values during warm-up is recommended.

1. Local time and date: Check date value and adjust time for proper time zone.
2. Tag name or Engineering Units settings: Edit values as necessary.
3. CAL SPAN GAS value: Set to match concentration of calibration gas cylinder.
4. CAL MARKER value: Adjust desired output mA during calibration.
5. ALARM 1, ALARM 2 settings: Set for desired levels. NOTE: If relays are not installed, GASMAX II programmable alarm levels affect operation of front panel LEDs only.

A NOTE ON WARM UP

Allow the GASMAX II to stabilize for at least four hours, preferably overnight if possible. This will allow all sensors to reach stable equilibrium with respect to environmental conditions such as ambient temperature, humidity, and barometric pressure. Infrared sensors generally contain intelligent electronics that compensate for atmospheric conditions; these sensors can be considered ‘ready’ in as little as one hour. Electrochemical sensors depend on chemical processes that need more time to reach equilibrium with the applied “reference” and “counter” voltages generated by the GASMAX II electronics.

Once warm-up is complete, the GASMAX II can be calibrated and made operational.

5 CALIBRATION

CALIBRATION OVERVIEW

Calibration is critically important to ensure correct operation of the GASMAX II. The built-in CAL MODE function is designed to make calibration quick, easy and error free; a successful ZERO and SPAN calibration requires only four keystrokes.

During CAL MODE the sensor output is disabled and the GASMAX II transmits a fixed mA value, called the CAL MARKER, to notify the receiving device that a calibration is in progress. During the following CAL PURGE DELAY time, the GASMAX II transmits a fixed 4.0 mA signal to prevent external alarms during calibration. In the case of local or remote Oxygen sensors, during CAL PURGE DELAY the output simulates a typical atmospheric reading of 20.8%. CAL MODE automatically exits if no keystrokes are detected after 5 minutes.

Follow these GASMAX II calibration guidelines:

- Calibration accuracy is only as good as the calibration gas accuracy. GDS Corp calibration gases are traceable to NIST (National Institute of Standards and Technology).
- **Never use calibration gas that has passed its expiration date.**
- Check the SPAN GAS VALUE setting and make sure it matches the calibration gas. (See Fig. 6-2)
- Always use a GDS Corp calibration cup that completely surrounds the sensor head.
- Be sure to use ZERO AIR, a mixture of 21% oxygen and 79% nitrogen, as a zero reference unless you are certain that no target gas exists in the area. Ambient gas may result in an 'elevated zero' condition that will cause a FAULT to occur once the ambient gas is no longer present.
- **Always calibrate a new sensor before depending on the device for personnel or equipment safety**
- Calibrate on a regular schedule. GDS Corp recommends a full calibration every 3 months, with periodic 'bump tests' on a more frequent basis to ensure that the sensor has not been affected by temperature extremes or the presence of incompatible gases.

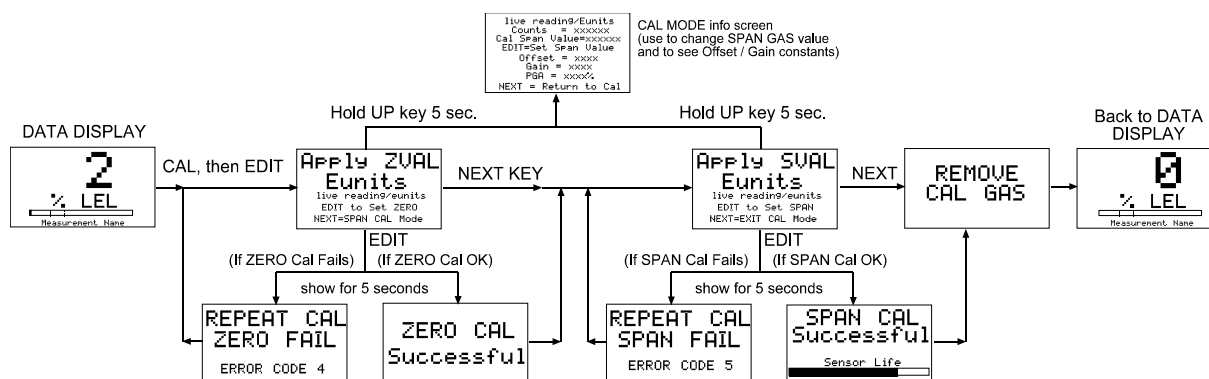
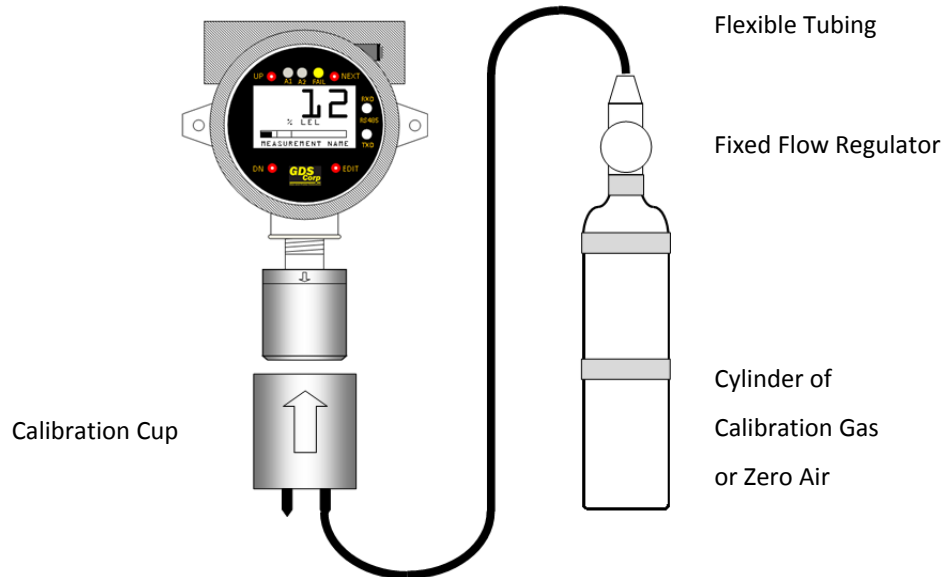

Figure 5-1: Calibration Flowchart

CALIBRATION PROCEDURE

Before beginning calibration, make sure you have the following items: A cylinder of calibration gas, fixed flow regulator and an appropriate calibration cup connected to the regulator via a length of flexible tubing. A cylinder of 'zero air' is always recommended and may be necessary if the absence of target gas cannot be confirmed. GDS Corp recommends a flow rate of 0.5 liters / minute for standard gases and a flow rate of 1.0 liters / minute for highly reactive gases such as chlorine or chlorine dioxide.



To calibrate a GASMAX II detector:

1. For dual channel units, press the NEXT key until that the DATA Display for the desired channel is shown.
2. Enter CAL MODE by pressing the DOWN / CAL key and within 5 seconds press the EDIT key.
3. The screen will display an APPLY ZERO message. Using the setup shown in Fig. 5-1, apply clean ZERO air unless it can be guaranteed that no target gas is present. After the reading stabilizes, press the EDIT key to complete the ZERO calibration.
4. If the zero calibration is successful, a ZERO CAL SUCCESSFUL message is displayed, followed by an APPLY SPAN message.
5. Disconnect the zero air cylinder and connect the span gas cylinder and apply the SPAN gas After the reading is stable, (approximately 1 minute, could be as long as 2-3 minutes) press the EDIT key to complete the SPAN GAS calibration. If the SPAN calibration is successful, the display flashes SPAN CAL SUCCESSFUL followed by REMOVE CAL GAS.
6. Immediately shut off the regulator and remove the calibration cup. At the end of the CAL PURGE delay, the GASMAX II output is re-enabled and the unit is fully operational.

NOTE: A CAL MODE INFO SCREEN IS AVAILABLE TO VIEW CERTAIN CAL MODE PARAMETERS DURING CALIBRATION. HOLD THE UP KEY FOR 5 SECONDS DURING CAL MODE TO DISPLAY THIS SCREEN.

6 MAINTENANCE

NORMAL MAINTENANCE

Normal maintenance for the GASMAX II primarily involves periodic inspection of the unit followed by calibration. GDS Corp recommends calibration at least every three to six months, or more often if temperature extremes, vibration, the presence of incompatible gases or other environmental factors may accelerate the deterioration of the sensor element. Calibration is an ideal time to inspect the unit for clogged or wet sensor heads, cracked or damaged enclosures and water incursion inside conduit or junction boxes.

SENSOR REPLACEMENT

If a local toxic sensor shows **FAULT**, does not respond to gas or can no longer be calibrated, it should be replaced. If a remote direct toxic sensor shows **FAULT**, does not respond to gas or can no longer be calibrated, before replacing the sensor check the wiring between the sensor and GASMAX II for electrical continuity. In addition, check for signs of moisture or corrosion in any of the cabling or junction boxes.

To physically replace a GASMAX sensor, perform the following steps:

1. Declassify the area or remove power to the GASMAX II.
2. Unscrew the sensor head cover. If unable to open the cover by hand, use a Sensor Head Replacement Tool (p/n 10-0187).
3. Remove the old sensor by pulling straight down. **DO NOT TRY TO UNSCREW THE SENSOR!**
4. Carefully install the replacement sensor by aligning the arrow on the sensor with the arrow engraved on the sensor head. Push straight up until the sensor connector seats firmly into the sensor connector.
5. Reinstall the sensor head cover by **CAREFULLY** screwing the cover onto the sensor head.

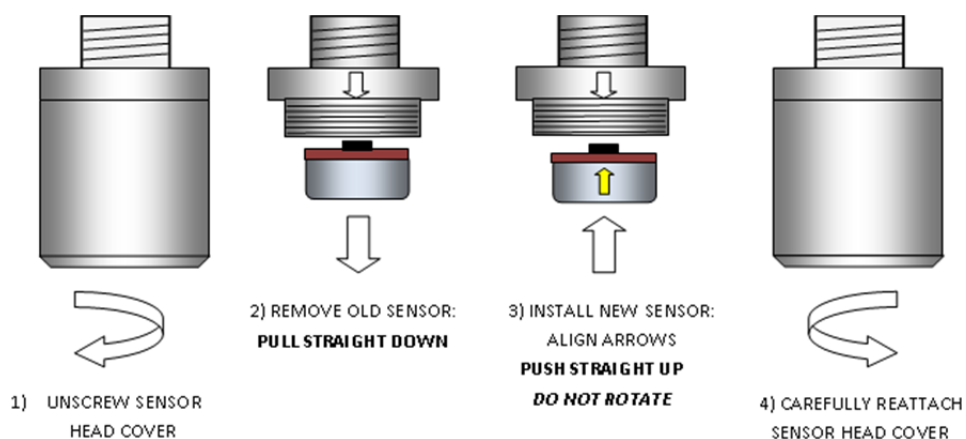

Figure 6-1: GASMAX SENSOR REPLACEMENT

NOTE: IF THE SENSOR FALLS OUT OF THE SOCKET DURING REINSTALLATION, REPLACING THE SENSOR HEAD CAN DESTROY THE SENSOR AND SENSOR HEAD. USE CAUTION WHEN REINSTALLING THE COVER.

SENSOR REPLACEMENT – LOCAL AND DIRECT TOXIC SENSORS

For local or remote direct toxic sensors use GDS Corp type 10-95XX-RYYYY sensors, where “XX” is the gas type and “YYYY” is the full scale range. For example, a replacement H₂S sensor for 0-100 ppm would be part number “10-9515-R0100”.

Local Smart Sensors are automatically recognized by the GASMAX II when installed. If the sensor is the same gas type as was previously installed, the sensor’s calibration data (“Gain” and “Offset”) will be uploaded into the GASMAX II memory. All other parameters stored in the GASMAX II will be retained.

Remote direct toxic sensors are not automatically recognized by the GASMAX II. After installing the sensor, execute the “Install New Sensor” command found on the GASMAX II SENSOR SETUP/INFO menu page. This will erase previous calibration values and reset the Sensor Life value to 100%.

SENSOR REPLACEMENT – REMOTE TOXIC SENSOR TRANSMITTERS

GASMAX II remote toxic sensor transmitters use GDS Corp type 10-90XX-RYYYY toxic sensors, where “XX” is the gas type and “YYYY” is the full scale range. For example, a replacement sensor for a toxic sensor transmitter for 0-100 ppm would be part number “10-9015-R0100”.

SENSOR REPLACEMENT – LOCAL BRIDGE SENSORS

GASMAX II monitors use GDS Corp type 10-95XX-RYYYY bridge sensors, where “XX” is the sensor type and “YYYY” is the full scale range. For example, a replacement catalytic bead sensor for 0-100% LEL methane would be part number “10-9570-R0100”.

Local Smart Sensors are automatically recognized by the GASMAX II when installed. If the sensor is the same gas type as was previously installed, the sensor’s calibration data (“Gain” and “Offset”) will be uploaded into the GASMAX II memory. All other parameters stored in the GASMAX II will be retained.

Although the sensor balance value is uploaded from the sensor during initialization, GDS Corp recommends a Balance adjustment prior to full operation.

SENSOR REPLACEMENT – REMOTE BRIDGE SENSORS

GASMAX II monitors use GDS Corp type 10-95XX-RYYYY bridge sensors, where “XX” is the gas type and “YYYY” is the full scale range. For example, a replacement catalytic bead sensor for 0-100% LEL methane would be part number “10-9570-R0100”.

Remote bridge sensors are not automatically recognized by the GASMAX II. After installing the sensor, execute the “Install New Sensor” command found on the GASMAX II SENSOR SETUP/INFO menu page. This will erase previous calibration values and reset the Sensor Life value to 100%.

When replaced, bridge sensor excitation Voltage should be checked to ensure it is within required tolerance. After allowing time for warm-up, the bridge sensor Balance adjustment should be performed prior to calibration.

7 USER MENUS

MAIN MENU

GASMAX II setup variables are stored in non-volatile memory and can be modified by the end user to better match a particular application. The GASMAX II Main Menu tree is shown below. To access the Main Menu, swipe the magnetic wand over the EDIT key.

Pressing EDIT from either data display enters the LEL or EC SETUP PAGE 1 menu.

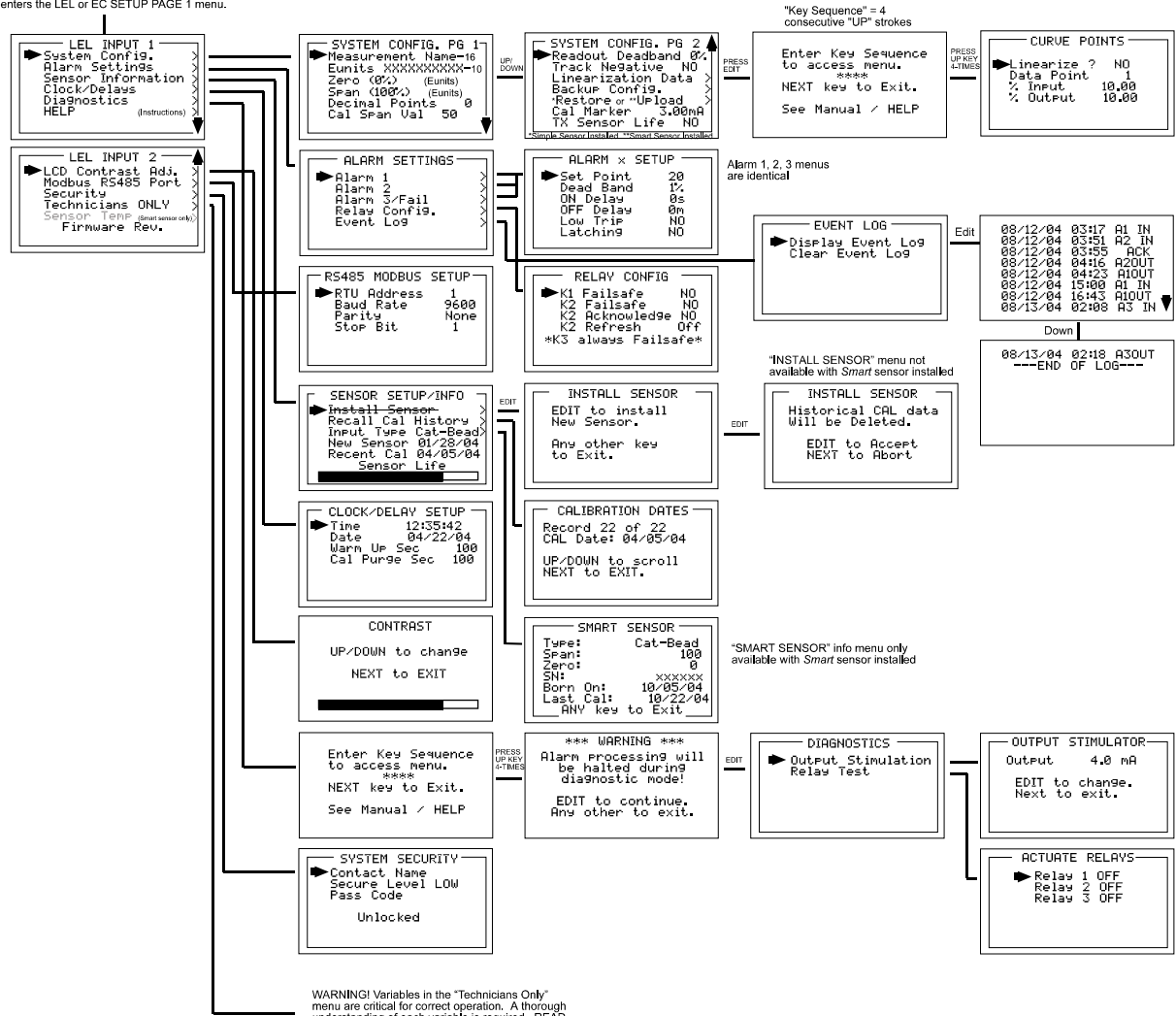

WARNING! Variables in the "Technicians Only" menu are critical for correct operation. A thorough understanding of each variable is required. READ & UNDERSTAND THE MANUAL! "Technicians Only" menus discussed in Section 6.

Figure 7-1: Main Menu Flowchart

SYSTEM CONFIGURATION PAGE

The System Config group consists of two pages of menus as shown in Figure 6-2. Each item's description follows in this section.

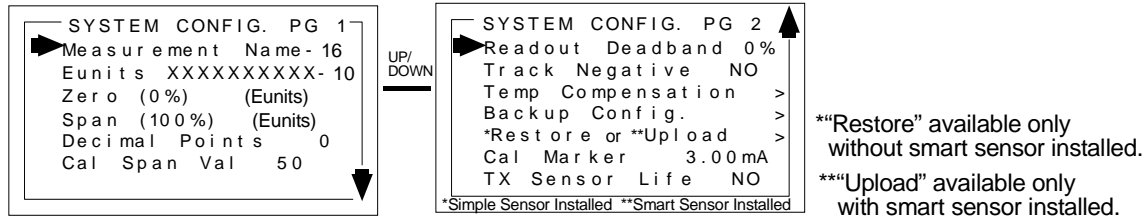

Figure 7-2: System Config Menu

MEASUREMENT NAME may be edited to contain virtually any 16-character field and is typically used to describe the monitored point by user tag number or other familiar terminology. To modify the existing setting, press the EDIT key when the cursor is pointing to the entry. Use the UP or DN keys to change the character, and the NEXT key to move to the next character. Press EDIT again when done.

EUNITS (engineering units) may have up to a 10 character ASCII field. Many common gases have pre-configured Eunits based upon the sensor type and each may be edited in this menu as described in Configuration Using the Magnetic Wand section 5-2.

ZERO (0%) defines the reading to be displayed when 4mA (0%) is the GASMAX II output.

SPAN (100%) defines the reading to be displayed when 20mA (100%) is the GASMAX II output. The highest reading allowed is 9999 including negative polarity sign. Polarity is only indicated for negative readings.

DECIMAL POINTS set the resolution of the LCD readings and may be set for 0, 1 or 2. For example, ZERO readings for 0, 1 & 2 decimal points displays as “0”, “0.0” & “0.00”.

CAL SPAN VALUE sets the engineering units value of the calibration gas. GDS Corp recommends that the calibration gas value be between 25% and 75% of full scale. Calibrating at 100% of scale is not recommended.

READOUT DEADBAND forces low values to continue to read zero. This is useful when there are small amounts of background gases that may cause fluctuating readouts. The highest amount of deadband allowed is 5%.

NOTE: THE 4-20MA OUTPUT IS NOT AFFECTED BY THIS SETTING.

TRACK NEGATIVE allows the display to show negative values when set to “YES”. This can be helpful when troubleshooting sensor problems. The default setting is “NO” and forces the display to read “0” if the sensor value drops below zero. However, negative sensor outputs will always cause the Fault alarm to trip. The 4-20mA output always locks at 4mA when the reading drifts negative.

TEMP COMPENSATION adjusts sensor output based on ambient temperature. GDS Corp temperature compensated sensors are preprogrammed with the necessary table of values and are automatically uploaded to the GASMAX II from the smart sensor. This menu item is not accessible unless a temperature compensated local Smart Sng is installed.

BACKUP CONFIG allows users to store the entire current GASMAX II menu database into non-volatile memory for restoration later if incorrect values are accidentally entered or uploaded.

RESTORE CONFIG restores the GASMAX II menu database to the values from the most recent Backup Config. This menu item is only available if a smart sensor is not installed. The special keystroke sequence of 4 consecutive UP keys is also required to perform backup and restore operations.

UPLOAD SENSOR DATA allows the user to manually upload the entire smart sensor database to the GASMAX II from the smart sensor.

CAL MARKER allows the user to set the 4-20mA output value that is transmitted during ZERO and SPAN calibration. This setting is limited to between 2ma and 20mA and is a useful way to indicate to a GDS controller that the unit is in CAL MODE.

TX SENSOR LIFE causes the GASMAX II 4-20mA output to transmit a “sensor life” value after the completion of a successful calibration cycle. During normal operation, the GASMAX II transmits a 4mA signal during the CAL PURGE delay to allow time for the span gas to dissipate. With TX Sensor Life = YES, the GASMAX II transmits 4mA for the first 10 seconds, then for 5 seconds transmits a value between 4mA and 5mA, with 4mA equal to 0% sensor life and 5mA equal to 100% sensor life (see Figure 5-5). The output then returns to 4mA for the remainder of the CAL PURGE delay. For example, if after a calibration sensor life is 75%, the GASMAX II transmits 4.75mA during the 5-second interval

NOTE: TX SENSOR LIFE SHOULD ALWAYS BE SET FOR NO UNLESS THE 4-20MA RECEIVER IS CAPABLE OF INTERPRETING THE SENSOR LIFE SIGNAL. MOST GDS CORP PROTECTOR SERIES CONTROLLERS INCLUDE THIS CAPABILITY.

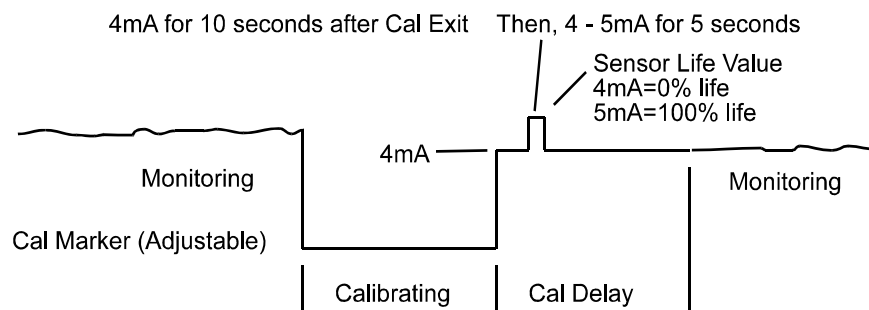

Figure 7-3: Sensor Life Transmission Format

ALARM SETTINGS PAGE

The Alarm Settings page covers the Alarm 1, 2, 3 Setup and Event Log menu items. Alarm 1, Alarm 2 and Alarm 3/Fail menus are identical and are therefore described only once. If the optional alarm relays are not installed, the alarm settings only affect the operation of the front panel LEDs. In that case, separate alarm settings may need to be programmed in the 4-20mA receiving device.

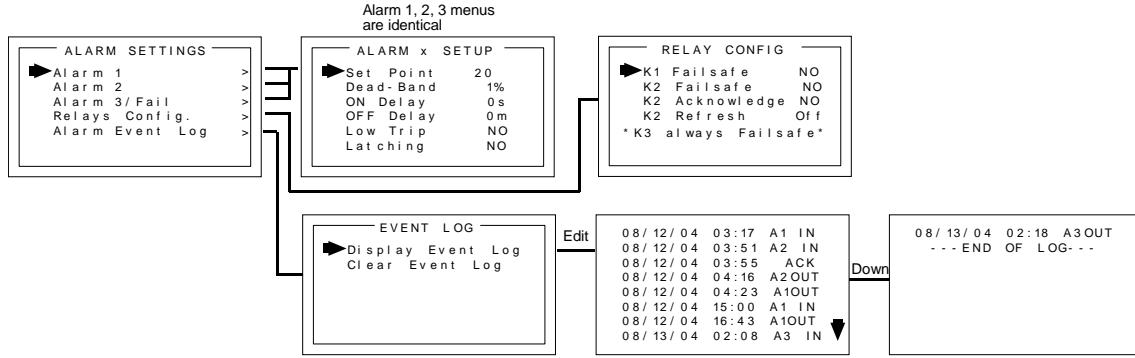

Figure 7-4: Alarm Settings Menu

SET POINT enters the engineering unit value where the alarm trips. It may be negative and trip when monitored values fall out of range in this direction. A3 has a default setting of negative 10 with Low Trip set for YES. This makes it function as a FAULT alarm and trip when the monitored value falls below “-10”. It is important to adjust this value when the transmitter’s span value is set for another value other than 100. For example, a typical span setting for monitoring oxygen level is 0-25.0(%), therefore the fault level value should be adjusted to -2.5 which is equivalent to negative 10% of full scale.

DEAD-BAND has a minimum value of 1% and a maximum value of 10%. It is useful for preventing alarm cycling when the monitored value is hovering around the set point.

EXAMPLE: With a range of 0-100 ppm, if Dead-Band equals 5% and the set point is 20 ppm, after tripping at 20 ppm the value must drop below 15 ppm to reset.

ON DELAY allows entering a maximum 10 second delay before this alarm becomes active. This is useful for preventing nuisance alarms caused by brief spikes beyond the set point.

OFF DELAY allows entering a maximum 120 minute delay before clearing an alarm after the alarm condition is gone. This is useful for continuing an alarm function, such as operation of an exhaust fan, for a period of time after the alarm condition clears.

LOW TRIP set to YES causes the alarm to trip as the value falls below the set point.

LATCHING set to YES causes the alarm to remain active even after the condition is gone and only reset when the UP / RESET key is pressed from a data display.

DISPLAY EVENT LOG displays the stored events in the Event Log. These include power-on, cold-boot, alarms and alarm acknowledge events. The event log stores the date and time of the most recent 300 events.

CLEAR EVENT LOG clears the event log.

RS-485 COMMUNICATIONS

The RS-485 MODBUS SETUP menu allows setting the RTU address (if RS-485 equipped) for each GASMAX on the RS-485 network. Each GASMAX must have a different RTU address when communicating on the same 2-wire cable RS-485 loop. Baud rate, Parity and Stop Bit are fixed at industry standard values of 9600 baud, No Parity and One Stop Bit.

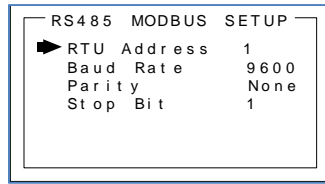

Figure 7-5: RS-485 MODBUS Menu

SENSOR SETUP

The Sensor Information page covers settings associated with Smart or simple sensors. Users can review information contained in the Smart Sensor database, or adjust settings for remote simple sensors.

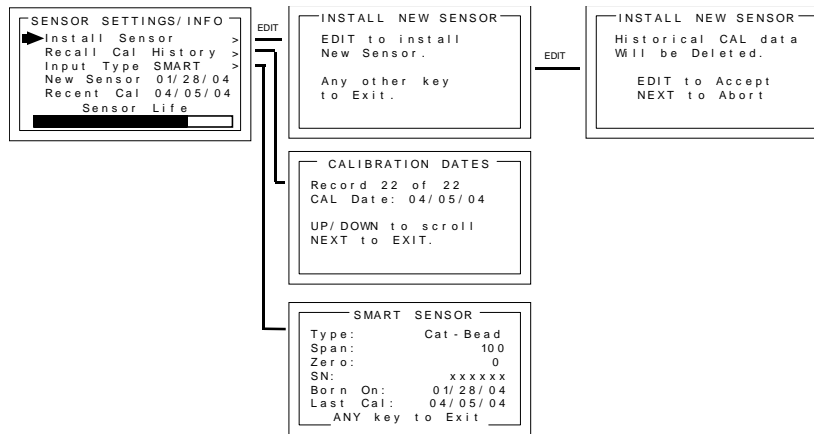

Figure 7-6: Sensor Settings Menu

INSTALL NEW SENSOR should always be performed when a new simple sensor is installed. This deletes historical CAL data and sets sensor life to 100% after initial calibration of the new simple sensor. The GASMAX II Smart Sensor interface will automatically detect new Smart Sensors and this menu is therefore not available with a Smart Sensor connected.

RECALL CAL HISTORY recalls each successful calibration. These dates may be reviewed by scrolling with the UP / DOWN keys.

INPUT TYPE indicates what kind of input or sensor the GASMAX II is configured to accept and is typically pre-configured at the factory. When installed, Smart Sensors upload sensor type and other data to the GASMAX II and this data may be viewed on the SMART SENSOR information screen.

NEW SENSOR displays the date when a new sensor was last installed.

RECENT CAL displays the most recent calibration date.

CLOCK / DELAY SETUP PAGE

The GASMAX II is equipped with a crystal-controlled, battery-backed real-time clock that maintains local Time and Date. These values are factory preset to US Central Time and should be reset to correctly match the current time zone during installation to make sure that time-stamped Event Log entries are correct.

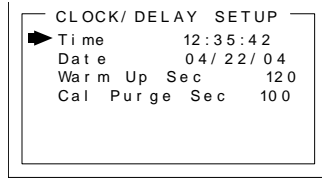

Figure 7-7: Clock Delay Menu

TIME adjusts time of day in hours, minutes and seconds.

DATE adjusts date in month, day, year.

WARM UP DELAY sets the amount of time from power-on until the 4-20mA output signal begins to track the sensor output. Default setting is 60 seconds. Maximum value is 255 seconds.

CAL PURGE DELAY sets the amount of time from the completion of span calibration until the 4-20mA output signal restarts tracking the sensor output. The default setting is 60 seconds and the maximum value is 255 seconds.

LCD CONTRAST ADJUSTMENT PAGE

The LCD Contrast Adjustment allows the display to be set for optimum viewing.

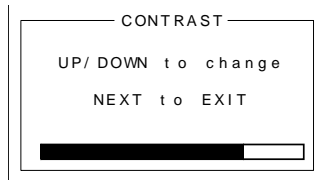

Figure 7-8: Contrast Menu

HELP SCREEN PAGE

The Help screen contains several pages of information describing GASMAX II operation.

DIAGNOSTICS PAGE

The Diagnostics page provides tools for use during setup or testing. Since relays are not available on the GASMAX II, the Relay Test option is not functional.

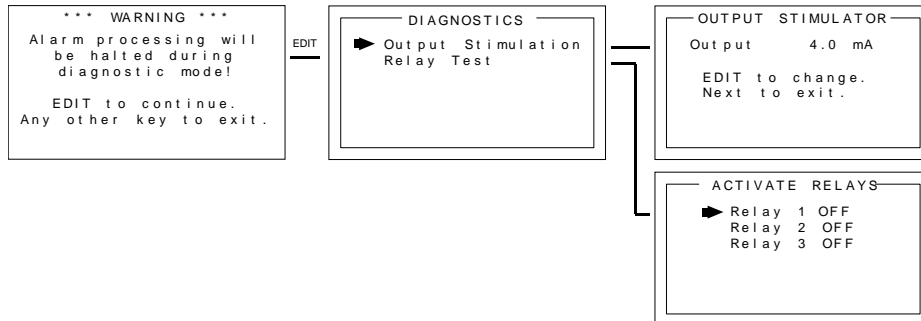

Figure 7-9: Diagnostics Menu

OUTPUT SIMULATION allows setting the 4-20mA output to virtually any desired value. This is useful for checking responses of devices receiving the GASMAX II's 4-20mA output.

RELAY TEST allows the user to manually activate any of alarm relays independent of the presence of gas. This is useful during troubleshooting or initial installation when an end-to-end test of relay functionality must be done.

WARNING: TARGET GAS MONITORING AND ALARM PROCESSING ARE NOT ACTIVE WHILE IN THIS MENU.

SYSTEM SECURITY PAGE

The System Security menu offers two levels of protection against operation by unauthorized personnel or those with malicious intent.

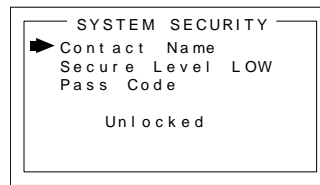

Figure 7-10: System Security Menu

CONTACT NAME is a 12 character ASCII field available for displaying a phone # or name of personal who knows the Pass Code. Lost Pass Codes may be recovered by entering the locked security menu and holding the UP key for 5 seconds. The 4-digit code appears near the bottom of the screen.

SECURE LEVEL sets LOW, HIGH or OFF modes. A LOW level allows CAL MODE sensor calibrations but requires the 4-digit Pass Code prior to altering menus. HIGH level locks the entire menu database and the CAL Mode until the correct Pass Code is entered. LOW and HIGH security levels always allow static viewing of configuration menus.

TECHNICIANS MENU GROUP

The TECHNICIANS MENU group consists of the XMITTER CONFIG menu and TECHNICAL PAGE menu. These menus contain items that are typically factory configured depending upon the type sensor and input connected. Care should be used when modifying these variables as some items will prevent proper operation and could endanger personnel.

Access requires a special key sequence of four UP keystrokes to prevent accidental modification of critical items.

XMITTER CONFIG MENU

The XMITTER CONFIG menu is used to activate channels, precisely calibrate 4-20mA outputs and set time / date. To access the XMITTER CONFIG menu, press and hold the NEXT key for 5-seconds until the screen appears requesting the special key sequence.

WARNING: TARGET GAS MONITORING AND ALARM PROCESSING ARE NOT ACTIVE WHILE IN THIS MENU.

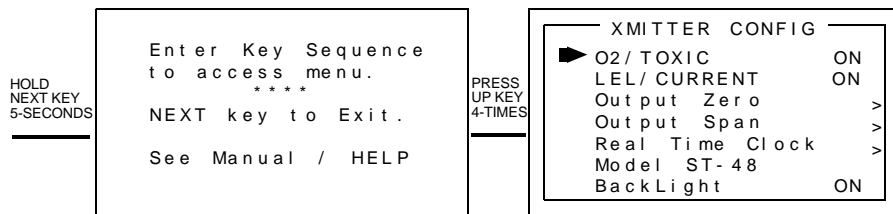

Figure 7-11: Xmitter Config Menu

O2 / TOXIC when set to YES enables the Oxygen / Toxic channel (Channel 1).

LEL / CURRENT when set to YES enables the LEL / Current channel (Channel 2).

OUTPUT ZERO / SPAN TRIM provides a way to precisely set the GASMAX II 4mA and 20mA outputs to compensate for variation in output components. These settings are programmed at the factory and should not be modified.

REAL TIME CLOCK adjusts the date and time for use in EVENT LOGGING. The current time and date can also be adjusted from the Main Menu (See Section 7).

MODEL is factory set and should not be modified.

BACKLIGHT is not available in the GASMAX EC two-wire loop powered transmitter.

TECHNICAL PAGE MENU

The TECHNICAL PAGE menu is used to adjust certain parameters associated with local or remote sensors. To access the TECHNICAL PAGE menu, enter the Main Menu, move the cursor to the second page and select Technicians Only. Enter the key sequence (four “UP” keys) to activate the TECHNICAL PAGE menu.

WARNING: TARGET GAS MONITORING AND ALARM PROCESSING ARE NOT ACTIVE WHILE IN THIS MENU.

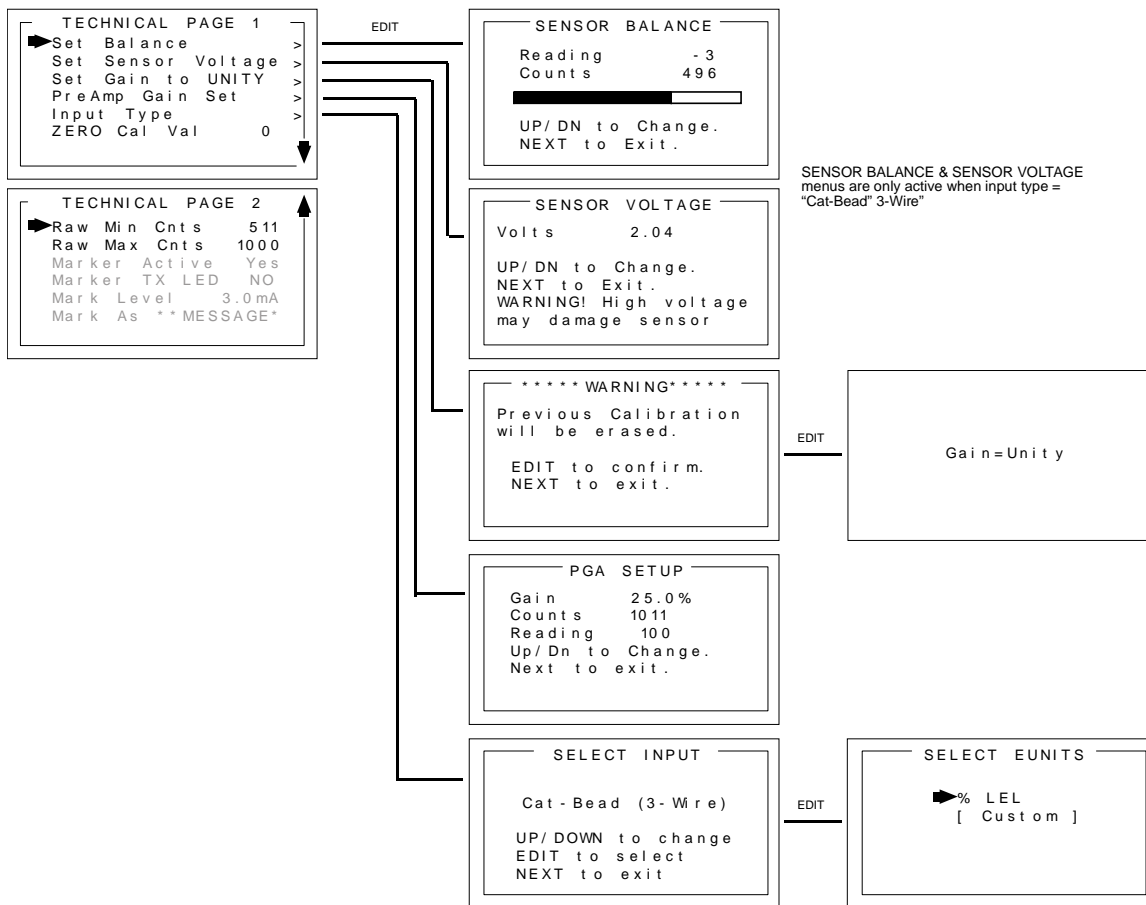

Figure 7-12: Technical Page Menu

SET BALANCE adjusts the balance of a bridge-type sensor and must only be performed with ZERO gas on the sensor. Balance is similar to a very coarse ZERO calibration and does not need to be precise since subsequent calibrations will correct for small errors. ZERO gas applied to the sensor should provide a Reading of -3 to +3 on the SENSOR BALANCE menu.

SET VOLTAGE adjusts the excitation voltage applied to bridge type sensors and may vary from 2 to 6 volts. Local Smart Sensors automatically adjust the excitation voltage to match the needs of the sensor. Remote sensors require manual adjustment. Excitation voltage must be measured **at the sensor**; therefore, if the sensor is mounted some distance away from the GASMAX II, the excitation voltage may have to be higher to compensate for losses in field wiring.

WARNING: EXCEEDING A SENSOR'S RATED EXCITATION VOLTAGE MAY DAMAGE OR DESTROY THE SENSOR.

SENSOR BALANCE & SENSOR VOLTAGE
menus are only active when input type =
"Cat-Bead" 3-Wire"

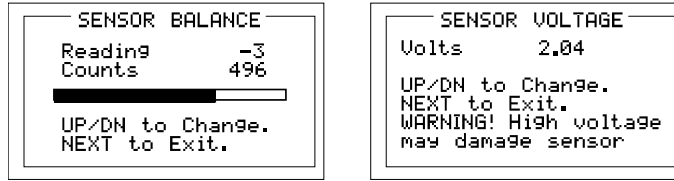

Figure 7-13: Sensor Balance & Voltage Set Menu

SET GAIN TO UNITY clears any previous calibration OFFSET and GAIN values to “0.0” and “1.0”, respectively. This item is useful if a previous calibration was done in error, or if screen readings appear incorrect for no apparent reason.

WARNING: A FULL CALIBRATION SHOULD ALWAYS BE PERFORMED AFTER A SET UNITY COMMAND.

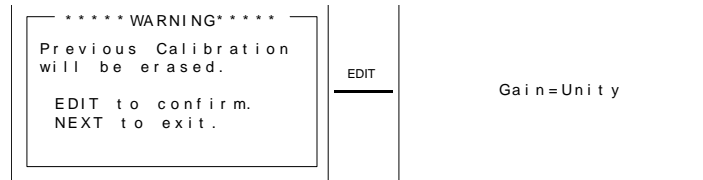

Figure 7-14: Set Gain To Unity Menu

PREAMP GAIN SET allows adjustment of the analog amplifiers that match the sensor output to the optimum input range for the GASMAX II signal conditioning circuits. Local Smart Sensors include factory-preset preamp gain values and for standard sensors and applications, these values should not be changed. For remote simple sensors or for situations where a local Smart Sensor does not quite provide enough signal to successfully complete a SPAN calibration, the Preamp gain can be adjusted using the UP / DOWN keys. GDS Corp does not recommend adjusting the Preamp Gain to any value higher than 85%.

WARNING: A FULL CALIBRATION SHOULD ALWAYS BE PERFORMED AFTER ANY CHANGE IN THE PREAMP GAIN SETTING.

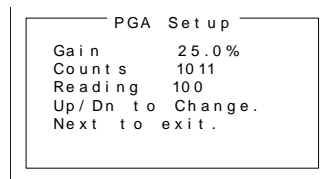

Figure 7-15: Preamp Gain Set Menu

Simple Sensor Input Type Local Smart Sensors automatically configure Input Type to match sensor requirements. However, when using remote sensors, Input Type must be set manually. Input Type is factory preset and should not be changed unless a different TYPE remote sensor is to be installed. Input Type configures GASMAX II hardware to accept bridge sensors, positive coefficient electrochemical sensors, negative coefficient electrochemical sensors or 4-20 mA inputs. After selecting Input Type, a SELECT EUNITS screen indicates the default engineering units for this sensor.

Coefficient	Electrochemical Sensor Type	Default EUNITS
Negative	Hydrogen Sulfide	ppm H2S
Negative	Oxygen	% Oxygen
Negative	Carbon Monoxide	ppm CO
Negative, Bias	Ammonia	ppm NH3
Negative, Bias	Nitric Oxide	ppm NO
Negative	Ethylene Oxide	ppm Eth O2
Negative	Hydrogen Chloride	ppm HCL
Negative	Hydrazine	ppm N2H4
Negative	Arsine	ppm Arsine
Negative	Sulfur Dioxide	ppm SO2
Negative	Hydrogen	ppm H2
Negative	Hydrogen Cyanide	ppm HCN
Negative	Phosgene	ppm COCl2
Negative	Phosphine	ppm PH3
Negative	Hydrogen Fluoride	ppm HF
Positive	Nitrogen Dioxide	ppm NO2
Positive	Ozone	ppm Ozone
Positive	Chlorine	ppm Cl2

ZERO CAL VALUE should always be set to "0".

RAW MIN / MAX COUNTS is factory preset and should not be changed.

MARKER ACTIVE enables an input level monitor on the channel 2 input if the input is set to accept a 4-20mA signal. If Marker Active is set the YES, the following actions may be programmed to occur when the input signal matches the Marker Level setting.

MARKER TX LED will cause the TX LED to illuminate if the 4-20mA input matches the Marker Level setting.

MARK LEVEL is the value at which the Marker is active. The input must be within +/- 1% of this value to be active. Setting is in mA.

MARK AS MESSAGE is a text message string that appears on the LCD when the input level matches the Marker Level setting.

Channel Floating Point	15 bit plus sign 2's complement with +/-5% over / under range applied. Contact GDS Corp for more information.
------------------------	--

8 TROUBLESHOOTING

LOCAL SMART TOXIC SENSOR NOT RECOGNIZED

- If a locally connected toxic sensor is not recognized on power-up or when installed, verify that the sensor cable is plugged in as shown in the section on local toxic sensors and that channel 1 is turned on in the Transmitter config menu.

TOXIC SENSOR INDICATES FAULT OR OVERRANGE

- Certain toxic sensors indicate off-scale low or high at power up and quickly drift towards zero. This is normal behavior.
- Toxic sensors showing constant FAULT: If local, remove sensor and examine for moisture or discoloration. Replace sensor if wet or discolored. If remote, check sensor cable and junction box for moisture or standing water. Remove sensor and examine for moisture or discoloration. FAULT indication generally indicates sensor useful life is exhausted.
- Toxic sensors left unpowered for more than 3 months are subject to accelerated degradation and may demonstrate a permanent loss of sensitivity.

TOXIC SENSOR WILL NOT CALIBRATE

- Sensor reading during zero calibration exceeds upper limit of zero – sensor is defective and should be replaced.
- Sensor reading during span calibration too low – sensor may be defective. However, it may be possible to *temporarily* continue operation by increasing PREAMP GAIN. See Section 8.2 for more details.

LOCAL SMART BRIDGE SENSOR NOT RECOGNIZED

- If a locally connected bridge sensor is not recognized on power-up or when installed, verify that the sensor cable is plugged in as shown in the section on local bridge sensors and that channel 2 is turned on in the Transmitter config menu.

BRIDGE SENSOR INDICATES FAULT OR OVERRANGE

- Catalytic bead combustible sensors generally indicate off-scale high at power up and quickly drift towards zero as they reach operating temperature. This is normal behavior.
- Combustible sensors showing constant FAULT may have drifted below FAULT alarm level. Try readjusting SENSOR BALANCE to clear FAULT. If unsuccessful, replace sensor.
- Combustibles sensors showing constant OVERRANGE may have defective bead. If remote, check wiring for correct excitation voltage at sensor. Replace sensor.

BRIDGE SENSOR WILL NOT CALIBRATE

- Sensor reading during zero calibration exceeds limits – readjust SENSOR BALANCE to reset zero if possible. If not, sensor is defective and should be replaced.
- Sensor reading during span calibration too low – sensor may be defective. However, it may be possible to *temporarily* continue operation by increasing PREAMP GAIN. See Section 8.2 for more details.

RECEIVING DEVICE AND GASMAX DISPLAYED VALUES DON'T MATCH

- Check that zero and full scale range values match between GASMAX and receiving device (controller). Use DIAGNOSTICS menu to force GASMAX II output to 12mA (1/2 scale) and verify appropriate half-scale reading on controller.
- Check for high impedance shorts to ground on 4-20mA wiring.
- If 4-20mA output is off-scale low or high and cannot be adjusted using DIAGNOSTICS mode, IO/Power Supply board may be defective and should be replaced.

CONTROLLER MODBUS DATA INCORRECT

- Verify that MODBUS master is requesting data from correct registers (31001 for channel 1 (toxic), 31002 for channel 2 (combustible)).
- Verify that controller MIN and MAX count settings are correct. MIN counts should be "200" which corresponds to 4mA and MAX counts should be "1000" which corresponds to 20 mA.
- Verify that the GASMAX MODBUS address matches the address programmed into the controller's channel configuration.

CONTROLLER SHOWING MODBUS COMM ERROR

- Check for incorrect MODBUS polarity (swap "A" and "B" if unsure; no damage will occur).
- Verify that MODBUS master is requesting data from correct MODBUS address.
- Verify that MODBUS master is requesting correct registers: 31001 for channel 1 (toxic), 31002 for channel 2 (combustible).
- Verify that there are no other MODBUS slave devices with identical MODBUS address.

GASMAX DISPLAY BLANK

- Verify DC power at IO/Power Supply board, TB2, terminals 1 (+24) and 4 (Gnd).
- Verify ribbon cable connected between IO/Power Supply board and Display Assembly.
- Verify that there are **no** wires connected to the 4-20mA LOOP INPUT on the back of the Display Assembly.

GASMAX ERROR CODES

- 01 – Incorrect sensor type – new sensor does not match most recent type of sensor. This is normal if changing sensor types. If unexpected, verify that new sensor type matches previous sensor type.
- 02 – Zero or span mismatch. Smart sensor zero or span values differ from those stored in the GASMAX.
- 03 – Sensor Calibration Error – Contact factory.
- 04 – Zero calibration failure – Zero readings must be within 10% of zero. For example, if the range is 0-100 ppm, the zero reading cannot be above 10 ppm. For bridge-type sensors, it may be possible to readjust the balance to restore a zero reading. Toxic sensors with high zero readings must be replaced.
- 05 – Span calibration failure – Span readings must be within a range of from ½ to 2x the target value. For example, if the target is 50 ppm, the sensor must output at least 25 ppm and no higher than 100 ppm at the current preamp gain setting for calibration to proceed.
- 06 – History data file full. Clear event log to remove.
- 07 – Sensor Channel Data CRC Fail – Error in sensor data transfer. Contact factory.

- 08 – System Data CRC Fail – Error in system data file. Contact factory.
- 09 – Custom Data CRC Fail – Error in system data file. Contact factory.
- 10- Linearization Data CRC Fail – Error in system data file. Contact factory.

SOFTWARE RESET (“COLD BOOT”)

If the GASMAX display shows ‘nonsense’ characters or one or more of the settings appear to be corrupted, performing a “Cold Boot” will restore the default values in the non-volatile memory and may clear the problem. To perform a ‘Cold Boot”, perform one of the two following procedures:

- Disconnect power. Hold a magnetic wand over the EDIT key and apply 24VDC power. Hold the magnet until the screen shows a “COLD BOOT” message.
- Hold the magnetic wand over the NEXT key until the “Enter code sequence’ appears. Press four “UP” keys to enter the XMITTER menu. Make a change in any value and then restore the value to its original setting. Press the NEXT key to exit and THEN IMMEDIATELY PLACE THE MAGNETIC WAND OVER THE EDIT KEY. Hold the magnet until the screen shows a “COLD BOOT” message.

Note that a COLD BOOT will reset certain values to their default setting, including the MODBUS address value. If a Smart Sensor is connected to a local sensor head, the GASMAX will reload the sensor type, range, cal span value and other sensor –related values automatically.

9 MODBUS INTERFACE

The GASMAX II features a full complement of user-accessible MODBUS registers that can provide a complete snapshot of each gas detectors configuration. This includes all real-time data, preset zero, span and calibration values and user-programmable text.

Variable Name	Alias	Read FC	Write FC	Notes
Ch 1 Alarm 1	2001	2	N/A	Modbus Coils (read only)
Ch 1 Alarm 2	2002	2	N/A	
Ch 1 Fault	2003	2	N/A	
Ch 2 Alarm 1	2004	2	N/A	
Ch 2 Alarm 2	2005	2	N/A	
Ch 2 Fault	2006	2	N/A	
K1 (Relay 1)	2007	2	N/A	
K2 (Relay 2)	2008	2	N/A	
K3 (Relay 3)	2009	2	N/A	
Ch 1 Cal Mode	2010	2	N/A	
Ch 2 Cal Mode	2011	2	N/A	
Alarm ACK / Reset	12001	1	5	Write TRUE to ACK; resets to FALSE
Ch 1 D2A Raw	31001	4	N/A	10 bit value; 200 = 4mA, 1000 = 20mA
Ch 2 D2A Raw	31002	4	N/A	10 bit value; 200 = 4mA, 1000 = 20mA
Ch 1 A2D Raw	31003	4	N/A	10 bit value from A/D converter
Ch 2 A2D Raw	31004	4	N/A	10 bit value from A/D converter
Ch 1 Status	31005	4	N/A	See Channel Status Word definition
Ch 2 Status	31006	4	N/A	See Channel Status Word definition
Alarm Status Word	31007	4	N/A	See Alarm Status Word definition
Transmitter Status Word	31008	4	N/A	See Transmitter Status Word definition
Ch 1 Sensor Life	31009	4	N/A	16 bit signed integer ranging from -1 to 100 where -1 indicates Cal Required
Ch 2 Sensor Life	31010	4	N/A	16 bit signed integer ranging from -1 to 100 where -1 indicates Cal Required
Ch 1 Sensor Temp	31011	4	N/A	16 bit integer from 1 to 4095 scaled for -55°C to +125°C
Ch 2 Sensor Temp	31012	4	N/A	16 bit integer from 1 to 4095 scaled for -55°C to +125°C
Ch 1 Floating Point	33001	4	N/A	See Channel Floating Point definition

CH 2 Floating Point	33002	4	N/A	See Channel Floating Point definition
Ch 1 Measurement Name	40401 - 40408	3	N/A	16 ASCII characters (2 per register)
Ch 2 Measurement Name	40409 – 40416	3	N/A	16 ASCII characters (2 per register)
Ch 1 ASCII Reading	40417 – 40419	3	N/A	6 ASCII characters (2 per register)
Ch 2 ASCII Reading	40420 – 40422	3	N/A	6 ASCII characters (2 per register)
Ch 1 EUNITS	40423 – 40427	3	N/A	10 ASCII characters (2 per register)
Ch 2 EUNITS	40428 – 40432	3	N/A	10 ASCII characters (2 per register)
Ch 1 Preamp gain	40433	3	N/A	Contact factory
Ch 2 Preamp gain	40434	3	N/A	Contact factory
Firmware Version	40435 – 40436	3	N/A	4 ASCII characters (2 per register)
Ch 1 Cal Zero Real	41001	3	N/A	Real value without decimal point
Ch 1 Cal Zero Divisor	41002	3	N/A	Divisor = 1, 10, 100 or 1000
Ch 1 Cal Span Real	41003	3	N/A	
Ch 1 Cal Span Divisor	41004	3	N/A	
Ch 1 Zero Real	41005	3	N/A	
Ch 1 Zero Divisor	41006	3	N/A	
Ch 1 Span Real	41007	3	N/A	
Ch 1 Span Divisor	41008	3	N/A	
Ch 1 Fault Real	41009	3	N/A	
Ch 1 Fault Divisor	41010	3	N/A	
Ch 1 Alarm 1 Real	41011	3	N/A	
Ch 1 Alarm 1 Divisor	41012	3	N/A	
Ch 1 Alarm 2 Real	41013	3	N/A	
Ch 1 Alarm 2 Divisor	41014	3	N/A	
Ch 1 Alarm 3 Real	41015	3	N/A	
Ch 1 Alarm 3 Divisor	41016	3	N/A	
Ch 1 Man Gain Real	41017	3	N/A	
Ch 1 Man Gain Divisor	41018	3	N/A	
Ch 1 Man Offset Real	41019	3	N/A	
Ch 1 Man Offset Divisor	41020	3	N/A	
Ch 2 Cal Zero Real	41021	3	N/A	Real value without decimal point
Ch 2 Cal Zero Divisor	41022	3	N/A	Divisor = 1, 10, 100 or 1000
Ch 2 Cal Span Real	41023	3	N/A	
Ch 2 Cal Span Divisor	41024	3	N/A	
Ch 2 Zero Real	41025	3	N/A	
Ch 2 Zero Divisor	41026	3	N/A	

Ch 2 Span Real	41027	3	N/A	
Ch 2 Span Divisor	41028	3	N/A	
Ch 2 Fault Real	41029	3	N/A	
Ch 2 Fault Divisor	41030	3	N/A	
Ch 2 Alarm 1 Real	41031	3	N/A	
Ch 2 Alarm 1 Divisor	41032	3	N/A	
Ch 2 Alarm 2 Real	41033	3	N/A	
Ch 2 Alarm 2 Divisor	41034	3	N/A	
Ch 2 Alarm 3 Real	41035	3	N/A	
Ch 2 Alarm 3 Divisor	41036	3	N/A	
Ch 2 Man Gain Real	41037	3	N/A	
Ch 2 Man Gain Divisor	41038	3	N/A	
Ch 2 Man Offset Real	41039	3	N/A	
Ch 2 Man Offset Divisor	41040	3	N/A	
Ch 1 A2D MIN	41041	3	N/A	Min and max points for A/D and D/A
Ch 1 A2D MAX	41042	3	N/A	
Ch 1 D2A MIN	41043	3	N/A	
Ch 1 D2A MAX	41044	3	N/A	
Ch 2 A2D MIN	41045	3	N/A	
Ch 2 A2D MAX	41046	3	N/A	
Ch 2 D2A MIN	41047	3	N/A	
Ch 2 D2A MAX	41048	3	N/A	

CHANNEL STATUS WORD BIT DEFINITION

Channel Status Word	Bit 0	Alarm 1 Below (1), Alarm 1 Above (0)
	Bit 1	Alarm 2 Below (1), Alarm 2 Above (0)
	Bit 2	Alarm 3 Below (1), Alarm 3 Above (0)
	Bit 3	Alarm 1 Latch (1), Alarm 1 not latch (0)
	Bit 4	Alarm 2 Latch (1), Alarm 2 not latch (0)
	Bit 5	Alarm 3 Latch (1), Alarm 3 not latch (0)
	Bit 6	Alarm 3 Active (1), Alarm 3 fault only (0)
	Bit 7	Channel Disabled (1), Channel Enabled (0)
	Bit 8	Channel in Cal (1), Channel not in Cal (0)
	Bit 9	Channel Temp Compensation (1), no temp comp (0)
	Bit 10	Fault Relay Latch (1), no fault relay latch (0)
	Bit 11	Display (Track) Negative (1), no display negative (0)
	Bit 12	Transmit Sensor Life (1), no transmit sensor life (0)
	Bit 13-15	Reserved

ALARM STATUS WORD BIT DEFINITION

Alarm Status Word	Bit 0	Ch 1 Alarm 1 (1), no alarm (0)
	Bit 1	Ch 1 Alarm 2 (1), no alarm (0)
	Bit 2	Ch 1 Fault (1), no fault (0)
	Bit 3	Reserved
	Bit 4	Ch 2 Alarm 1 (1), no alarm (0)
	Bit 5	Ch 2 Alarm 2 (1), no alarm (0)
	Bit 6	Ch 2 Fault (1), no fault (0)
	Bit 7	Reserved
	Bit 8	Relay 1 Energized (1), no relay (0)
	Bit 9	Relay 2 Energized (1), no relay (0)
	Bit 10	Relay 3 Energized (1), no relay (0)
	Bit 11-15	Reserved

TRANSMITTER STATUS WORD BIT DEFINITION

Transmitter Status Word	Bit 0	Ch 1 Active (1), Ch 1 inactive (0)
	Bit 1	Ch 2 Active (1), Ch 2 inactive (0)
	Bit 2	Secure Level (1), no security (0)
	Bit 3	Marker Tx LED (1), no marker (0)
	Bit 4-11	Reserved
	Bit 12	Relay 1 Failsafe (1), normal (0)
	Bit 13	Relay 2 Failsafe (1), normal (0)
	Bit 14	Relay 2 Acknowledge (1), normal (0)
	Bit 15	Lock (1), not locked (0)

CHANNEL FLOATING POINT DEFINITION

10 SPECIFICATIONS

Model	GASMAX II Single / Dual Channel Gas Monitor
Power Input	10-30VDC at < 4 watts with relay board. Additional power required for Extended Temp & GDS-IR option.
Display	64 x128 pixel LCD with engineering units, bargraph and 30-minute trend
Channel One Input	Microamp-level input for local or remote GDS Corp toxic gas sensors Optional 4-20mA input for remote sensor transmitters, GDS-IR, GDS-50 or other 4-20mA source
Channel Two Input	Bridge-type input with adjustable excitation voltage for local or remote Catalytic Bead, SmartIR or PID sensor Optional 4-20mA input for remote sensor transmitters, GDS-IR, GDS-50 or other 4-20mA source
Accuracy	+/- 5% of full scale (typical)
Standard Output	Dual three-wire 4-20mA current source outputs with fault and overrange indication. Maximum loop resistance is 750 ohms with standard 24VDC supply Fault output = 0.0 mA for all fault conditions
Optional Output	Relay / MODBUS interface with 3x 5A SPDT programmable alarm relays Dual isolated 4-20mA outputs Single or dual input MODBUS slave interface (no relays)
Temperature	Electronics -40°C to +60°C. See Sensor Manual for additional details
Memory	On-board non-volatile memory retains all user settings
Housing	Aluminum housing with epoxy paint standard; #316 stainless steel optional One ¼" NPT female connection for local sensor head Two ¾" NPT female connections for conduit or cable glands
Dimensions	Width 5.4" (137 mm), Height 8" (203 mm), Depth 5" (127 mm) Shipping weight 6.5 pounds (3 kg)
Approvals	CSA Certified Division 1 & 2 Groups B, C, D. Suitable for explosion-proof installations with flame arrestor
Warranty	Two years on electronics, one year on sensor

11 SPARE PARTS

DISPLAY AND ENCLOSURE

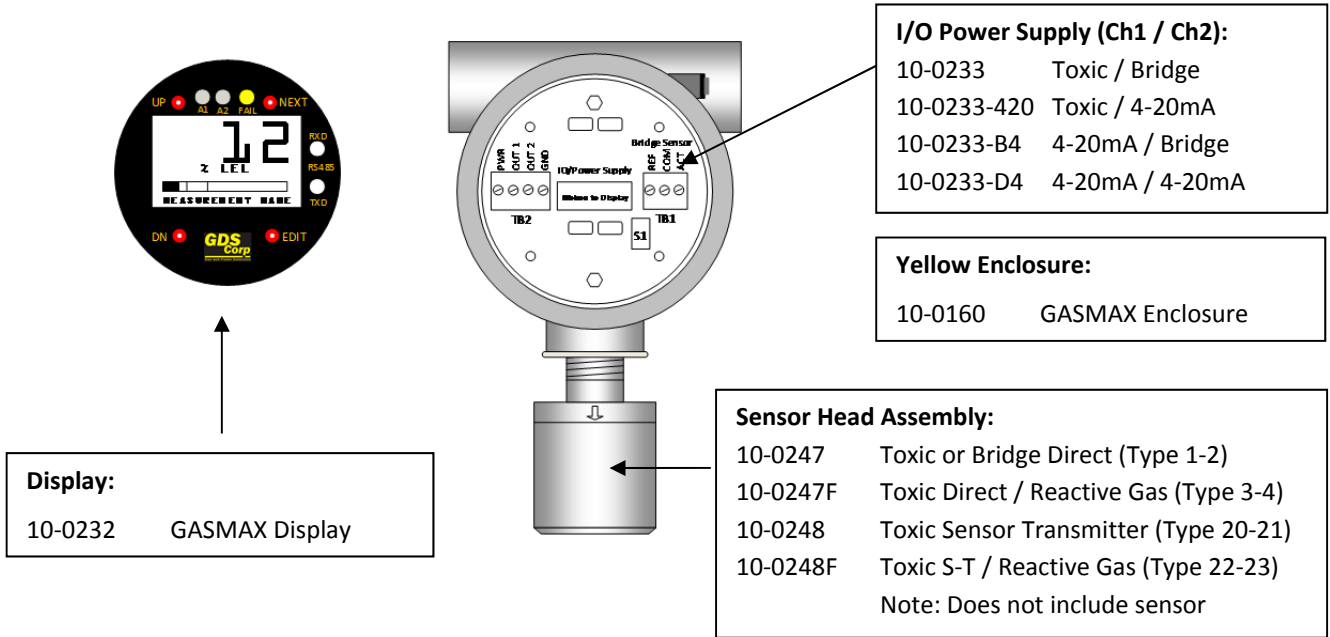

Figure 11-1: GASMAX II + Local Sensor Spare Parts

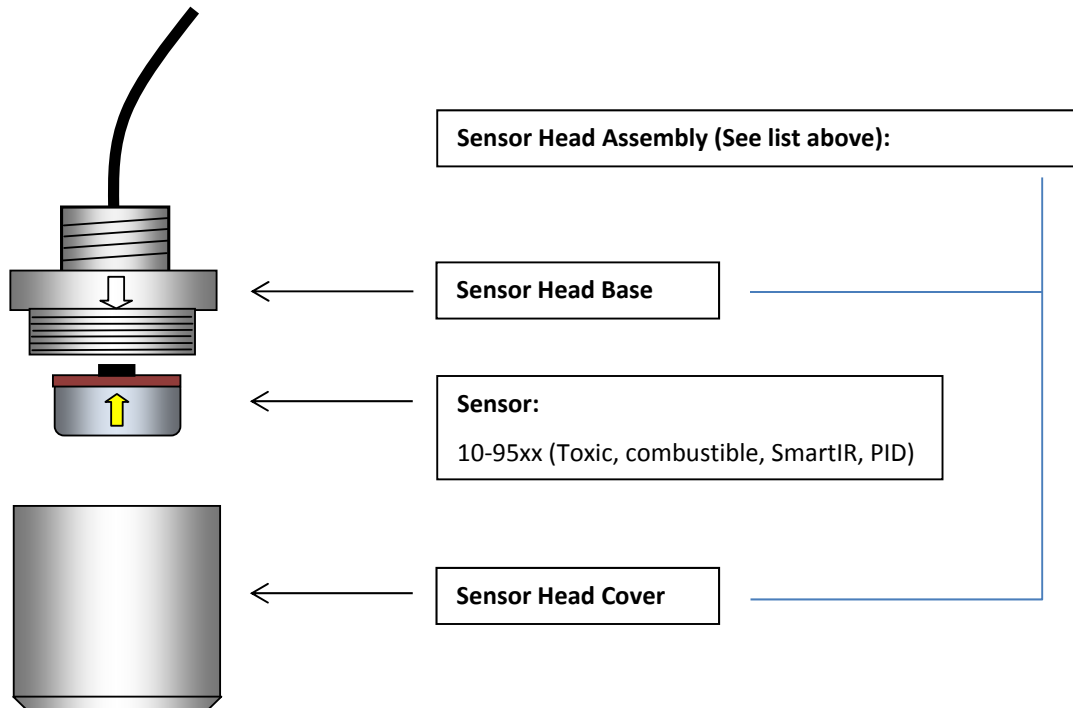

Figure 11-2: GASMAX Sensor Head

EXPANSION BOARDS

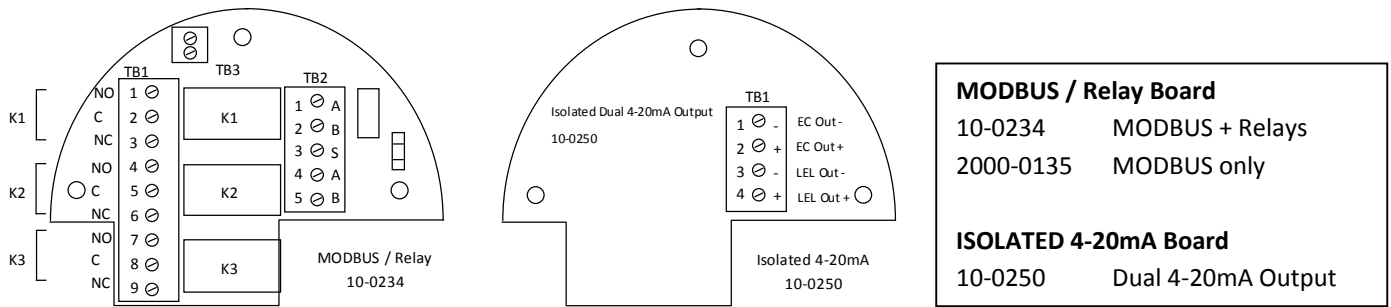

Figure 11-3: GASMAX Expansion Boards

SENSOR HEAD ACCESSORIES

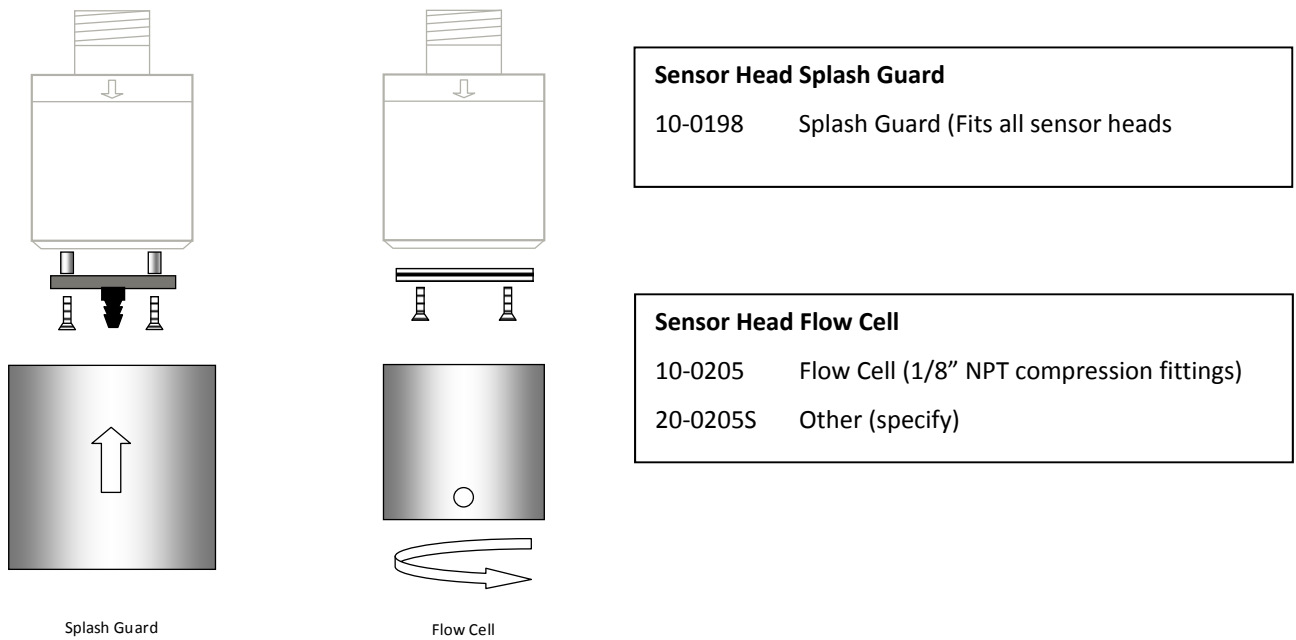
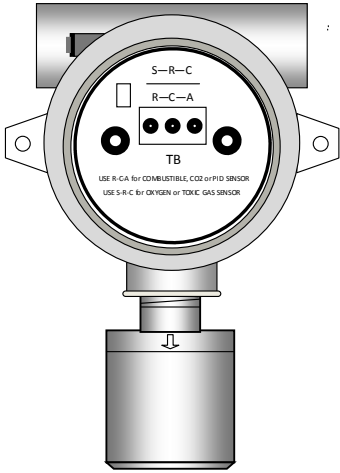

Figure 11-4: GASMAX Sensor Head Splash Guard & Flow Cell

REMOTE TOXIC OR BRIDGE SENSOR



Remote Sensor Head Assembly:

20-0126 Remote Toxic or Bridge Direct (Type 5-6)

20-0127 Remote Toxic / Reactive Gas (Type 7-8)

Note: Does not include sensor

Figure 11-5: GASMAX II Remote Direct Sensor Head

REMOTE TOXIC SENSOR TRANSMITTER

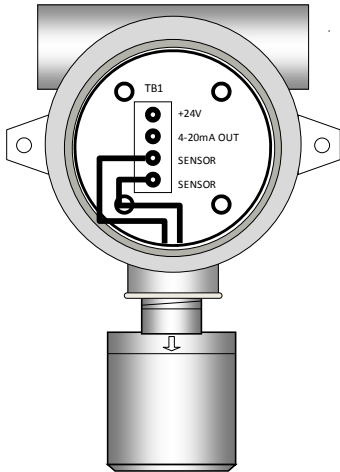

Remote Sensor Transmitter Head Assembly:

20-0129 Remote Toxic Sensor Transmitter (Type 24-25)

20-0130 Remote Toxic S-T / Reactive Gas (Type 26-27)

Note: Does not include sensor

Figure 11-6: GASMAX II Remote Sensor Transmitter

DUAL LOCAL SENSORS

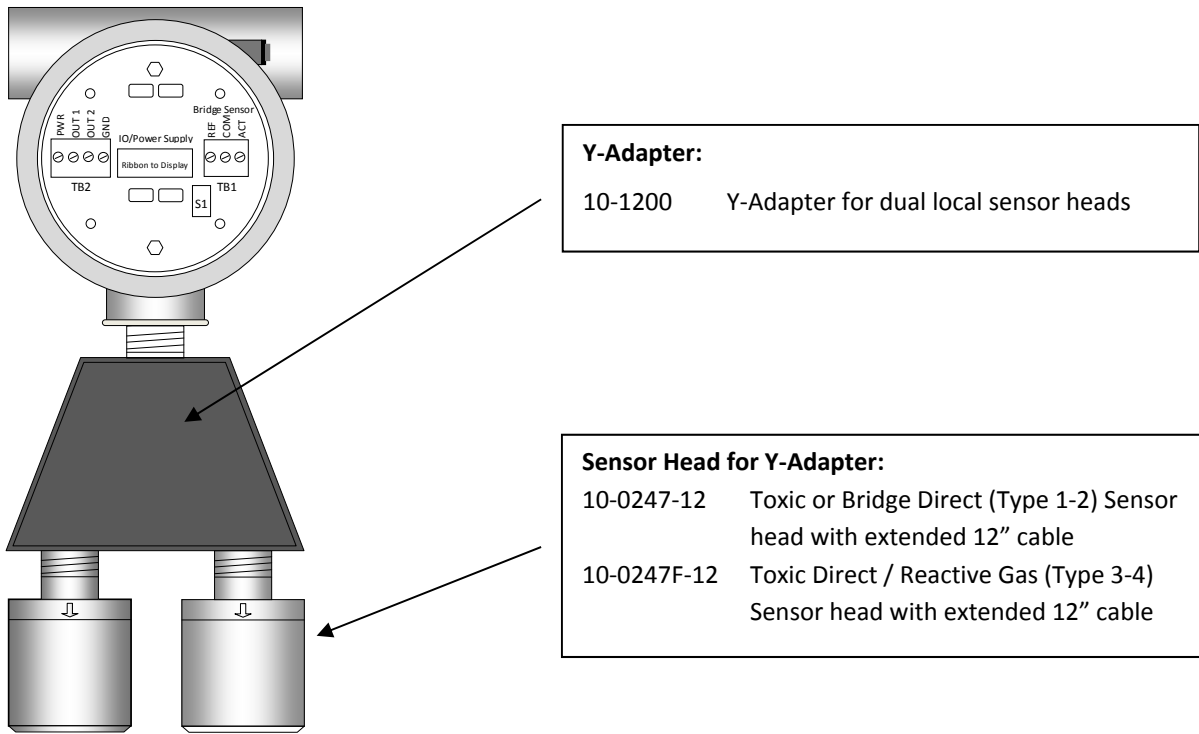

Figure 11-7: GASMAX II Dual with Y-Adapter

12 DRAWINGS AND DIMENSIONS

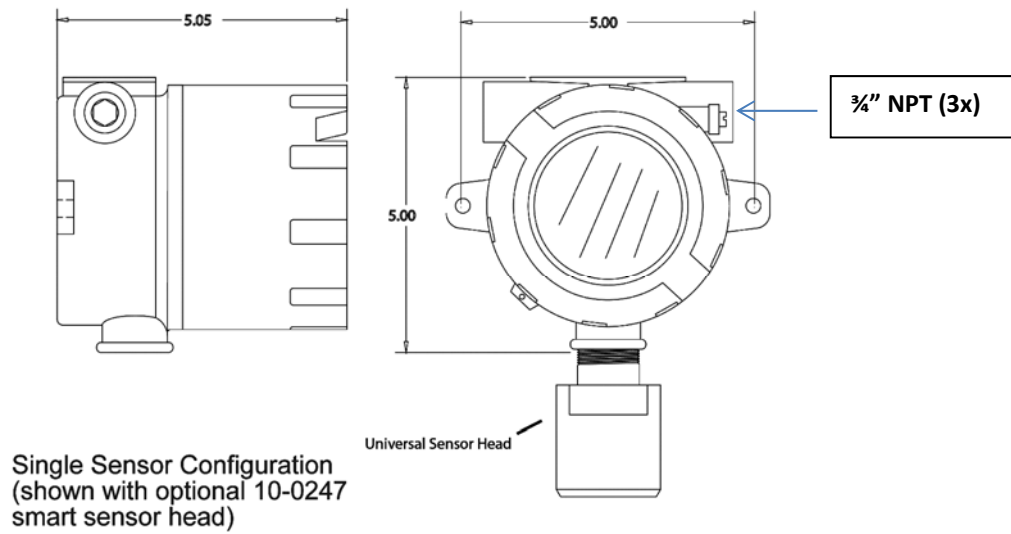

Figure 12-1: GASMAX Dimensions

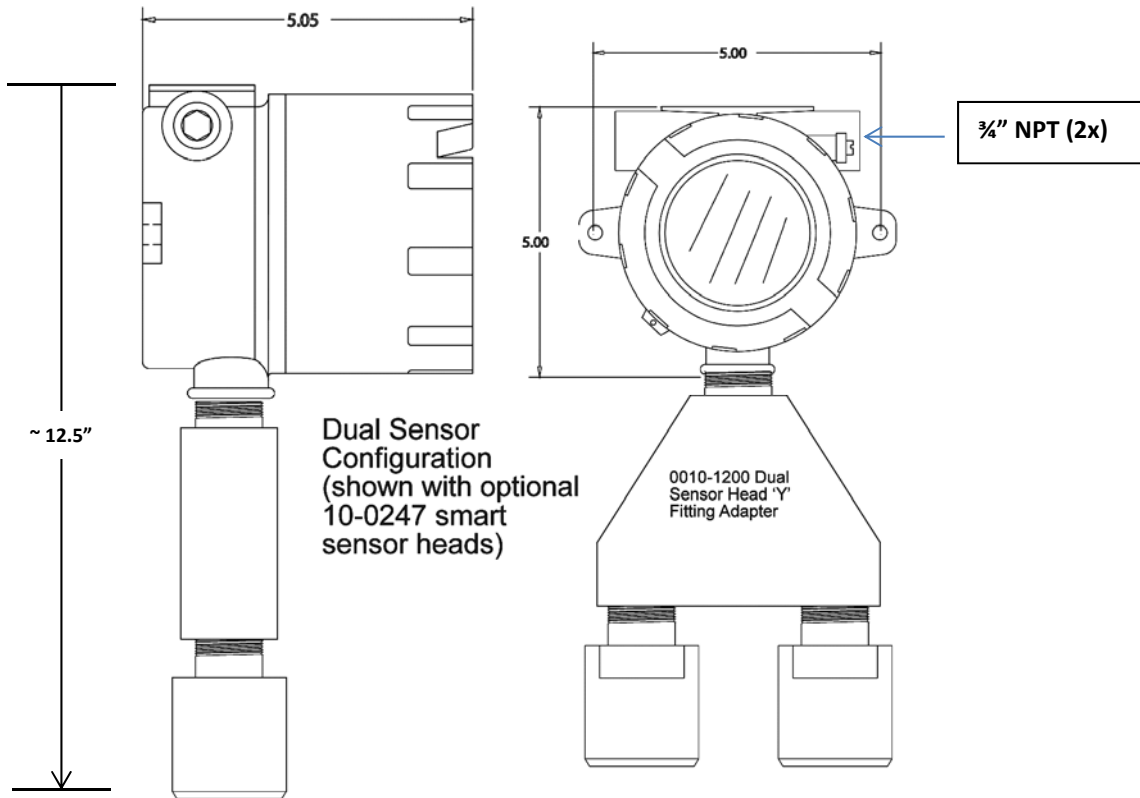

Figure 12-2: GASMAX Dual Local Sensor Dimensions



AUTHORIZED DISTRIBUTOR
GasDetectorsUSA.com - Houston, Texas USA
sales@GasDetectorsUSA.com - 281-643-0080