



Gas and Flame Detection

# Operation and Maintenance Manual

---

GASMAX ECx Battery-Powered Wireless Gas Monitor

---

AUTHORIZED DISTRIBUTOR  
GasDetectorsUSA.com - Houston, Texas USA  
[sales@GasDetectorsUSA.com](mailto:sales@GasDetectorsUSA.com) - 832-615-3588

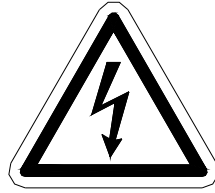

**CAUTION: FOR SAFETY REASONS THIS EQUIPMENT MUST BE OPERATED AND SERVICED BY QUALIFIED PERSONNEL ONLY. READ AND UNDERSTAND INSTRUCTION MANUAL COMPLETELY BEFORE OPERATING OR SERVICING.**

**ATTENTION: POUR DES RAISONS DE SÉCURITÉ, CET ÉQUIPEMENT DOIT ÊTRE UTILISÉ, ENTRETENU ET RÉPARÉ UNIQUEMENT PAR UN PERSONNEL QUALIFIÉ. ÉTUDIER LE MANUE D'INSTRUCTIONS EN ENTIER AVANT D'UTILISER, D'ENTRETENIR OU DE RÉPARER L'ÉQUIPEMENT.**

REVISION HISTORY

Revision 2.0 5/1/13 Update for GASMAX ECx

## CONTENTS

<b>1</b>	<b>SAFETY INFORMATION</b>	<b>8</b>
<b>2</b>	<b>GENERAL INFORMATION</b>	<b>9</b>
	Introduction	9
	GASMAX Display Screens	9
	Data Display Screen	10
	Trend Display Screen	11
	GASMAX ECx Sensors	11
	GASMAX ECx Wireless Communications Overview	12
<b>3</b>	<b>SPECIFICATIONS</b>	<b>13</b>
<b>4</b>	<b>INSTALLATION</b>	<b>16</b>
	Locating the GASMAX ECx	16
	Mounting the GASMAX Instrument Enclosure	17
	Wireless Communications Considerations	17
	Mounting the GASMAX Remote Toxic Sensor Enclosure	18
	Use in Hazardous Areas	18
	Local Smart Sensor	19
	Connecting a Remote Sensor	20
	Initial Setup	21
<b>5</b>	<b>CALIBRATION</b>	<b>22</b>
	Calibration Overview	22
	Calibration Procedure	23
<b>6</b>	<b>OPERATION AND MAINTENANCE</b>	<b>25</b>
	Normal Wireless Operation	25

<b>Alarm Operation – ALARM 1 and 2</b>	<b>25</b>
<b>Alarm Operation – ALARM 3</b>	<b>25</b>
<b>Sensor Replacement</b>	<b>26</b>
<b>Sensor Replacement – Remote Sensors</b>	<b>27</b>
<b>Normal Maintenance</b>	<b>27</b>
<b>7 USER MENUS</b>	<b>29</b>
<b>Main Menu</b>	<b>29</b>
<b>System Configuration Page</b>	<b>30</b>
USER INFO	30
Eunits	30
Zero (0%)	30
Span (100%)	30
Decimal Points	30
Cal Span Value	30
Readout Deadband	30
Track Negative	30
Backup Config	31
Restore Config	31
Upload Sensor Data	31
<b>Alarm Settings Page</b>	<b>31</b>
Set Point	31
Dead-Band	31
ON Delay	32
OFF Delay	32
Low Trip	32
Latching	32
Display Event Log	32
Clear Event Log	32
<b>Sensor settings page</b>	<b>32</b>
Install New Sensor	32

Recall Cal History _____	32
Input Type _____	33
New Sensor _____	33
Recent Cal _____	33
<b>Clock Delay Setup Page _____</b>	<b>33</b>
Time _____	33
Date _____	33
Warm Up Delay _____	33
Cal Purge Delay _____	33
<b>LCD Contrast Page _____</b>	<b>33</b>
<b>System Security Page _____</b>	<b>33</b>
Contact Name _____	34
Secure Level _____	34
<b>Radio Setup Page _____</b>	<b>34</b>
Hop Channel _____	34
Remote ID _____	35
System ID _____	35
TX Power _____	35
TX Verbose _____	35
Radio Status _____	35
<b>8 TECHNICIANS MENUS _____</b>	<b>36</b>
<b>TECHNICAL PAGE Menu _____</b>	<b>36</b>
Set Balance _____	36
Set Voltage _____	36
Preamp Gain Set _____	37
Input Type _____	37
Zero Cal Value _____	38
Raw Min / Max Counts _____	38
<b>9 TROUBLESHOOTING GUIDE _____</b>	<b>39</b>
<b>Toxic Sensor Indicates Fault or Overrange _____</b>	<b>39</b>
<b>Toxic Sensor Will Not Calibrate _____</b>	<b>39</b>

Receiving Device and GASMAX Displayed Values Don't Match	39
Controller Receiver shows Comm Error	39
GASMAX Display Blank	39
GASMAX Error Codes	40
<b>10 SPARE PARTS</b>	<b>41</b>
Display & Enclosure	41
Sensor Head Accessories	42
Remote Sensor	42

**TABLE OF FIGURES**

FIGURE 2-1: GASMAX ECX DATA & TREND SCREENS _____	10
FIGURE 2-2: GASMAX ECX DATA DISPLAY SCREEN _____	10
FIGURE 2-3: GASMAX ECX TREND DISPLAY SCREEN _____	11
FIGURE 3-1: RECOMMENDED TOXIC SENSOR TEMPERATURE RANGES _____	14
FIGURE 3-2: RECOMMENDED TOXIC SENSOR WARMUP TIMES _____	14
FIGURE 3-3: TOXIC SENSOR RANGES _____	15
FIGURE 4-1: GASMAX ECX DIMENSIONS _____	16
FIGURE 4-2: WIRELESS TRANSMISSION CONSIDERATIONS (ANTENNA HEIGHT) _____	17
FIGURE 4-3: REMOTE TOXIC SENSOR DIMENSIONS _____	18
FIGURE 4-4: LOCAL SMART TOXIC SENSOR _____	19
FIGURE 4-5: REMOTE SENSOR WIRING _____	20
FIGURE 4-6: MAIN POWER SWITCH _____	21
FIGURE 5-1: CALIBRATION SETUP _____	23
FIGURE 5-2: CALIBRATION FLOWCHART _____	24
FIGURE 6-1: SENSOR REPLACEMENT _____	26
FIGURE 6-2: SMART SENSOR RECOGNITION SCREEN _____	27
FIGURE 7-1: MAIN MENU FLOWCHART _____	29
FIGURE 7-2: SYSTEM CONFIG MENU _____	30
FIGURE 7-3: ALARM SETTINGS MENU _____	31
FIGURE 7-4: SENSOR SETTINGS MENU _____	32
FIGURE 7-5: CLOCK DELAY MENU _____	33
FIGURE 7-6: CONTRAST MENU _____	33
FIGURE 7-7: SYSTEM SECURITY MENU _____	34
FIGURE 8-1: TECHNICAL PAGE MENU _____	36
FIGURE 8-2: SET GAIN TO UNITY MENU _____	37
FIGURE 8-3: PREAMP GAIN SET MENU _____	37
FIGURE 10-1: GASMAX ECX + LOCAL SENSOR SPARE PARTS _____	41
FIGURE 10-2: GASMAX SENSOR HEAD SPLASH GUARD& FLOW CELL _____	42
FIGURE 10-3: GASMAX ECX REMOTE DIRECT SENSOR HEAD _____	42

## 1 SAFETY INFORMATION

### Important – Read Before Installation

Users should have a detailed understanding of GASMAX ECX operating and maintenance instructions. Use the GASMAX ECX only as specified in this manual or detection of gases and the resulting protection provided may be impaired. Read the following WARNINGS prior to use.

#### WARNINGS

- The GASMAX ECx gas monitor described in this manual must be installed, operated and maintained in accordance with information contained herein. Installation in any hazardous area must comply with all applicable restrictions, requirements and guidelines for said hazardous areas. It is the end user customer's final decision to ensure that the GASMAX ECX is suitable for the intended use.
- The GASMAX ECx is designed and constructed to measure the level of certain gases in ambient air. Accuracy in atmospheres containing steam or inert gases cannot be guaranteed.
- Always mount the sensor head vertically with the sensor head facing down.
- Do not paint transmitter or sensor assembly.
- Do not operate the GASMAX ECx if its enclosure is damaged or cracked or has missing components. Make sure the cover, internal PCB's and field wiring are securely in place before applying power.
- Do not expose the GASMAX ECx to electrical shock or continuous severe mechanical shock. Protect the GASMAX ECx and related sensor assemblies from dripping liquids and high power sprays.
- Calibrate with known target gas at start-up and check on a regular schedule, at least every 90 days. More frequent inspections are encouraged to spot problems such as dirt, oil, paint, grease or other foreign materials on the sensor head.
- Periodically test for correct operation of the system's alarm events by exposing the monitor to a targeted gas concentration above the High Alarm set point.
- Use only for applications described within this manual.



## 2 GENERAL INFORMATION

### Introduction

The GASMAX ECx is a single channel, battery-powered wireless gas monitor designed to provide continuous monitoring of toxic or combustible gases at fixed locations. Gas values are displayed in calibrated engineering units as well as bar graph or 30-minute trend graph format.

The GASMAX ECx supports one local or remote mount sensor for toxic or hydrocarbon gas. The advanced microcontroller, non-intrusive magnetic interface and superior graphic LCD interface offers rapid setup, simplified operation and enhanced diagnostics not found in previous generation products. On-board non-volatile memory retains all configuration data during power interruptions.

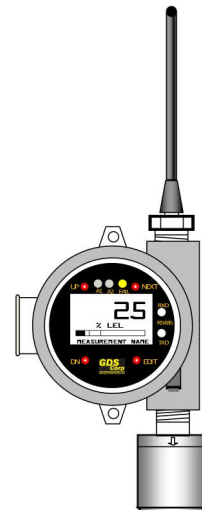

GDS Corp Smart Sensors include range values and configuration data that are uploaded to the GASMAX ECx (local sensors only) when the sensor is plugged in, or when power is applied. This allows users to configure the GASMAX ECx for different gases by simply changing the sensor.

The GASMAX ECx includes a 3.6v lithium-ion battery and fully integrated frequency-hopping spread-spectrum (FHSS) radio transmitter that allows the ECx to transmit gas readings to any GDS Corp wireless controller / receiver, wireless system manager or wireless alarm station. All wireless parameters, including transmit power, hop frequency selection and security codes are configurable from the main menu. Both 900 MHz and 2.4 GHz models are available and allow for world-wide operation without licensing restrictions.

Built-in user-prompted calibration makes it easy for one person to perform calibration and maintenance without opening the enclosure or declassifying the area. A battery-powered real-time clock and event log allows the GASMAX ECx to track calibration and alarm events for later recall on the LCD readout.

### GASMAX Display Screens

The GASMAX display is shown in Figure 2-1. There are four magnetic switches on the face of the GASMAX II, arranged in a quadrant around the LCD display. Starting in the upper right and proceeding clockwise these are labeled NEXT, EDIT, DOWN/CAL and UP.

To activate, or “press” a magnetic switch, swipe the magnet near the switch.

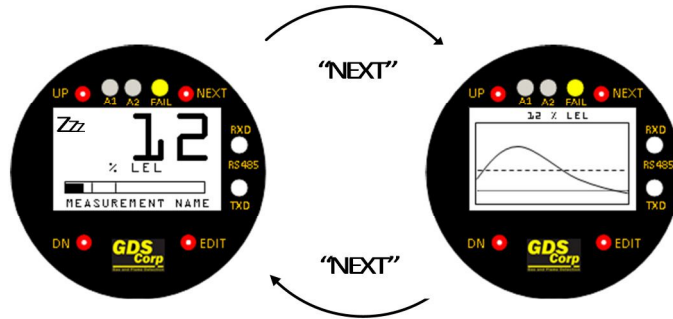

Figure 2-1: GASMAX ECX Data & Trend Screens

Pressing the NEXT key causes the GASMAX display to switch display screens between DATA and TREND displays. The EDIT key activates the USER MENU display mode. When in user menu display mode, use UP and DOWN to select an item, EDIT to change an item, and NEXT to exit the menu or function and return the GASMAX ECX to display mode. Activating DOWN/CAL, followed by EDIT, while in display mode initiates calibration mode. For the balance of this manual, the term “press” will be used to describe activation of any key via the magnetic wand.

### Data Display Screen

The DATA display screen shows a single channel’s information. The current value is shown in calibrated engineering units. A horizontal bargraph tracks the current value and shows the Alarm 1 and Alarm 2 values in graphical form. The user-programmable Engineering Units (“Eunits”) and Measurement Name text strings are shown below the real-time reading. Above the LCD display, three LEDs indicate the status of the level and fault alarms. A radio status icon in the upper left corner indicates the status of the wireless interface.

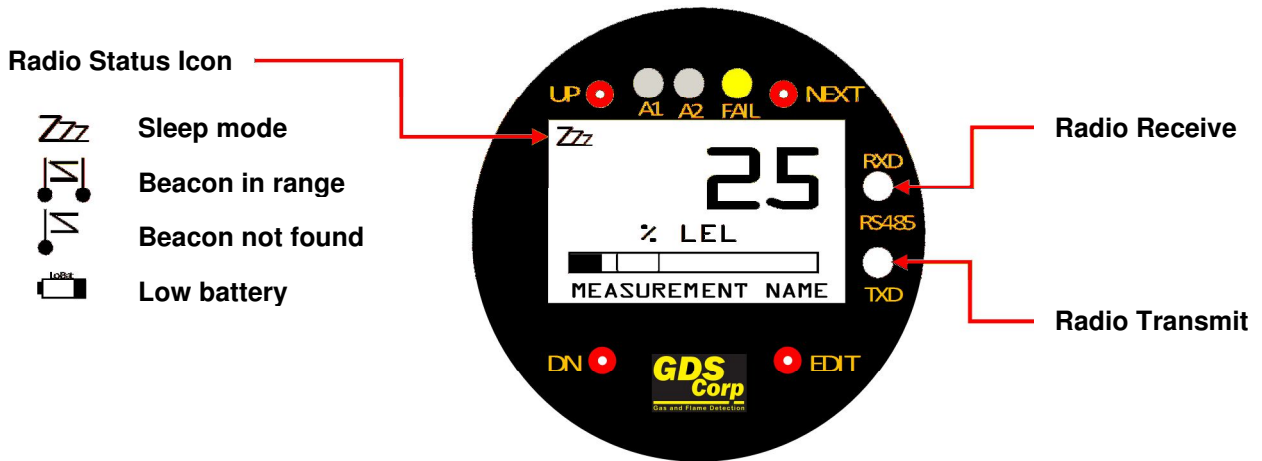

Figure 2-2: GASMAX ECx Data Display Screen

### Trend Display Screen

The TREND display shows a graphical representation of the most recent 30 minute trend. The Alarm 1 level is shown as a closely spaced dotted line, and the Alarm 2 level is shown as a widely spaced dashed line. Note that once the gas value exceed the Alarm 1 value, the GASMAX ECx will begin transmitting data at six second intervals.

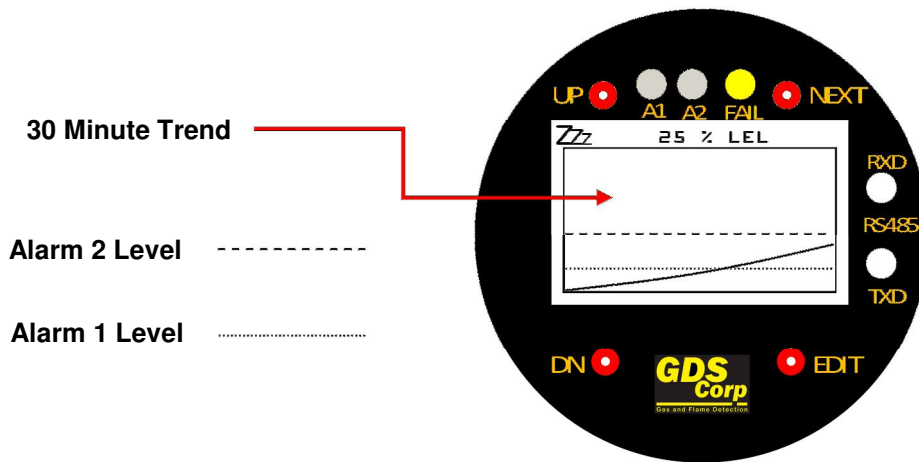

Figure 2-3: GASMAX ECx TREND Display Screen

### GASMAX ECx Sensors

For toxic gases the GASMAX ECx supports a wide range of electrochemical (“echem”) sensors. These sensors use chemical reactions to sense the presence of gases such as hydrogen sulfide, chlorine, sulfur dioxide and many others. Echem sensors output very low level signals; remote echem sensors should be mounted no more than 15 feet from the GASMAX enclosure, the wiring should be three-conductor with foil shield, and the wiring should be enclosed in metal conduit for maximum protection against interference.

**IMPORTANT: TOXIC SENSORS ARE SUBJECT TO ACCELERATED DETERIORATION IF POWER IS NOT SUPPLIED WITHIN 3 MONTHS OF SHIPMENT FROM GDS CORP.**

For combustible gases, the GASMAX ECx supports an ultra-low power infrared sensor that detects hydrocarbon gases such as methane, propane, hexane and others.

**IMPORTANT: THE GASMAX ECX INFRARED SENSOR WILL NOT DETECT COMBUSTIBLE LEVELS OF HYDROGEN GAS.**

## **GASMAX ECx Wireless Communications Overview**

GDS Corp wireless gas monitors utilize a frequency hopping spread spectrum (FHSS) network that uses a centrally broadcast beacon signal to maintain synchronization and minimize power consumption. FFSH radios for both 900 MHz and 2.4 GHz are available. For North America, 900 MHz is recommended due to increased power output available (up to 1 watt), greater range and ability of lower frequency signals to travel around interfering objects. Systems utilizing 2.4 GHz radios transmit at lower power levels and have corresponding less range. In addition, higher frequency 2.4 GHz signals tend to require a more direct 'line of sight' between the gas detector and controller / receiver antenna. On the other hand, 2.4 GHz systems are generally license-free world-wide and are generally less prone to interference from other radio frequency sources. A decision on which to choose should be based on location, distance, existing

**IMPORTANT: CHOICE OF FREQUENCY IS MADE AT TIME OF ORDER. SYSTEMS DESIGNED FOR 900 MHZ CANNOT BE FIELD UPGRADED TO 2.4 GHZ AND VICE-VERSA.**

Once the choice of frequency band is made, every radio in each unique network must also have a matching **Hop Channel** (0-32) and **System ID** (0-255) setting, along with a unique **Device ID** (1-240) that allows the controller to identify the specific gas detector. Finally, there must be one device that transmits the **Beacon** signal that all radios use to synchronize their spread spectrum transmission. For GDS Corp networks, this would generally be the GDS-98 Wireless System Manager, C2 Quad Protector Wireless Controller / Receiver or C64 Protector Controller / Receiver.

**NOTE: GDS CORP WIRELESS GAS DETECTORS CAN ONLY COMMUNICATE WITH PROPERLY EQUIPPED GDS CORP CONTROLLERS OR WIRELESS SYSTEM MANAGERS.**

Every six seconds, the microprocessor in the GASMAX ECx wakes up and reads the output of the electrochemical or infrared sensor, converts the reading into calibrated engineering units and compares the reading to the preset Alarm 1 setting. If the current reading exceeds the Alarm 1 value, the microprocessor commands the radio to transmit a packet of data at the next available hop interval. This packet includes the gas value, alarm status bits, battery voltage and other data. If the current reading is below the Alarm 1 setting, the GASMAX ECx microprocessor will return to sleep mode until the end of the next six second interval. Irrespective of the gas level, the GASMAX ECx transmits a data packet at least every five minutes; this allows the controller / receiver / wireless system manager to ensure that a COMM ERROR signal is generated if the GASMAX ECx fails to transmit. The complete sequence takes anywhere from 0.25 to 1 second to complete.

### 3 SPECIFICATIONS

Power Source	Disposable 3.6v Lithium-Ion battery (D-size)
Display	64 x128 pixel LCD with engineering units, bargraph and 30-minute trend
Input	Accepts microamp-level inputs from local or remote GDS Corp toxic or oxygen deficiency sensors; accepts digital input from GDS Corp low power infrared sensors
Accuracy	+/- 5% of full scale (typical)
RF Section (900 MHz)	User adjustable transmit power from 10 mW ( ) to 1.0 watt (+30 dBm); frequency range from 902 to 928 MHZ. Beacon receiver sensitivity -100 dBm.
RF Section (2.4 GHz)	Fixed transmit power of 50 mW. Frequency range from 2.406 GHz to 2.435 GHz in 'low band' and from 2.444 GHz to 2.472 GHz for 'high band'. Beacon receiver sensitivity -100 dBm.
Temperature	-40°C to +60°C (electronics only; see sensor recommendations below)
Memory	On-board non-volatile memory retains all user settings
Housing	Aluminum housing with epoxy paint standard; #316 stainless steel optional
Dimensions	Width 5.4" (137 mm), Height 8" (203 mm), Depth 5" (127 mm) Shipping weight 6.5 pounds (3 kg)
Approvals	CSA Certified Division 1 &
Warranty	Two years on electronics, one year on sensor

10	Oxygen	-30°C to + 55°C	21	Ozone	-20°C to + 40°C
11	Carbon Monoxide	-30°C to + 50°C	22	Ethylene Oxide	-20°C to + 50°C
12	Chlorine	-20°C to + 50°C	23	Arsine	-20°C to + 40°C
13	Chlorine Dioxide	-20°C to + 40°C	24	Silane	-20°C to + 40°C
14	Hydrogen	-20°C to + 50°C	25	Fluorine	-10°C to + 40°C
15	Hydrogen Sulfide	-30°C to + 50°C	26	Phosgene	-20°C to + 40°C
16	Hydrogen Cyanide	-20°C to + 50°C	27	Hydrazine	-10°C to + 40°C
17	Hydrogen Chloride	-20°C to + 50°C	28	Nitric Oxide	-20°C to + 50°C
18	Hydrogen Fluoride	-20°C to + 50°C	29	Nitrogen Dioxide	-20°C to + 50°C
19	Sulfur Dioxide	-30°C to + 50°C	30	Mercaptan	-10°C to + 40°C
20	Ammonia	-20°C to + 40°C	31	Tetrahydrothiophene	-10°C to + 40°C
			32	Diborane	-20°C to + 40°C

**Figure 3-1: Recommended Toxic Sensor Temperature Ranges**

10	Oxygen	2 to 4 hours	22	Ethylene Oxide	8 to 12 hours
11	Carbon Monoxide	2 to 4 hours	23	Arsine	8 to 12 hours
12	Chlorine	8 to 12 hours	24	Silane	8 to 12 hours
13	Chlorine Dioxide	8 to 12 hours	25	Fluorine	8 to 12 hours
14	Hydrogen	2 to 4 hours	26	Phosgene	8 to 12 hours
15	Hydrogen Sulfide	2 to 4 hours	27	Hydrazine	8 to 12 hours
16	Hydrogen Cyanide	8 to 12 hours	28	Nitric Oxide	8 to 12 hours
17	Hydrogen Chloride	8 to 12 hours	29	Nitrogen Dioxide	8 to 12 hours
18	Hydrogen Fluoride	8 to 12 hours	30	Mercaptan	8 to 12 hours
19	Sulfur Dioxide	4 to 8 hours	31	Tetrahydrothiophene	8 to 12 hours
20	Ammonia	4 to 8 hours	32	Diborane	8 to 12 hours
21	Ozone	8 to 12 hours	33	H2S Low Humidity	2 to 4 hours

**Figure 3-2: Recommended Toxic Sensor Warmup Times**

Sensor Type	Sensor	Minimum Range	Maximum Range	Comments
10	Oxygen	0-25% by volume	0-25% by volume	
11	Carbon Monoxide	0-100 ppm	0-9999 ppm	
12	Chlorine*	0-5 ppm	0-50 ppm	
13	Chlorine Dioxide*	0-1 ppm	0-1 ppm	
14	Hydrogen	0-1000 ppm	0-4% by volume	
15	Hydrogen Sulfide	0-10 ppm	0-9999 ppm	
16	Hydrogen Cyanide	0-30 ppm	0-30 ppm	
17	Hydrogen Chloride*	0-30 ppm	0-30 ppm	
18	Hydrogen Fluoride*	0-5 ppm	0-10 ppm	
19	Sulfur Dioxide	0-50 ppm	0-500 ppm	
20	Ammonia*	0-50 ppm	0-1000 ppm	
21	Ozone*	0-1 ppm	0-1 ppm	
22	Ethylene Oxide	0-50 ppm	0-200 ppm	
23	Arsine	0-1 ppm	0-1 ppm	
24	Silane	0-25 ppm	0-50 ppm	
25	Fluorine*	0-1 ppm	0-1 ppm	
26	Phosgene*	0-1 ppm	0-1 ppm	
27	Hydrazine	0-1 ppm	0-1 ppm	
28	Nitric Oxide	0-25 ppm	0-100 ppm	
29	Nitrogen Dioxide	0-50 ppm	0-200 ppm	
30	Mercaptan	0-15 ppm	0-30 ppm	
31	Tetrahydrothiophene	0-15 ppm	0-30 ppm	
32	Diborane	0-1 ppm	0-5 ppm	
33	H2S Low Humidity	0-100 ppm	0-500 ppm	

**Figure 3-3: Toxic Sensor Ranges**

## 4 INSTALLATION

### Locating the GASMAX ECx

Factors such as air movement, gas density in relation to air, emission sources and environmental variables affect correct sensor location. Air movement by fans, prevailing winds and convection should be carefully evaluated to determine if a leak is more likely to raise gas levels in certain areas within the facility. Vapor density of a gas determines if it will rise or fall in air when there are no significant currents. Lighter than air gases should have the monitors mounted 12 – 18 inches (30 – 45 cm) above the potential gas leak and heavier than air gases should be this distance below. Even though the GASMAX ECx is designed for rugged service, sensors should be protected from environmental damage from water, snow, shock, vibration and dirt.

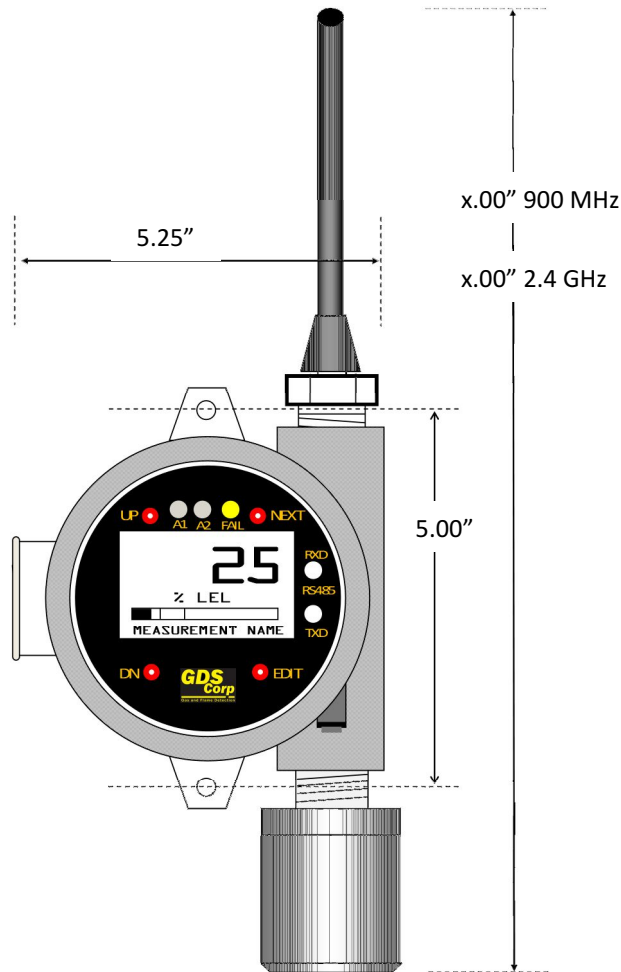

Figure 4-1: GASMAX ECx Dimensions



### Mounting the GASMAX Instrument Enclosure

The GASMAX ECx standard enclosure is a cast aluminum explosion-proof (NEMA 7) enclosure as shown in Figure 4-1. The GASMAX ECx should always be mounted with the sensor head opening facing down. If necessary, a Splash Guard (p/n 10-0205) should be attached if there is any chance that water or liquid spray could enter the sensor opening from below. Be sure to leave sufficient room (~ 12") below the sensor head to allow easy access for attachment of a Calibration Cup and / or removal of the sensor head cover for sensor replacement.

### Wireless Communications Considerations

Whenever possible, the GASMAX ECx should be mounted in a location that provides clear line-of-sight between the gas monitor and receiving antenna. Both 900 MHz and 2.4 GHz signals will travel through masonry or wooden structures with minimal loss; however, large metal buildings, tanks and other solid structures will block the signal or attenuate the transmissions to the point where reliable wireless communications may not be possible. For 900 MHz radios, power levels can be adjusted from 10 mW up to 1.0 watt (higher power will reduce battery life). In many cases, GDS-95 Wireless Repeaters can be used to route wireless signals around obstacles.

Height above ground also affects wireless transmissions, and raising the antenna at either end of the path will improve signal strength and reduce transmission errors. GDS Corp recommends placing the central receiver antenna at least 10 feet about the surrounding terrain, and even more if possible. However, note that standard vertical dipole antennas transmit their maximum signal strength in a relatively flat 'donut-shaped' pattern which may affect the performance of GASMAX ECx monitors located close to an elevated central antenna (see Fig. 4-2).

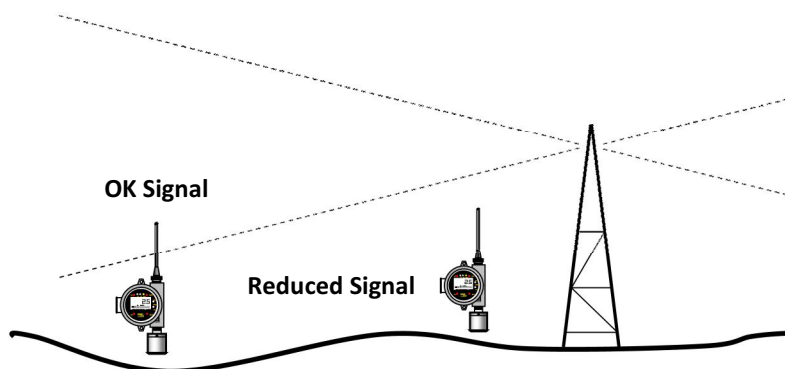

**Figure 4-2: Wireless Transmission Considerations (Antenna Height)**

GDS Corp always recommends that a wireless survey be completed at the site to ensure the integrity of the wireless communications link. Special care should be taken to account for moveable obstacles such as

cranes, railroad cars, trucks, containers, and any other large 'structures' that could end up being placed – temporarily – in a location that blocks the wireless signal.

### Mounting the GASMAX Remote Toxic Sensor Enclosure

The GASMAX ECX remote toxic sensor consists of a cast aluminum explosion-proof junction box and stainless steel sensor head (see Fig. 4-2). The junction box contains a PCB with connection point for the sensor head cable and wiring terminals for the three-wire connection to the GASMAX ECX display enclosure. Fittings are 3/4" NPT. The sensor head should ALWAYS be mounted vertically as shown, and GDS Corp recommends side entry for all conduit runs.

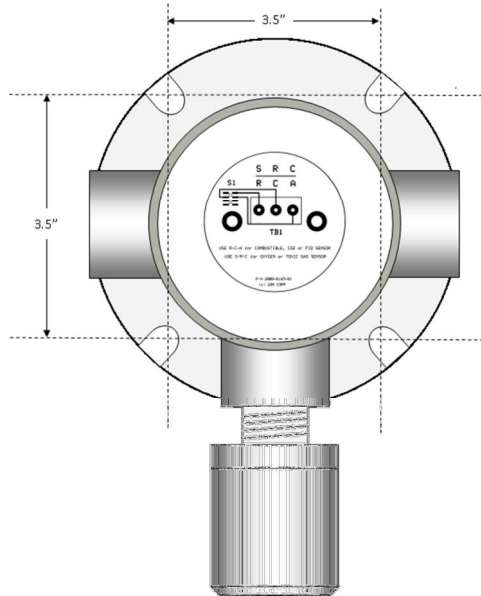

Figure 4-3: Remote Toxic Sensor Dimensions

**NOTE: THE ULTRA-LOW POWER INFRARED SENSOR FOR COMBUSTIBLE HYDROCARBON GASES IS FOR LOCAL MOUNT ONLY. CONTACT GDS CORP FOR MORE INFORMATION.**

### Use in Hazardous Areas

The GASMAX ECx enclosure and sensor head with integral flame arrestor are certified for use in Class 1 Division 1 hazardous areas. When combined with the optional XX Class I Division 1 antenna coupler, the entire device is suitable for use in Class 1 Division 1 areas. The standard 10-0295 antenna coupler is designed to meet Class I Division 2 hazardous area standards but is not 3<sup>rd</sup> party certified. GASMAX ECx detectors with sensor heads for reactive gases (without flame arrestors) should not be installed in hazardous areas.

### Local Smart Sensor

Local toxic or infrared combustible sensors are factory installed in a sensor head directly attached to the GASMAX ECx enclosure. Local toxic sensors are always connected to the Smart Sensor connector "S1" located on the back of the Display & Radio Assembly. (Local infrared combustible sensors are always connected to \_\_\_ on the Battery Board (See Fig.4-4).

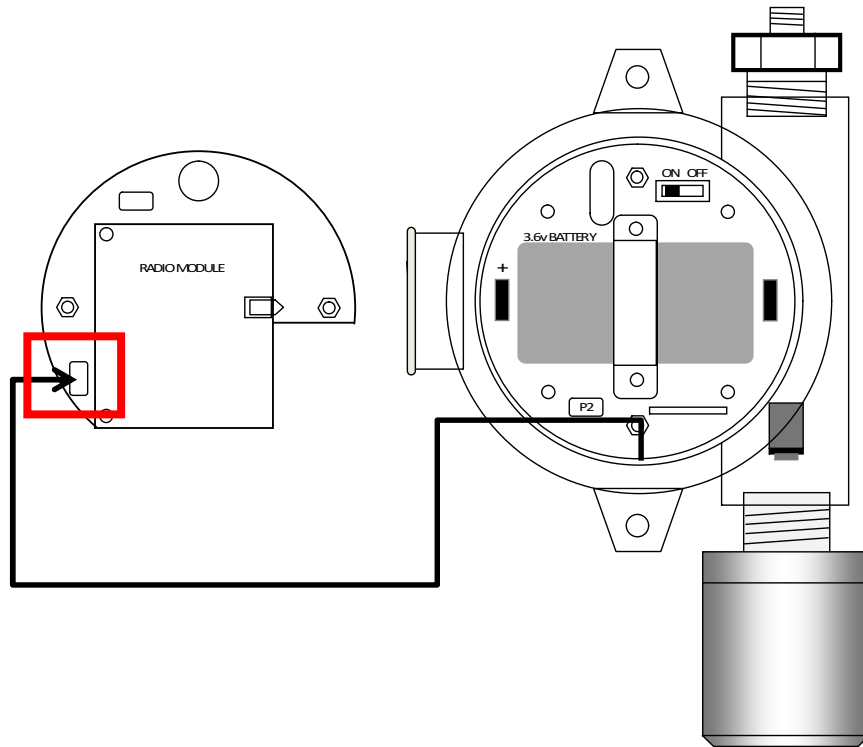

Figure 4-4: Local Smart Toxic Sensor

**IMPORTANT:** TOXIC SENSORS ARE SUBJECT TO ACCELERATED DETERIORATION IF POWER IS NOT SUPPLIED WITHIN 3 MONTHS OF SHIPMENT FROM GDS CORP.

### Connecting a Remote Sensor

GASMAX ECx monitors with remote-mount toxic sensors are shipped in two pieces and sensor wiring must be installed by the end user. Remote toxic sensors connect to the Simple Sensor input on the back of the Display / Radio Assembly as shown in Figure 4-6.

Due to the small signal output from toxic sensors, remote direct input toxic sensors should be mounted no more than 15 wire-feet from the GASMAX ECx display. Further, the cable used should be three-wire stranded with foil shield and should be run inside metallic rigid conduit. GDS Corp recommends Belden B8771. The cable shield must be connected to an earth ground at ONE END ONLY.

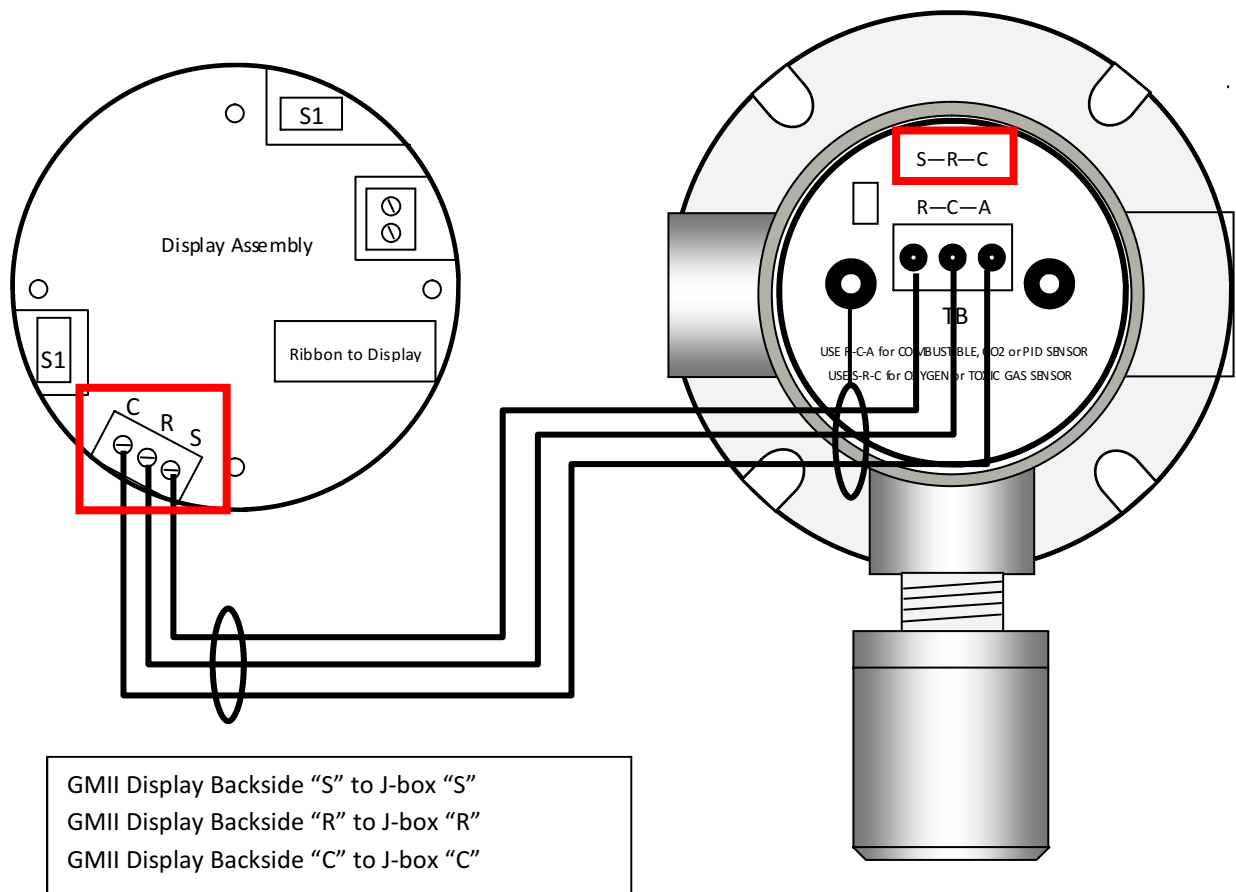
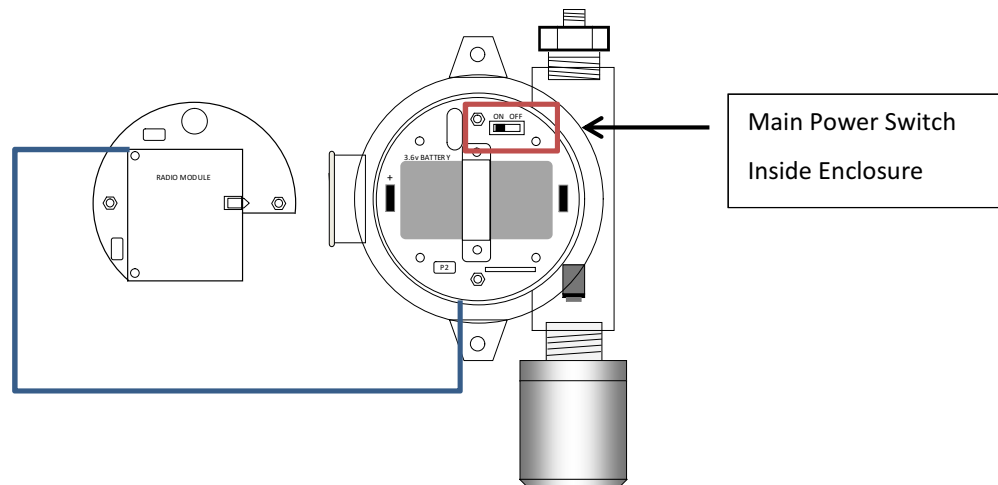

Figure 4-5: Remote Sensor Wiring

## Initial Setup

To access the Main Power switch, open the enclosure, loosen the two thumbscrews holding the display / radio module in place and move the display / radio module to the side. Set the Main Power switch to ON. Verify that the LCD display is active. Reinstall the display / radio module and enclosure cover. Certain sensors may initially indicate off-scale high or low values, but should quickly return to zero if no target gas is present.



**Figure 4-6: Main Power Switch**

**NOTE: DO NOT TURN THE GASMAX ECX ON UNTIL THE BEACON SIGNAL IS FULLY OPERATIONAL AND READY TO COMMUNICATE TO THE GASMAX ECX. BATTERY LIFE IS REDUCED IF THE GASMAX ECX IS ON FOR LONG PERIODS WHILE UNABLE TO COMMUNICATE TO THE MASTER CONTROLLER / RECEIVER.**

Once operational, the user should verify the following settings prior to initial calibration:

1. Local time and date: Check date value and adjust time for proper time zone (Sec. 6-5).
2. Tag name or Engineering Units settings: Edit values as necessary (Sec 6-2).
3. CAL SPAN GAS value: Set to match concentration of calibration gas cylinder (Sec 6-2).
4. CAL MARKER value: Adjust desired output mA during calibration (Sec 6-2).
5. ALARM 1, ALARM 2 settings: Set for desired levels. NOTE: GASMAX ECX programmable alarm levels affect operation of front panel LEDs only (Sec 6-3).

Allow the GASMAX ECX to stabilize prior to any initial calibration. Recommended sensor warm-up times are shown in Figure 3-2. This will allow the sensor to reach stable equilibrium with respect to environmental conditions such as ambient temperature, humidity, and barometric pressure as well as applied “reference” and “counter” voltages generated by the GASMAX ECX electronics. At this point, the GASMAX ECX can be calibrated and made operational.

## 5 CALIBRATION

### Calibration Overview

Calibration is critically important to ensure correct operation of the GASMAX ECX. The built-in CAL MODE function is designed to make calibration quick, easy and error free; a successful ZERO and SPAN calibration requires only four keystrokes.

When entering CAL MODE, the GASMAX ECx automatically transmits a data packet containing a gas value of 75 counts (-15.6% of scale) to enable properly programmed GDS Corp controller / receivers to indicate IN CAL for the current channel. Once CAL SPAN is complete, the GASMAX ECx transmits a data packet containing a value of 200 counts, indicating a 0% reading. However, if an oxygen sensor is detected, then the GASMAX ECx will transmit a data packet with a value of 869 counts (83.6% of scale) to simulate the typical 20.9% value found in atmospheric oxygen levels.

CAL MODE automatically exits if no keystrokes are detected after 5 minutes.

Follow these GASMAX ECX calibration guidelines:

- Calibration accuracy is only as good as the calibration gas accuracy. GDS Corp calibration gases are traceable to NIST (National Institute of Standards and Technology).
- **Never use calibration gas that has passed its expiration date.**
- Check the SPAN GAS VALUE setting and make sure it matches the calibration gas. (See Fig. 6-2)
- Always use a GDS Corp calibration cup that completely surrounds the sensor head.
- Be sure to use ZERO AIR, a mixture of 21% oxygen and 79% nitrogen, as a zero reference unless you are certain that no target gas exists in the area. Ambient gas may result in an 'elevated zero' condition that will cause a FAULT to occur once the ambient gas is no longer present.
- **Always calibrate a new sensor before depending on the device for personnel or equipment safety**
- Calibrate on a regular schedule. GDS Corp recommends a full calibration every 3 months, with periodic 'bump tests' on a more frequent basis to ensure that the sensor has not been affected by temperature extremes or the presence of incompatible gases.

### Calibration Procedure

Before beginning calibration, make sure you have the following items: A cylinder of calibration gas, fixed flow regulator and an appropriate calibration cup connected to the regulator via a length of flexible tubing. If necessary, a cylinder of 'zero air' may be necessary if the absence of target gas cannot be confirmed. GDS Corp recommends a flow rate of 0.5 liters / minute for standard gases and a flow rate of 1.0 liters / minute for highly reactive gases such as chlorine or chlorine dioxide.

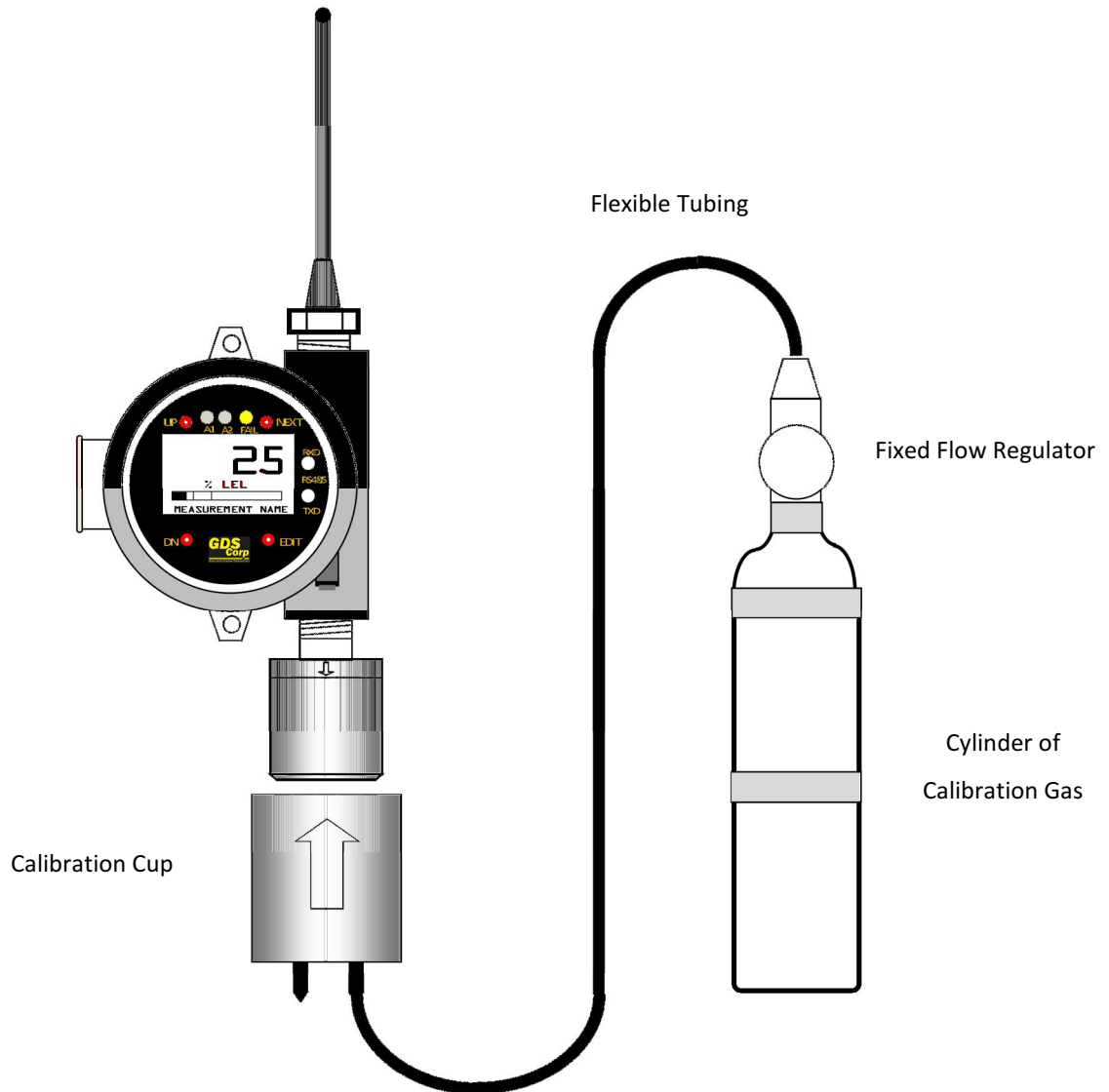

Figure 5-1: Calibration Setup

To calibrate a GASMAX ECx detector:

1. To enter CAL MODE, press the DOWN / CAL key and within 5 seconds press the EDIT key.
2. The screen will display an APPLY ZERO message. Using the setup shown in Fig. 5-1, apply clean ZERO air unless it can be guaranteed that no target gas is present. After the reading stabilizes, press the EDIT key to complete the ZERO calibration.
3. If the ZERO CAL SUCCESSFUL message is displayed, an APPLY SPAN message will appear. Apply the correct SPAN gas. After the reading is stable, (approximately 1 minute) press the EDIT key to complete the SPAN GAS calibration. If the SPAN calibration is successful, the display flashes REMOVE CAL GAS and starts the CAL PURGE delay.
4. Immediately shut off the regulator and remove the calibration cup. At the end of the CAL PURGE delay, the GASMAX EC output is re-enabled and the unit is fully operational.

The flow chart shown in Figure 5-2 illustrates the above procedure. UP, CAL, NEXT & EDIT labels indicate keystrokes using the magnetic wand. ZERO or SPAN calibration will fail if the readings exceed built-in limits for maximum allowable zero or minimum allowable span.

**NOTE: A CAL MODE INFO SCREEN IS AVAILABLE TO VIEW CERTAIN CAL MODE PARAMETERS DURING CALIBRATION. HOLD THE UP KEY FOR 5 SECONDS DURING CAL MODE TO DISPLAY THIS SCREEN.**

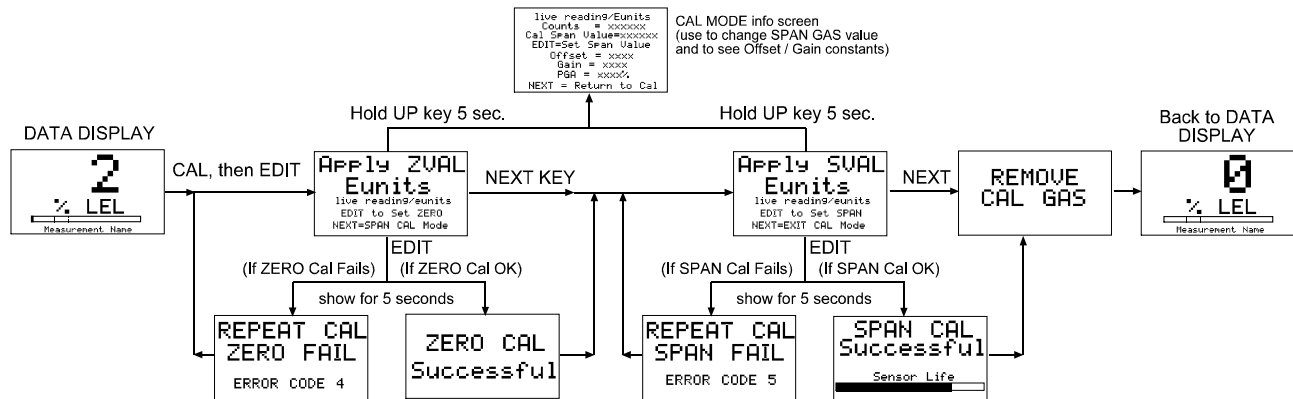

Figure 5-2: CALIBRATION FLOWCHART



## 6 OPERATION AND MAINTENANCE

### Normal Wireless Operation

Every six seconds, the onboard microprocessor initiates a sample sequence that measures the amount of gas present and broadcasts a data packet if the measured value exceeds the preset Alarm 1 level. In addition, the following actions will also result in a packet being transmitted:

- Every five minutes, irrespective of the gas level present. This allows controller / receivers to verify the presence of the gas monitor and issue a COMM ERROR if no transmission is received in a fixed interval (default is 18 minutes, but can be adjusted by the user).
- Upon entry into CAL mode, a packet containing a gas value of 75 counts (-15.6% of scale) is transmitted to enable properly programmed GDS Corp controller / receivers to indicate IN CAL for the current channel.
- Upon entry into CAL PURGE mode, a value of 200 counts (0% of scale) is transmitted for all sensors except oxygen sensors, where a value of 869 counts (83.6% of scale) is transmitted.
- Holding the magnetic wand over the UP key for more than 10 seconds will cause a transmission to occur that includes the most recent data.

### Alarm Operation – ALARM 1 and 2

GASMAX ECX's have front panel LED indicators for ALARM 1 and ALARM 2. Both alarm indicators can be set to activate above or below a given engineering units set point. Alarm processing will trigger an alarm condition when the input exceeds the programmed value, and includes hysteresis to keep the alarm from rapidly switching ON and OFF if the input remains close to the programmed alarm value.

**NOTE: GASMAX ECX ALARM 1 SETTING ESTABLISHES THE POINT AT WHICH THE GASMAX BEGINS TO TRANSMIT DATA ON 6 SECOND INTERVALS.**

**NOTE: GASMAX ECX ALARM 1 AND ALARM 2 SETTINGS DIRECTLY TRIGGER THE CORRESPONDING ALARMS ON THE GDS-98 WIRELESS SYSTEM MANAGER.**

### Alarm Operation – ALARM 3

ALARM 3 is typically used to indicate FAULT conditions that suggest sensor failure or “out of measurement range” conditions. However, some applications require a third level alarm. The ALARM 3 menu is identical to ALARM 1 and ALARM 2 and may be set to trip at any level.

**NOTE: ALARM 3 WILL ALSO TRIP WITH MISSING OR FAILED SENSORS REGARDLESS OF THE PROGRAMMED LEVEL VALUE.**

**NOTE: THE PRESENCE OF ALARM 3 WILL NOT CAUSE THE GASMAX ECX TO SWITCH INTO 6 SECOND RAPID TRANSMISSION MODE.**

## Sensor Replacement

If a sensor shows FAULT, does not respond to gas or can no longer be calibrated, it should be replaced.

GASMAX ECX monitors use GDS Corp type 10-95XX sensors, where the XX is the gas type shown in Section 3. The range value should also be specified when ordering replacement sensors. For example, a replacement H2S sensor for 0-100 ppm would be "10-9515-R0100".

To replace a sensor, review Fig. 6-2 and follow these steps (See Fig. 6-1):

1. Declassify the area or remove power to the GASMAX ECX.
2. Unscrew the sensor head cover. If unable to open the cover by hand, use a Sensor Head Replacement Tool (p/n 10-0187).
3. Remove the old sensor by pulling straight down.

**NOTE: DO NOT TRY TO UNSCREW THE SENSOR. PULL STRAIGHT DOWN.**

4. Carefully install the replacement sensor by aligning the arrow on the sensor with the arrow engraved on the sensor head. Push straight up until the sensor connector seats firmly into the sensor connector.
5. Reinstall the sensor head cover by CAREFULLY screwing the cover onto the sensor head.

**NOTE: IF THE SENSOR FALLS OUT OF THE SENSOR HEAD DURING THIS STEP, IT CAN BE DAMAGED. USE CAUTION WHEN REINSTALLING THE SENSOR HEAD COVER.**

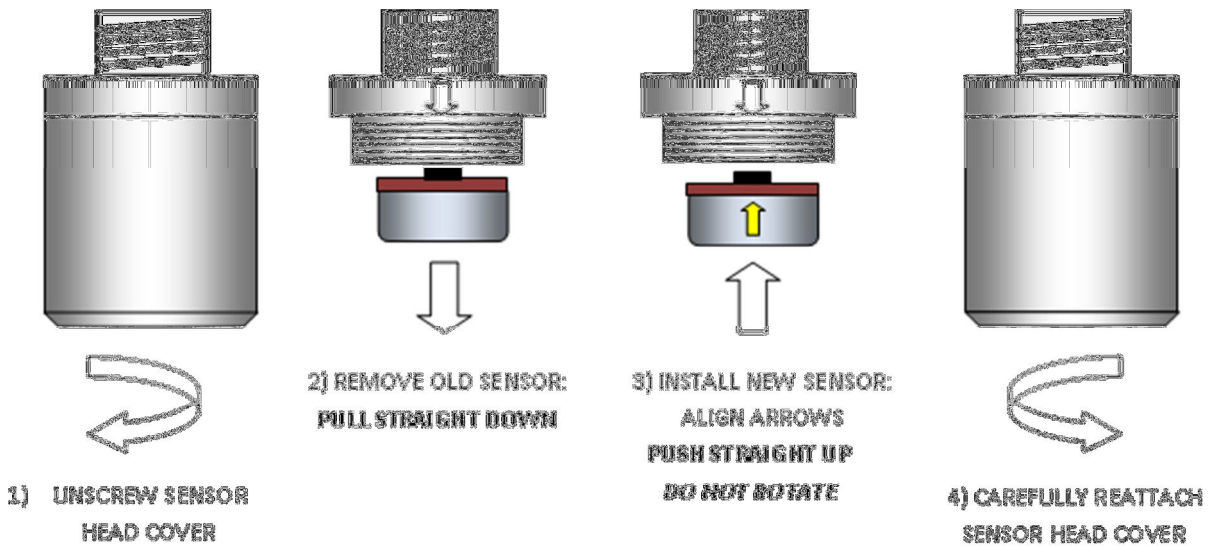

**Figure 6-1: Sensor Replacement**

Local Smart Sensors are automatically recognized by the GASMAX ECX and the Smart Sensor identification screen shown in Figure 6-1 (left side) should appear immediately after the installation of a local Smart

Sensor. If the sensor is the same gas type as was previously installed, the sensor's calibration data will be uploaded into the GASMAX ECX. All other parameters stored in the GASMAX ECX will be retained.

GASMAX ECX units can be reconfigured for different sensors by simply installing a different type compatible sensor. If a new sensor TYPE is installed, the Smart Sensor identification screen will appear, followed by the ERROR CODE 01 message and the user will be given the opportunity to confirm the new sensor type. If the user activates the EDIT key, all data stored in the new sensor's database – including range, tag name, cal span value, engineering units and alarm levels – will replace the current settings.

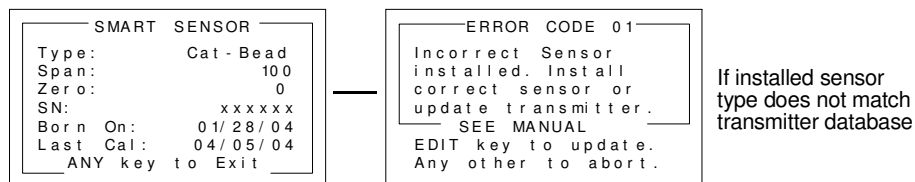

Figure 6-2: SMART SENSOR Recognition Screen

### Sensor Replacement – Remote Sensors

To replace a remote sensor, follow these steps:

1. Declassify the area or remove power to the GASMAX ECX.
2. Unscrew the remote sensor head cover. If unable to open the cover by hand, use a Sensor Head Replacement Tool (p/n 10-0187).
3. Remove the old sensor by pulling straight down.

**NOTE:** DO NOT TRY TO UNSCREW THE SENSOR. PULL STRAIGHT DOWN.

4. Carefully install the replacement sensor by aligning the arrow on the sensor with the arrow engraved on the sensor head. Push straight up until the sensor connector seats firmly into the sensor connector.

5. Reinstall the sensor head cover by CAREFULLY screwing the cover onto the sensor head.

**NOTE:** IF THE SENSOR FALLS OUT OF THE SENSOR HEAD DURING THIS STEP, IT CAN BE DAMAGED. USE CAUTION WHEN REINSTALLING THE SENSOR HEAD COVER.

6. At the GASMAX ECX, activate the Main Menu, open the Sensor Information page and select Install New Sensor. This will reset the Sensor Life settings and tell the GASMAX ECX that a new sensor is available.

NOTE: If the new sensor is of a different TYPE, a number of other settings, including input type, range, cal span value and others may have to be changed. Contact GDS Corp for more information.

### Normal Maintenance

Normal maintenance for the GASMAX ECx primarily involves battery replacement and periodic calibration on standard intervals. GDS Corp recommends calibration at least every three months, or more often if temperature extremes, vibration, the presence of incompatible gases or other environmental factors may accelerate the deterioration of the sensor element. Calibration should also include inspections for clogged or wet sensor heads, cracked or damaged enclosures and water incursion inside conduit or junction boxes.

## 7 USER MENUS

### Main Menu

GASMAX ECx setup variables are stored in non-volatile memory and can be modified by the end user to better match a particular application. The GASMAX ECX Main Menu tree is shown below. To access the Main Menu, swipe the magnetic wand over the EDIT key.

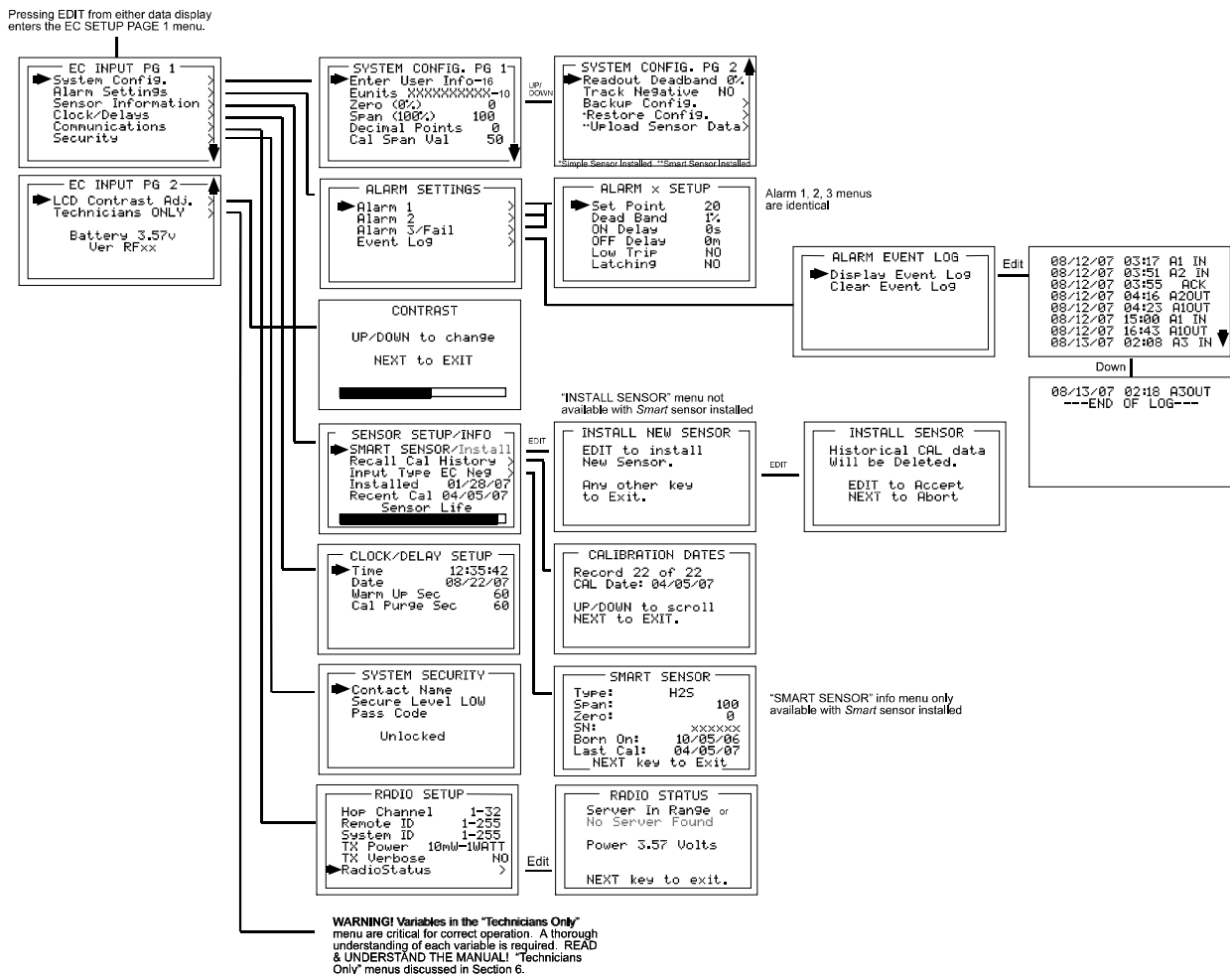

Figure 7-1: MAIN MENU FLOWCHART

## System Configuration Page

The System Config group consists of two pages of menus as shown in Figure 6-2. Each item's description follows in this section.

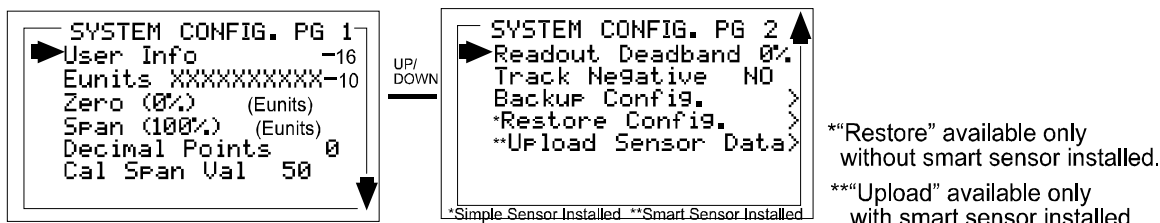

Figure 7-2: SYSTEM CONFIG MENU

**USER INFO** may be edited to contain virtually any 16-character field and is typically used to describe the monitored point by user tag number or other familiar terminology. To modify the existing setting, press the EDIT key when the cursor is pointing to the entry. Use the UP or DN keys to change the character, and the NEXT key to move to the next character. Press EDIT again when done.

**EUNITS** (engineering units) may have up to a 10 character ASCII field. Many common gases have pre-configured Eunits based upon the sensor type and each may be edited in this menu as described in Configuration Using the Magnetic Wand section 5-2.

**ZERO (0%)** defines the reading to be displayed when 4mA (0%) is the GASMAX ECX output.

**SPAN (100%)** defines the reading to be displayed when 20mA (100%) is the GASMAX ECX output. The highest reading allowed is 9999 including negative polarity sign. Polarity is only indicated for negative readings.

**DECIMAL POINTS** set the resolution of the LCD readings and may be set for 0, 1 or 2. For example, ZERO readings for 0, 1 & 2 decimal points displays as "0", "0.0" & "0.00".

**CAL SPAN VALUE** sets the engineering units value of the calibration gas. GDS Corp recommends that the calibration gas value be between 25% and 75% of full scale. Calibrating at 100% of scale is not recommended.

**READOUT DEADBAND** forces low values to continue to read zero. This is useful when there are small amounts of background gases that may cause fluctuating readouts. The highest amount of deadband allowed is 5%.

**TRACK NEGATIVE** allows the display to show negative values when set to "YES". This can be helpful when troubleshooting sensor problems. The default setting is "NO" and forces the display to read "0" if

the sensor value drops below zero. However, negative sensor outputs will always cause the Fault alarm to trip. The 4-20mA output always locks at 4mA when the reading drifts negative.

**BACKUP CONFIG** allows users to store the entire current GASMAX ECX menu database into non-volatile memory for restoration later if incorrect values are accidentally entered or uploaded.

**RESTORE CONFIG** restores the GASMAX ECX menu database to the values from the most recent Backup Config. This menu item is only available if a smart sensor is not installed. The special keystroke sequence of 4 consecutive UP keys is also required to perform backup and restore operations.

**UPLOAD SENSOR DATA** allows the user to manually upload the entire smart sensor database to the GASMAX ECX from the smart sensor.

### Alarm Settings Page

The Alarm Settings page covers the Alarm 1, 2, 3 Setup and Event Log menu items. Alarm 1, Alarm 2 and Alarm 3/Fail menus are identical and are therefore described only once in this section. For the GASMAX ECX, the alarm settings only affect the operation of the front panel LEDs. Separate alarm settings may need to be programmed in the 4-20mA receiving device.

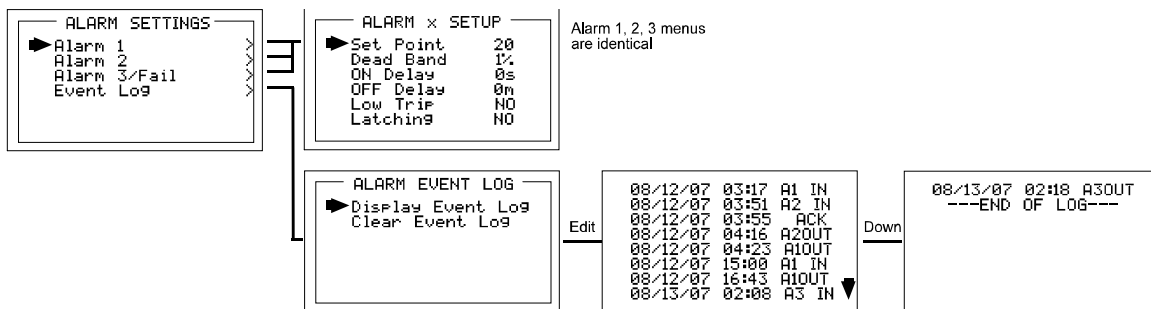

Figure 7-3: ALARM SETTINGS MENU

**SET POINT** enters the engineering unit value where the alarm trips. It may be negative and trip when monitored values fall out of range in this direction. A3 has a default setting of negative 10 with Low Trip set for YES. This makes it function as a FAULT alarm and trip when the monitored value falls to less than negative 10. It is important to adjust this value when the transmitter's span value is set for another value other than 100. For example, a typical span setting for monitoring oxygen level is 25 therefore the fault level value should be adjusted to -2.5 which is equal to negative 10% of full scale.

**DEAD-BAND** has a minimum value of 1% and a maximum value of 10%. It is useful for preventing alarm cycling when the monitored value is hovering around the set point. EXAMPLE: With a range of 0-100 ppm, if Dead-Band equals 5% and the set point is 20 ppm, after tripping at 20 ppm the value must drop below 15 ppm to reset.

**ON DELAY** allows entering a maximum 10 second delay before this alarm becomes active. This is useful for preventing nuisance alarms caused by brief spikes beyond the set point.

**OFF DELAY** allows entering a maximum 120 minute delay before clearing an alarm after the alarm condition is gone. This is useful for continuing an alarm function, such as operation of an exhaust fan, for a period of time after the alarm condition clears.

**LOW TRIP** set to YES causes the alarm to trip as the value falls below the set point.

**LATCHING** set to YES causes the alarm to remain active even after the condition is gone and only reset when the UP / RESET key is pressed from a data display.

**DISPLAY EVENT LOG** displays the stored events in the Event Log. These include power-on, cold-boot, alarms and alarm acknowledge events. The event log stores the date and time of the most recent 300 events.

**CLEAR EVENT LOG** clears the event log.

### Sensor settings page

The Sensor Information page covers settings associated with Smart or simple sensors. Users can review information contained in the Smart Sensor database, or adjust settings for remote simple sensors.

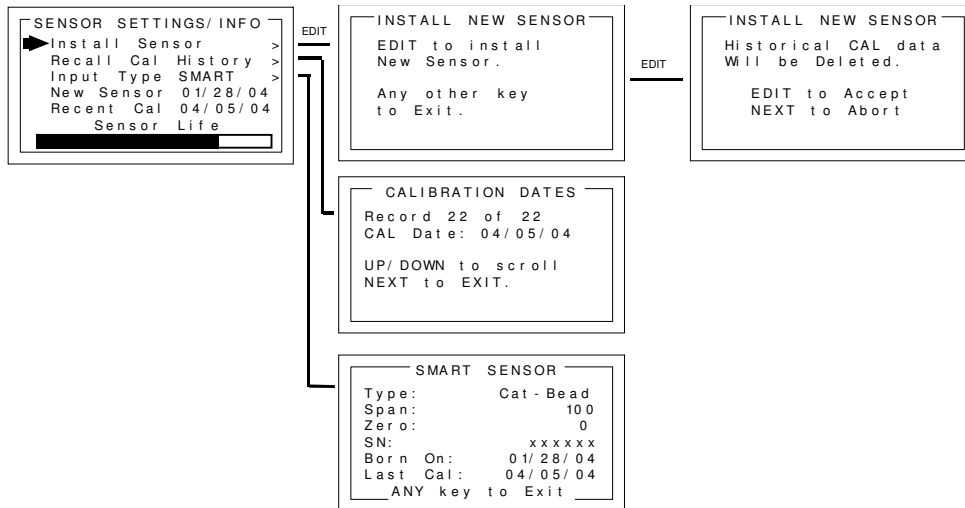

**Figure 7-4: SENSOR SETTINGS MENU**

**INSTALL NEW SENSOR** should always be performed when a new simple sensor is installed. This deletes historical CAL data and sets sensor life to 100% after initial calibration of the new simple sensor. The GASMAX ECX Smart Sensor interface will automatically detect new Smart Sensors and this menu is therefore not available with a Smart Sensor connected.

**RECALL CAL HISTORY** recalls each successful calibration. These dates may be reviewed by scrolling with the UP / DOWN keys.



**INPUT TYPE** indicates what kind of input or sensor the GASMAX ECX is configured to accept and is typically pre-configured at the factory. When installed, Smart Sensors upload sensor type and other data to the GASMAX ECX and this data may be viewed on the SMART SENSOR information screen.

**NEW SENSOR** displays the date when a new sensor was last installed.

**RECENT CAL** displays the most recent calibration date.

### Clock Delay Setup Page

The GASMAX ECX is equipped with a crystal-controlled, battery-backed real-time clock that maintains local Time and Date. These values are factory preset to US Central Time and should be reset to correctly match the current time zone during installation to make sure that time-stamped Event Log entries are correct.

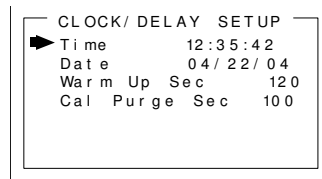

Figure 7-5: CLOCK DELAY MENU

**TIME** adjusts time of day in hours, minutes and seconds.

**DATE** adjusts date in month, day, year.

**WARM UP DELAY** sets the amount of time from power-on until the 4-20mA output signal begins to track the sensor output. Default setting is 60 seconds. Maximum value is 255 seconds.

**CAL PURGE DELAY** sets the amount of time from the completion of span calibration until the 4-20mA output signal restarts tracking the sensor output. The default setting is 60 seconds and the maximum value is 255 seconds.

### LCD Contrast Page

The LCD Contrast Adjustment allows the display to be set for optimum viewing.

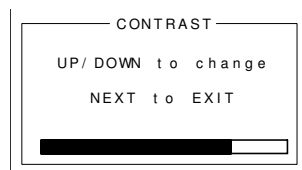

Figure 7-6: CONTRAST MENU

### System Security Page

The System Security menu offers two levels of protection against operation by unauthorized personnel or those with malicious intent.

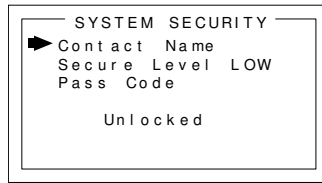

Figure 7-7: SYSTEM SECURITY MENU

**CONTACT NAME** is a 12 character ASCII field available for displaying a phone # or name of personal who knows the Pass Code. Lost Pass Codes may be recovered by entering the locked security menu and holding the UP key for 5 seconds. The 4-digit code appears near the bottom of the screen.

**SECURE LEVEL** sets LOW, HIGH or OFF modes. A LOW level allows CAL MODE sensor calibrations but requires the 4-digit Pass Code prior to altering menus. HIGH level locks the entire menu database and the CAL Mode until the correct Pass Code is entered. LOW and HIGH security levels always allow static viewing of configuration menus.

**Communications Setup Page**

The communications setup page allows the user to set hop channels, system ID and other RF-related variables.

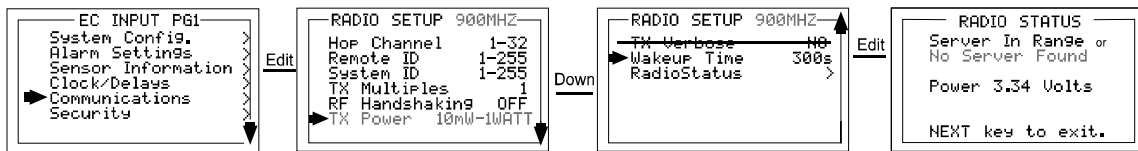

Figure 7-8: Communications Setup Page

**HOP CHANNEL** may be set from 1-32 (900 MHz) or 0-39 (2.4 GHz) and assigns the pseudo-random radio frequency hopping pattern. A transceiver will not go In Range of or communicate with a transceiver operating on a different Hop Channel. Different hop channels can be used to prevent radios in one network from listening to transmissions of another. Installations having more than one Server network should also have different hop channels for each network. For 2.4GHz radios, channels 0 to 19 represent channels in the EU “low band” range of 2.406 to 2.435 GHz, while channels 20 to 39 represent channels in the EU “high band” range of 2.444 to 2.472 GHz.

**REMOTE ID** may be set from 1-255 and acts as the “RTU” address for this particular GM ECx. Controller channels receiving this monitor’s data must also be configured with this matching Remote ID address.

**SYSTEM ID** may be set from 1-255 and is similar to a password character or network number and makes network eavesdropping more difficult. A transceiver will not go In Range of or communicate with a transceiver operating on a different System ID.

**TX MULTIPLES** allows up to 5 consecutive repeats of every transmission. The default settings is 1 and should be increased only if there is no other way to establish a reliable transmission link.

**RF HANDSHAKING** affects the way RF transmissions are made and may be set for OFF (default) or ON. OFF requires no acknowledge from the receiving server. ON **should be used only when transmitting to a single controller / receiver**. Since ON creates an “acknowledge” hand shake returned from the receiver, only one receiver is allowed to avoid data collisions of the “acknowledge” signal. If an “acknowledge” is not received by the GASMAX ECx, it transmits repeatedly up to 16 times.

**TX POWER** may be set for 10 mW, 200mW, 400mW and 1 watt for 900 MHz units and is fixed at 50 mW for 2.4 GHz units. Since GASMAX ECx monitors are battery powered the TX Power setting should be as low as possible to sustain reliable communication. The maximum TX Power setting is 30db (1 watt) and each time TX power is reduced by half, antenna transmit power is reduced by 3dB.

**TX VERBOSE** should be set to NO for normal operation.

**RADIO STATUS** opens another screen that shows if the GM ECx is In Range of the Server and what the battery power supply voltage is. Battery voltage is also displayed on the “EC INPUT PG. 2” screen shown in Figure 6-2.

## 8 TECHNICIANS MENUS

The TECHNICIANS MENU group consists of the TECHNICAL PAGE menu. This menu contains items that are typically factory configured depending upon the type sensor and input connected. Care should be used when modifying these variables as some items will prevent proper operation and could endanger personnel. Access requires a special key sequence of four UP keystrokes to prevent accidental modification of critical items.

### TECHNICAL PAGE Menu

The TECHNICAL PAGE menu is used to adjust certain parameters associated with local or remote sensors. To access the TECHNICAL PAGE menu, active the Main Menu, move the cursor to the second page and select Technicians Only. Enter the special key sequence to enter the TECHNICAL PAGE menu.

**WARNING: TARGET GAS MONITORING AND ALARM PROCESSING ARE NOT ACTIVE WHILE IN THIS MENU.**

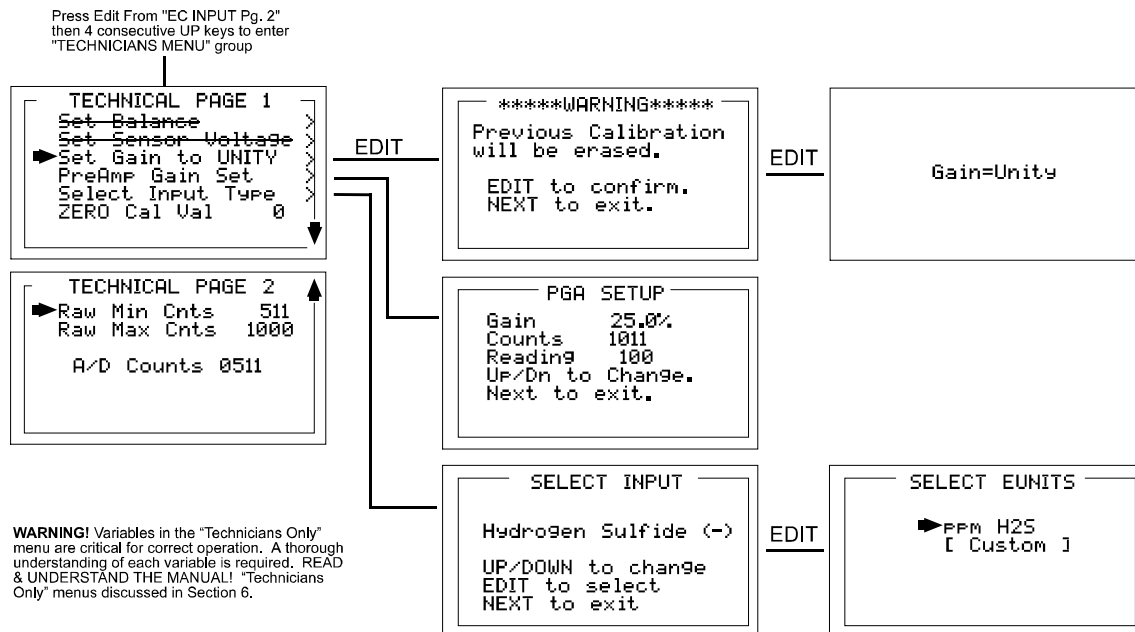

Figure 8-1: TECHNICAL PAGE MENU

**SET BALANCE** is for use with bridge-type sensors and is not available on the GASMAX ECX.

**SET VOLTAGE** is for use with bridge-type sensors and is not available on the GASMAX ECX.

**SET GAIN TO UNITY** clears any previous calibration OFFSET and GAIN values to "0.0" and "1.0",

respectively. This item is useful if a previous calibration was done in error, or if screen readings appear incorrect for no apparent reason.

**WARNING: A FULL CALIBRATION SHOULD ALWAYS BE PERFORMED AFTER A SET GAIN TO UNITY COMMAND.**

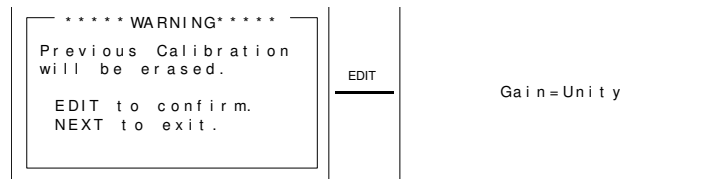
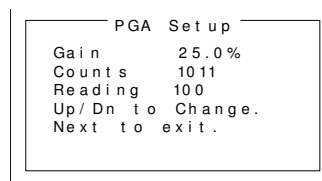

**Figure 8-2: SET GAIN TO UNITY MENU**

**PREAMP GAIN SET** allows adjustment of the analog amplifiers that match the sensor output to the optimum input range for the GASMAX ECX signal conditioning circuits. Local Smart Sensors include factory-preset preamp gain values and for standard sensors and applications, these values should not be changed.

For remote simple sensors or for situations where a local Smart Sensor does not quite provide enough signal to successfully complete a SPAN calibration, the Preamp gain can be adjusted using the UP / DOWN keys. GDS Corp does not recommend adjusting the Preamp Gain to any value higher than 85%.

**WARNING: A FULL CALIBRATION SHOULD ALWAYS BE PERFORMED AFTER ANY CHANGE IN THE PREAMP GAIN SETTING.**



**Figure 8-3: PREAMP GAIN SET MENU**

**INPUT TYPE** Local Smart Sensors automatically configure Input Type to match sensor requirements. However, when using remote sensors, Input Type must be set manually. Input Type is factory preset and should not be changed unless a different TYPE remote sensor is to be installed. Input Type configures GASMAX ECX hardware to accept bridge sensors, positive coefficient electrochemical sensors, negative coefficient electrochemical sensors or 4-20 mA inputs.

After selecting Input Type, a SELECT EUNITS screen indicates the default engineering units for this sensor.

Coefficient	Electrochemical Sensor Type	Default EUNITS
Negative	Hydrogen Sulfide	ppm H2S
Negative	Oxygen	% Oxygen
Negative	Carbon Monoxide	ppm CO
Negative, Bias	Ammonia	ppm NH3
Negative, Bias	Nitric Oxide	ppm NO
Negative	Ethylene Oxide	ppm Eth O2
Negative	Hydrogen Chloride	ppm HCL
Negative	Hydrazine	ppm N2H4
Negative	Arsine	ppm Arsine
Negative	Sulfur Dioxide	ppm SO2
Negative	Hydrogen	ppm H2
Negative	Hydrogen Cyanide	ppm HCN
Negative	Phosgene	ppm COCl2
Negative	Phosphine	ppm PH3
Negative	Hydrogen Fluoride	ppm HF
Positive	Nitrogen Dioxide	ppm NO2
Positive	Ozone	ppm Ozone
Positive	Chlorine	ppm Cl2

**ZERO CAL VALUE** should always be set to "0".

**RAW MIN / MAX COUNTS** is factory preset and should not be changed.

## 9 TROUBLESHOOTING GUIDE

### Toxic Sensor Indicates Fault or Overrange

- Certain toxic sensors indicate off-scale low or high at power up and quickly drift towards zero. This is normal behavior.
- Toxic sensors showing constant FAULT: If local, remove sensor and examine for moisture or discoloration. Replace sensor if wet or discolored. If remote, check sensor cable and junction box for moisture or standing water. Remove sensor and examine for moisture or discoloration. FAULT indication generally indicates sensor useful life is exhausted.
- Toxic sensors left unpowered for more than 3 months are subject to accelerated degradation and may demonstrate a permanent loss of sensitivity.

### Toxic Sensor Will Not Calibrate

- Sensor reading during zero calibration exceeds upper limit of zero – sensor is defective and should be replaced.
- Sensor reading during span calibration too low – sensor may be defective. However, it may be possible to temporarily continue operation by increasing PREAMP GAIN. See Section 8.2 for more details.

### Receiving Device and GASMAX Displayed Values Don't Match

- Check that zero and full scale range values match between GASMAX and receiving device (controller).
- Check to make sure the correct DATA FROM settings are in use at the Controller / receiver. This includes MODBUS type, MODBUS register, Device ID and MIN and MAX counts values.

### Controller Receiver shows Comm Error

- Hop Channel and / or System ID do not match radio setting.
- Device ID does not match channel Data From setting.
- Distance between gas monitor and controller / receiver too great for reliable communications
- Beacon signal failed or not enabled on controller / receiver / system manager
- Battery depleted.
- Antenna connection compromised or antenna broken.

### GASMAX Display Blank

- Verify main power switch set to ON.
- Verify battery not depleted.

### **GASMAX Error Codes**

- 01 – Incorrect sensor type – new sensor does not match most recent type of sensor. This is normal if changing sensor types. If unexpected, verify that new sensor type matches previous sensor type.
- 02 – Zero or span mismatch. Smart sensor zero or span values differ from those stored in the GASMAX.
- 03 – Sensor Calibration Error – Contact factory.
- 04 – Zero calibration failure – Zero readings must be within 10% of zero. For example, if the range is 0-100 ppm, the zero reading cannot be above 10 ppm. For bridge-type sensors, it may be possible to readjust the balance to restore a zero reading. Toxic sensors with high zero readings must be replaced.
- 05 – Span calibration failure – Span readings must be within a range of from  $\frac{1}{2}$  to 2x the target value. For example, if the target is 50 ppm, the sensor must output at least 25 ppm and no higher than 100 ppm at the current preamp gain setting for calibration to proceed.
- 06 – History data file full. Clear event log to remove.
- 07 – Sensor Channel Data CRC Fail – Error in sensor data transfer. Contact factory.
- 08 – System Data CRC Fail – Error in system data file. Contact factory.
- 09 – Custom Data CRC Fail – Error in system data file. Contact factory.
- 10- Linearization Data CRC Fail – Error in system data file. Contact factory.



## 10 SPARE PARTS

### Display & Enclosure

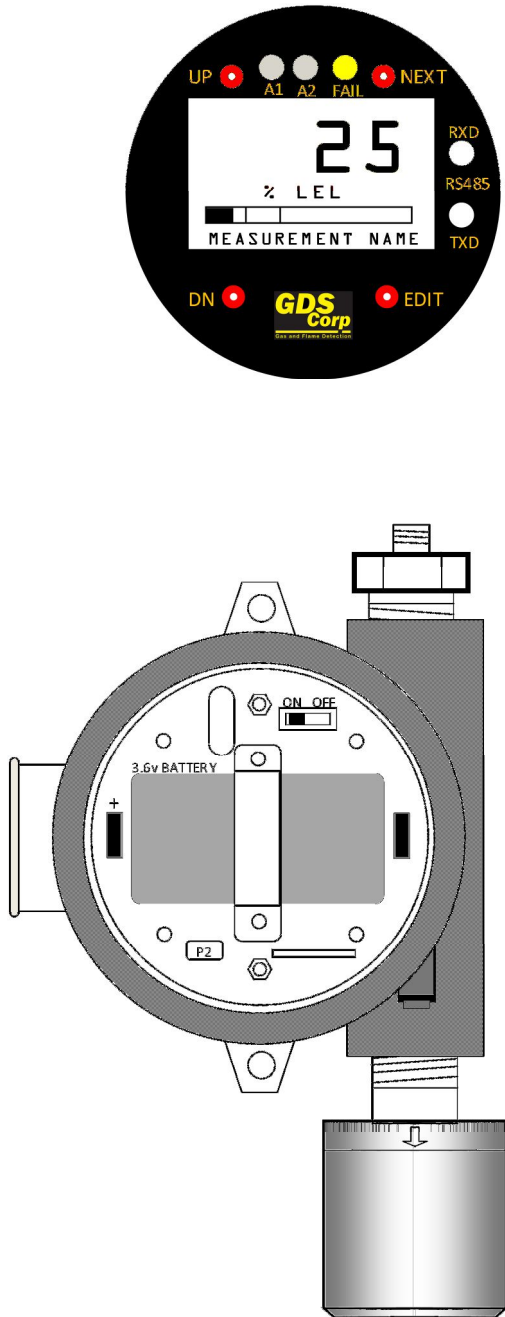

#### Display:

- 10-0232RF GASMAX Display (no radio)
- 10-0291 Replacement 900 MHz radio module
- 10-1360 Replacement 2.4 GHz radio module

#### Antenna Coupler:

- 10-0295 Standard antenna coupler (TNC connector)
- 1200-0482 Class 1 Div 1 rated antenna coupler

#### Components:

- 12-0099 Yellow Enclosure
- 10-0299 Battery / power supply board (inc cable)
- 10-0293 Replacement battery

#### Sensor Head Assembly:

- 10-0247 Sensor head for standard gases
  - 10-0247F Sensor head for reactive gases
- Note: Does not include sensor

Figure 10-1: GASMAX ECX + Local Sensor Spare Parts

**Sensor Head Accessories**

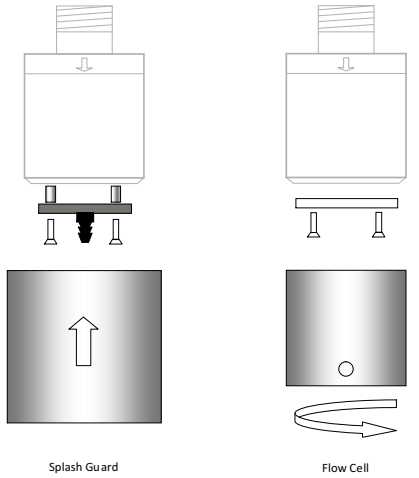

**Sensor Head Splash Guard**  
 10-0198 Splash Guard (Fits all sensor heads)

**Sensor Head Flow Cell**  
 10-0205 Flow Cell (1/8" NPT compression fittings)  
 20-0205S Other (specify)

**Figure 10-2: GASMAX Sensor Head Splash Guard & Flow Cell**

**Remote Sensor**

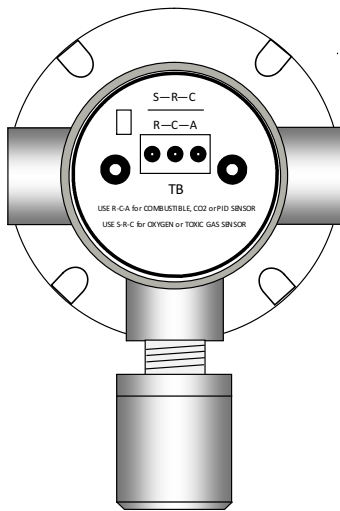

**Remote Sensor Head Assembly:**  
 20-0126 Remote Toxic or Bridge Direct (Type 5-6)  
 20-0127 Remote Toxic / Reactive Gas (Type 7-8)  
 Note: Does not include sensor

**Figure 10-3: GASMAX ECx Remote Direct Sensor Head**