

ML15F PA Horn Loudspeaker

The ML15F 15W PA loudspeaker is suitable for harsh environments with high ambient noise levels.

The ML15F features IP66 & IP67 (Type 4/4X) enclosures and re-entrant flare horns manufactured from high impact, fire retardant ABS. All models have dual cable entries and large termination areas containing in & out terminals.

Available with 70 and 100V line transformers or in 8 or 16 Ohm low impedance versions. The 70V line model is UL & cUL approved for Fire Alarm & Emergency and Professional & Commercial use for the US and Canada.

Features

- Continuously rated.
- Large termination area.
- Stainless steel fixings.
- Ratchet adjustable stainless steel 'U' bracket for 360° positioning.
- Duplicate cable terminations (in & out for daisy-chain installations).
- Tropicalisation available on request.
- Fire Alarm & Emergency and Professional & Commercial use.

Approvals

- UL 1480, Fifth Edition
CAN/ULC-S541-07
CSA C22.2 No. 205-12
UL category codes:
UUMW / UUMW7
UEAY / UEAY7
- EAC approved.
Cert: RU D-GB.AL16.V.11083
- Russian Maritime Register of Shipping
Cert: No. 14.02758.315
- CSFM listing: 7320-2279:0502



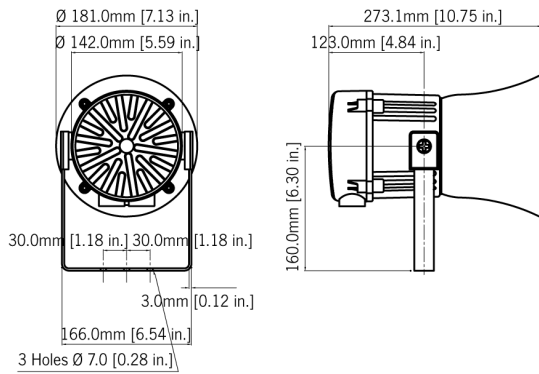

Specification

SPL:	108dB +/-3dB @ 1w @ 1m - Pink noise 118dB +/-3dB @ 15w @ 1m
Rated power:	15 Watts RMS
70v line tapings:	15w / 7.5w / 3w / 1w (z=336.67 Ohms / 653.33 Ohms / 1.6kOhms / 4.9kOhms)
100v line tapings:	15w / 7.5w / 3w / 1w (z=666.87 Ohms / 1.34kOhms / 3.34kOhms / 10kOhms)
Low impedance:	8 Ohm or 16 Ohm
Dispersion:	120° @ 1kHz & 32° @ 4kHz
Frequency range:	400Hz to 8000 Hz
DC Line monitoring:	2.2uF Capacitor (Transformer version) 470uF Capacitor (Low impedance version)
Ingress protection:	IP66 & IP67 (Third party tested) UL50E / NEMA250: 4 / 4X / 3R / 13
Housing material:	High impact UL94 V0 & 5VA FR ABS
Colour:	Grey (RAL7038) or Red (RAL3000)
Cable entries:	2 x M20; 1 x M20 & 1 x 1/2"NPT; 2 x 1/2"NPT supplied with 1 blanking plug
Terminals:	0.5 to 2.5mm ² cables.
Operating temp:	-40 to +66°C [-13° to +131°F]
Storage temp:	-40 to +70°C [-40° to +158°F]
Relative humidity:	90% at 20°C [68°F]
Weight:	70/100V line: 2.60kg/5.72lbs Low impedance: 2.20kg/4.84lbs
*SPL data +/-3dB(A). Measured at optimum voltage.	

Part Codes

Part Code:	Ident.:	Description:
Product type:	ML15	
Horn type:	F	Flare Horn
Type:	V100	100V Line
	V070	70V Line
	R008	8 Ohm Low impedance
	R016	16 Ohm Low impedance
Cable entries:	A	M20x1.5 & 1/2" NPT
	B	M20x1.5 & M20x1.5
	C	1/2" NPT & 1/2" NPT
Stopping plug material:	N	Nylon
Bracket:	1	304 (A2) Stainless Steel
	2	316 (A4) Stainless Steel
Approvals:	A1	CE, EAC, RMRS
	B1	UL, cUL
Enclosure:	R	Red
	G	Grey
*NOTE:	UL & cUL approval only available on 70V line version	