

MC1X05F Alarm Horn & Xenon Strobe

The MC1X05F combines a high output, 117dB(A) alarm sounder with a 5 Joule Xenon strobe beacon. Featuring a robust, fire retardant, IP66 & IP67 housing, the MC1X05F is particularly suitable for harsh environments with high ambient noise levels.

The flare horn on the MC1X05F produces sound level outputs up to 117dB(A) at 1 metre with a choice of 64 alarm tones and 4 remotely selectable stages. The Xenon strobe beacon automatically synchronises with other MC1X05F devices on the same power supply. The sounder & beacon can be operated individually or simultaneously.

Features

- Ingress protection IP66/67 Type 4/4X/13
- Glass lenses & 316 (A4) Stainless steel guard
- UV stable PC, field replaceable, colour lens filter
- Large termination area
- Dual M20 or 1/2"NPT cable entries – adaptors available
- Stopping plug included
- 316 (A4) Stainless steel mounting bracket
- Ratchet adjustable 'U' bracket for 360° positioning
- Duplicate cable terminations
- Reverse polarity diode fitted
- Continuously rated
- Automatic synchronisation
- 64 alarm tone frequencies and 4 remotely activated alarm stages
- Positive or negative stage activation switching
- Alternative activation configurations available
- Available with custom tone configurations and frequencies
- Alarm horn/sounder & beacon can be operated individually or simultaneously



Approvals

- EAC compliant: RU D-GB.GA05.B.12595-20
- Russian Maritime Register of Shipping
Cert: No. 19.00193.278



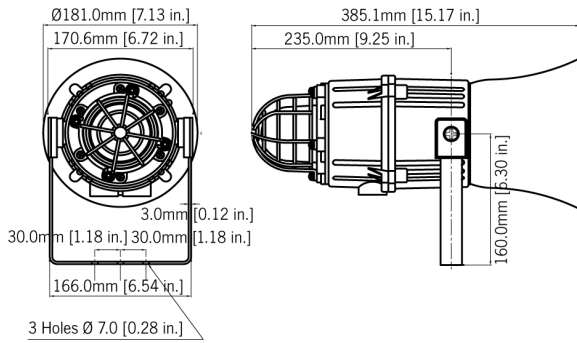

Specification

Alarm Horn Sounder:

Maximum output:	117dB(A) @ 1 m +/- 3dB [108dB(A) @ 10ft/3m +/- 3dB]
Nominal output:	114dB(A) @ 1m +/- 3dB [103dB(A) @ 10ft/3m] +/- 3dB
No. of tones:	64 (UK00A / PFEER compliant)
No. of stages:	4
Volume control:	Full range control
Effective range:	108m/355ft @ 1KHz
Stage switching:	Negative, positive, voltage free

Xenon Strobe Beacon:

Energy:	5 Joules(5Ws)
Flash rate:	1Hz (60 fpm)
Peak Candela:	500,000 cd - calculated from energy (J)
Eff. Intensity cd:	250 cd - calculated from energy (J)
Peak Candela:	39,463 cd* - measured ref. to I.E.S.
Eff. Intensity cd:	120 cd* - measured ref. to I.E.S.
Lens colours:	Amber, Blue, Clear, Green, Magenta, Red & Yellow

General:

Ingress protection:	IP66 & IP67 Type 4/4X/13
Enclosure material:	High impact UL94 V0 & 5VA FR ABS
Enclosure colour:	Grey (RAL7038) or Red (RAL3000)
Dome material:	Borosilicate glass
Lens colour filter:	Field replaceable UV stable PC
Lens guard:	316 (A4) Stainless steel
Cable entries:	2 x M20; 1 x M20 & 1 x 1/2"NPT; 2 x 1/2"NPT supplied with blanking plug
Terminals:	0.5 - 2.5mm ² (20-14 AWG)
Line monitoring:	Diode polarized for use in supervised circuits
Operating temp:	-40 to +66°C [-40° to +151°F]
Storage temp:	-40 to +70°C [-40° to +158°F]
Relative humidity:	95% at 20°C [68°F]
Weight :	DC: 3.00kg/6.6lbs AC:3.50kg/7.7lbs

*Candela measurements representative of performance with clear lens at optimum voltage

Part Codes

Variable:	Identifier:	Description:
Product type:	MC1X05	Combined alarm horn sounder & Xenon strobe
Type:	F	Flare re-entrant horn
Voltage:	AC115 AC230 DC012 DC024 DC048	115V ac 50/60Hz 230V ac 50/60Hz 12V dc (10-14Vdc) 24V dc (20-28Vdc) 48V dc (42-54Vdc)
Cable entries: [e]	A B C	M20x1.5 & 1/2" NPT M20x1.5 & M20x1.5 (Default) 1/2" NPT & 1/2" NPT
Stopping plug material: [m]	N	Nylon
Bracket & Guard: [s]	1 3	316 (A4) Stainless Steel 316 (A4) Stainless Steel with Equipment tag
Approvals:	A1	CE, EAC, RMRS
Enclosure: [x]	G R	Grey (RAL7038) Red (RAL3000)
Lens colour: [y]	A, B, C G, M, R, Y	Amber, Blue, Clear Green, Magenta, Red, Yellow
Accessories:	SP65-0001-A4 SP65-0002-A4	Pole Mount Bracket Kit 2" St/St A4 (316) Sunshade - St/St A4 (316)

Current Consumption

Product Version:	Nominal Voltage:	Voltage Range:	Beacon Current:	Horn Current:
DC012	12V dc	10-14V dc	550mA	280mA
DC024	24V dc	20-28V dc	300mA	224mA
DC048	48Vdc	42-54V dc	180mA	122mA
AC115	115Vac	±10% 50/60Hz	140mA	100mA
AC230	230V ac	±10% 50/60Hz	55mA	64mA

Tone table

S 1	Description	S 2	S 3	S 4	S 1	Description	S 2	S 3	S 4
T 1	1000 Continuous - PFEER Toxic Gas	T 3	T 2	T 44	T 33	800 (0.25s on, 1.00s off) Intermittent	T 53	T 24	T 8
T 2	1200/500 @ 1Hz Sweeping - DIN / PFEER P.T.A.P.	T 1	T 3	T 44	T 34	800 @ 2Hz (0.25s on, 0.25s off) - IMO code 3....	T 56	T 24	T 8
T 3	1000 @ 0.5Hz (1s on, 1s off) Intermittent - P...	T 1	T 2	T 44	T 35	1000 @ 1Hz (0.50s on, 0.50s off) Intermittent	T 44	T 24	T 8
T 4	1.4KH-1.6KHz 1s, 1.6KHz-1.4KHz 0.5s - NF C 48...	T 44	T 24	T 1	T 36	2400 @ 1Hz (0.50s on, 0.50s off) Intermittent	T 21	T 24	T 8
T 5	544(100mS)/440 (400mS) - NF S 32-001	T 52	T 19	T 1	T 37	2900 @ 5Hz (0.10s on, 0.10s off) Intermittent	T 53	T 24	T 8
T 6	1500/500 - (0.5s on, 0.5s off) x3 + 1s gap - ...	T 7	T 44	T 1	T 38	363/518 @ 1Hz (0.50s / 0.50s) Alternating	T 1	T 8	T 19
T 7	500-1500Hz Sweeping 2 sec on 1 sec off - AS4428	T 6	T 44	T 1	T 39	450/500 @ 2Hz (0.25s / 0.25s) Alternating	T 1	T 8	T 19
T 8	500/1200Hz @ 0.26Hz(3.3s on, 0.5s off) - NEN ...	T 44	T 24	T 35	T 40	554/440 @ 1Hz (0.50s / 0.50s) Alternating	T 44	T 24	T 19
T 9	1000 (1s on, 1s off)x7 + (7s on, 1s off) - IM...	T 18	T 34	T 1	T 41	554/440 @ 0.65Hz (0.76s / 0.76s) Alternating	T 1	T 8	T 19
T 10	1000 (1s on, 1s off)x7 + (7s on, 1s off) - IM...	T 21	T 34	T 1	T 42	561/760 @ 0.83Hz (0.60s / 0.60s) Alternating	T 1	T 8	T 19
T 11	420(0.5s on, 0.5s off)x3 + 1s gap - ISO 8201 ...	T 44	T 1	T 8	T 43	780/600 @ 0.96Hz (0.52s / 0.52s) Alternating	T 1	T 8	T 19
T 12	1000(0.5s on, 0.5s off)x3 + 1s gap - ISO 8201...	T 44	T 1	T 8	T 44	800/1000 @ 2Hz (0.25s / 0.25s) Alternating	T 5	T 24	T 19
T 13	422/775 - (0.85 on, 0.5 off) x3 + 1s gap - ...	T 44	T 1	T 8	T 45	970/800 @ 2Hz (0.25s / 0.25s) Alternating	T 1	T 8	T 19
T 14	1000/2000 @ 1Hz - Singapore	T 23	T 3	T 35	T 46	800/1000 @ 0.875Hz (0.57s / 0.57s) Alternating	T 53	T 24	T 19
T 15	300 Continuous	T 44	T 24	T 35	T 47	2400/2900 @ 2Hz (0.25s / 0.25s) Alternating	T 57	T 24	T 19
T 16	440 Continuous	T 44	T 24	T 35	T 48	500/1200 @ 0.3Hz (1.67s / 1.67s) Sweeping	T 44	T 24	T 12
T 17	470 Continuous	T 44	T 24	T 35	T 49	560/1055 @ 0.18Hz (2.73s / 2.73s) Sweeping	T 44	T 24	T 12
T 18	500 Continuous - IMO code 2 (Low)	T 44	T 24	T 35	T 50	560/1055 @ 3.3Hz (0.15s / 0.15s) Sweeping	T 44	T 24	T 12
T 19	554 Continuous	T 64	T 24	T 35	T 51	600/1250 @ 0.125Hz (4s / 4s) Sweeping	T 44	T 24	T 12
T 20	660 Continuous	T 44	T 24	T 35	T 52	660/1200 @ 1Hz (0.50s / 0.50s) Sweeping	T 64	T 24	T 12
T 21	800 Continuous - IMO code 2 (High)	T 44	T 24	T 35	T 53	800/1000 @ 1Hz (0.50s / 0.50s) Sweeping	T 56	T 24	T 12
T 22	1200 Continuous	T 44	T 24	T 35	T 54	800/1000 @ 7Hz (0.07s / 0.07s) Sweeping	T 57	T 24	T 12
T 23	2000 Continuous	T 15	T 3	T 35	T 55	800/1000 @ 50Hz (0.01s / 0.01s) Sweeping	T 54	T 24	T 12
T 24	2400 Continuous	T 48	T 20	T 35	T 56	2400/2900 @ 7Hz (0.07s / 0.07s) Sweeping	T 57	T 24	T 12
T 25	440 @ 0.83Hz (0.60s on, 0.60s off) Intermittent	T 1	T 44	T 8	T 57	2400/2900 @ 1Hz (0.50s / 0.50s) Sweeping	T 47	T 24	T 12
T 26	470 @ 0.9Hz (0.55s on, 0.55s off) Intermittent	T 1	T 44	T 8	T 58	2400/2900 @ 50Hz (0.01s / 0.01s) Sweeping	T 54	T 24	T 12
T 27	470 @ 5Hz (0.10s on, 0.10s off) Intermittent	T 1	T 44	T 8	T 59	2500/3000 @ 2Hz (0.25s / 0.25s) Sweeping	T 44	T 24	T 12
T 28	544 @ 1.14Hz (0.43s on, 0.44s off) Intermittent	T 44	T 24	T 8	T 60	2500/3000 @ 7.7Hz (0.65s / 0.65s) Sweeping	T 44	T 24	T 12
T 29	655 @ 0.875Hz (0.57s on, 0.57s off) Intermittent	T 1	T 44	T 8	T 61	800Hz Motor Siren	T 44	T 24	T 12
T 30	660 @ 0.28Hz (1.80s on, 1.80s off) Intermittent	T 44	T 24	T 8	T 62	1200Hz Motor Siren	T 44	T 24	T 12
T 31	660 @ 3.3Hz (0.15s on, 0.15s off) Intermittent	T 30	T 24	T 8	T 63	2400Hz Motor Siren	T 44	T 24	T 12
T 32	745 @ 1Hz (0.50s on, 0.50s off) Intermittent	T 44	T 24	T 8	T 64	Simulated Bell	T 44	T 21	T 12