



**The IS-DL105 combined sounder beacon is CE marked for compliance with the European Explosive Atmospheres Directive 94/9/EC and the European EMC Directive 89/336/EEC**

## 1) Introduction

The IS-DL105 is an ATEX and IECEx certified intrinsically safe combined sounder beacon which produces loud audible and bright visual warning signals in a hazardous area. Forty-nine first stage alarm sounds can be selected by internal switches and each one can be externally changed to a second or third stage alarm sound. The IS-DL105 combined sounder beacon also contains an alarm accept facility which allows an operator to silence the sounder for a predetermined time while leaving the beacon flashing or the sounder can be silenced after a predetermined time period has elapsed. The combined sounder beacon may be used in all gas groups IIA, IIB and IIC.

## 2) Ratings and Markings

### 2.1 ATEX/IECEx certification

The IS-DL105 sounder complies with the following standards:-

EN60079-0:2012/IEC60079-0:2011  
EN60079-11:2012/IEC60079-11:2011  
IEC60079-26:2014



II 1G Ex ia IIC T4 Ga (-40°C ≤ Ta ≤ +60°C)

The EC-Type Examination Certificate SIRA 04ATEX2302X has been issued by the Notified Body Sira. This confirms compliance with the European ATEX Directive 94/9/EC for Group II, Category 1G equipment. The sounder carries the Community Mark and subject to local codes of practice, may be installed in any of the EEA member countries. The product has also been approved to the IECEx scheme, Certificate no. IECEx SIR04.0039X. This instruction sheet describes installations which conform to EN60079-14:2008/IEC60079-14:2007 Electrical Installation in Hazardous Areas. When designing systems for installation outside the UK, the local Code of Practice should be consulted.

The certification marking is as follows:

- 1) The certificate number has an 'X' suffix, which indicates that the certificate contains one of more special conditions for safe use. Those installing or inspecting the equipment should refer to this section of the certificate.
- 2) The equipment has not been assessed as a safety-related device (as referred to by Directive 94/9/EC Annex II, clause 1.5).
- 3) Installation of this equipment shall be carried out by suitably-trained personnel in accordance with the applicable code of practice.
- 4) Repair of this equipment shall only be carried out by the manufacturer or in accordance with the applicable code of practice.
- 5) The certification of this equipment relies on the following materials used in its construction:

Enclosure: Aluminium Pressure Die Cast Body LM6  
Beacon enclosure: Borosilicate Glass  
Sealing of enclosure and mechanism: 'O' Ring

If the equipment is likely to come into contact with aggressive substances, then it is the responsibility of the user to take suitable precautions that prevent it from being adversely affected, thus ensuring that the type of protection is not compromised.

"Aggressive substances" - e.g. acidic liquids or gases that may attack metals, or solvents that may affect polymeric materials.

"Suitable precautions" - e.g. regular checks as part of routine inspections or establishing from the material's data sheet that it is resistant to specific chemicals.

### 2.2 Zones, Gas Groups and Temperature Classification

The IS-DL105 combined sounder beacon has been certified Ex ia IIC T4 Ga. When connected to an approved system it may be installed in:

- |        |   |
|--------|---|
| Zone 0 | explosive gas air mixture continuously present.   |
| Zone 1 | explosive gas air mixture likely to occur in normal operation.                                      |
| Zone 2 | explosive gas air mixture not likely to occur, and if it does, it will only exist for a short time. |

### Be used with gases in groups:

- |           |          |
|-----------|----------|
| Group IIA | propane  |
| Group IIB | ethylene |
| Group IIC | hydrogen |

### Having a temperature classification of:

- |    |       |
|----|-------|
| T1 | 450°C |
| T2 | 300°C |
| T3 | 200°C |
| T4 | 135°C |

### 3) Installation Requirements

#### SPECIAL CONDITIONS FOR SAFE USE (As per ATEX/IECEx Certification).

The equipment has an ingress protection rating of IP66. However, if it has been supplied without cable entry devices, then the user shall ensure that the devices that are fitted will provide an ingress protection that is appropriate to the environment in which it is installed i.e. IP20 or better. If only one of the two cable entries are used, then the unused entry shall be fitted with a blanking device that ensures ingress protection appropriate to the environment in which it is installed i.e. IP20 or better.

The enclosure may be manufactured from cast aluminium. In rare cases, ignition sources due to impact and friction sparks could occur. This shall be considered during installation, particularly if the equipment is installed in an area requiring Equipment Protection Level Ga.

When the IS-DL105 Sounder/Beacon is powered via two separate barriers, they shall be installed as separate intrinsically safe circuits; the Sounder shall not be electrically connected to the Beacon and they shall not share a common return line.

#### 3.1 Terminals + and -

Power is supplied to the combined sounder beacon via the + and - terminals which have the following input safety parameters:

	Wired to Sounder / Beacon Combined	Wired To Beacon Only
<b>Ui</b>	28V	28V
<b>Ii</b>	93mA	660mA
<b>Pi</b>	660mW	1.2W
<b>Ci</b>	0mA	0mA
<b>Li</b>	0mA	0mA

Table 1.0

The IS-DL105 combined sounder beacon may be powered from an ATEX certified Zener barrier which has output parameters equal to or less than 28V, 93mA/660mA or galvanic isolator. If using separate barriers for the sounder and beacon the cable parameters stated on the selected Zener barrier or galvanic isolator certificate must be observed.

Up to three IS-DL105 combined sounder beacons can be connected in parallel and powered from a common barrier or isolator. Connecting two combined sounder beacons in parallel will reduce the output from each by about 3dB. Three sounder should only be powered from a common supply when the maximum supply voltage is available.

#### 3.2 Terminals S2 and S3

When terminals S2 or S3 are connected to 0V (- terminal) the combined sounder beacon output tone changes to the second or third stage alarm tone respectively. The input safety parameters for these terminals are:

Ui	=	28V
Ii	=	0mA

Because the permitted input current is zero, these terminals may only be connected to a diode return barrier, an intrinsically safe relay or a galvanic isolator, all of which must have been certified by an EC Notified Body. Only diode return barriers with a voltage drop of less than 0.9V may be used. Alternatively, these terminals may be connected

directly to a mechanically activated switch within the hazardous area.

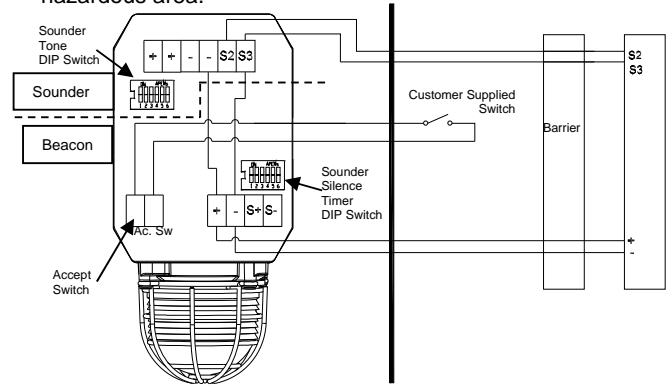

Fig 1 Simplified Block Wiring Diagram.

#### 3.3 Description

Fig 1 shows a simplified block diagram of an IS-DL105 unit. The device operates immediately when power is applied to the + and - terminals. The output tone is defined by the positions of the six internal switches and this tone can be changed to a second or third stage alarm tone by connecting terminals S2 or S3 to 0V. The tone generator is crystal controlled to ensure that when two sounders are started at the same time the output tones remain synchronised. The sounder may be silenced for a predetermined time by momentarily connecting the Ac.Sw terminals together. The silence time is set by DIP switches 1 to 4 for time periods between 5 seconds and 2 hours. **By setting DIP switch 5 to ON the sounder will silence after a preset time, but sound will not be restored until the power to the beacon has been removed and restored.** Setting DIP switch 6 to ON will provide a 1 second reminder beep tone sound while the sounder is silenced. The interval between the 1 second reminder beep is dependent on the timing setting for the silence period, (switches 1 to 4) see page 5. The beacon produces two flashes in quick succession once per second. When the sounder is silenced the flash frequency is automatically doubled.

#### 3.4 Supply Voltage

The IS-DL105 unit has been designed to operate in a hazardous area via a 93mA 660mW resistive ATEX and IECEx certified Zener Barriers or Galvanic Isolators. The unit may be tested or used in safe areas without a Zener barrier or galvanic isolator, but at supply voltages above 16V the internal current limit will function and the brightness may be reduced. The unit should not be operated continuously with a direct supply greater than 16V.

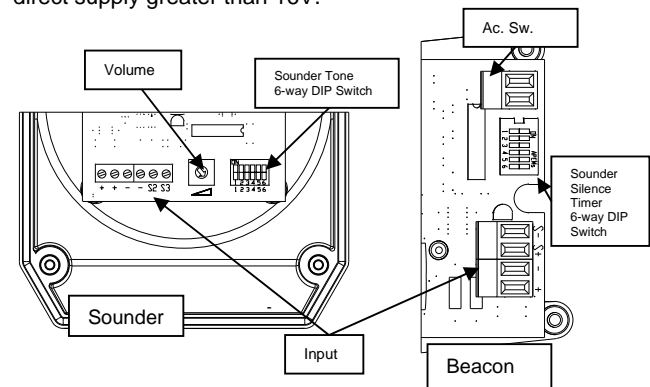

Fig 2 Location of field terminals and controls.

#### 4) Installation

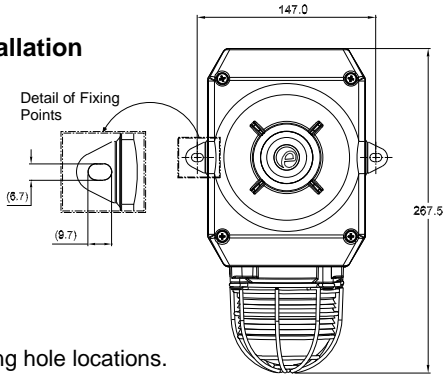

Fig 3 Fixing hole locations.

IS-DL105 combined sounder beacons should only be installed by trained competent personnel.

#### 4.1 Mounting

The IS-DL105 combined sounder beacon may be secured to any flat surface using the two M6, 147mm pitch fixing holes. The enclosure provides IP66 protection and is suitable for installation in exterior locations providing it is positioned so that water cannot collect in the horn, and the cable entry is sealed.

#### 4.2 Installation procedure

- Secure the IS-DL105 combined sounder beacon to a flat surface via the two M6, 147mm pitch fixing holes in the mounting feet.
- Remove the front of the combined sounder beacon by unscrewing the four captive cover screws and pulling the front away from the enclosure.
- Remove the PVC grommet and fit a M20 x 1.5 cable gland or conduit entry into the hole in the enclosure and connect the field wiring to the appropriate combined sounder beacon terminals as shown in sections 5 & 6 and fig 2 of this manual. The power supply terminals + and - are duplicated so that combined sounder beacons may be connected in parallel, or an end of line monitoring resistor may be fitted.
- Select the required sounder output tone by positioning the 6-way DIP switch as shown in Table 2.0 and Fig 2.
- If required, set sounder silence timer delay using the 6-way DIP switch as shown in Table 3.0 and Fig 2.
- Apply power to the combined sounder beacon and adjust the internal volume control to provide the required sound level
- Replace the front of the combined sounder beacon and tighten the four captive cover screws.

#### 5) Electrical System Design For Installation In Hazardous Areas Using Zener Barriers

When powering both sections through a common barrier, the max ratings for the sounder only applies. In order that the beacon continues to produce a reasonable light output level the power supply voltage to the barrier should be maintained at a minimum of 18V.

The IS-DL105 combined sounder beacon provides both a visual and an audible warning via a common barrier and therefore the sound output is reduced by about 2dB compared to IS-D105 sounder only unit.

The IS-DL105 combined sounder beacon contains a circuit that will silence the sounder for a pre-set time, but leave the beacon flashing at twice its normal frequency. The sounder silence time is set by internal DIP switches on the beacon

section. An operator may therefore silence the audible alarm but be continuously reminded of the alarm condition by the beacon. If the alarm is not cleared within the silence time, the sounder will be reactivated. If the alarm is cleared during the silence time the beacon will stop flashing, but the beacon and the sounder will both be re-activated if the alarm reoccurs. See table 3.0 on page 6 of these instructions for full DIP switch settings.

The silence accept push-button (Ac. Sw) may be any mechanically operated switch, providing it has an IP protection suitable for the environmental conditions to which it is subjected, located within the same hazardous area as the beacon, see section 3.2.

The control arrangement will vary depending upon the isolator chosen.

#### 5.1 Single stage alarm

If the control switch is in the positive supply, or the power supply is being turned on and off, only a single channel Zener barrier is required as shown in Fig 4. This circuit may also be used if the combined sounder beacon is being controlled by a mechanically activated switch on the hazardous area side of the barrier.

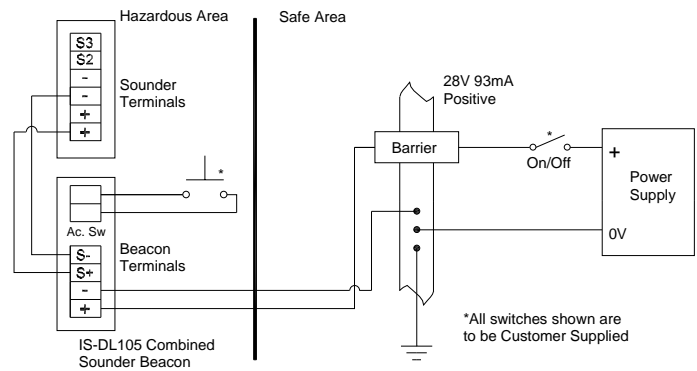

Fig 4 Single stage alarm using single channel barrier.

If the control switch must be in the negative supply, the circuit shown in Fig 5 may be used. Any diode return barrier certified Ex ia by a EC Notified Body may be used, providing its voltage drop is less than 0.9

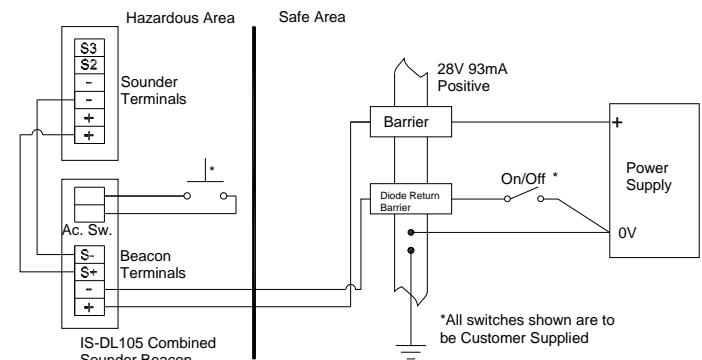

Fig 5 Single stage alarm using two channel barrier.

### 5.2 Multi-stage alarm

Connecting terminal S2 to 0V activates the second stage alarm, and similarly terminal S3 for the third stage alarm. Fig 6 shows how the diode return barriers may be used. If only two stages of alarm are required the third stage barrier should be omitted, the 28V 93mA barrier and the single diode return channel may then be contained in one package.

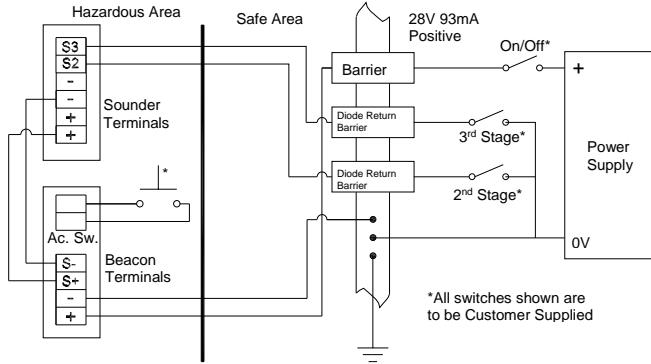

Fig 6 Multi stage alarm using Zener barriers.

### 5.3 Separate Zener Barriers

The Sounder and Beacon sections of the combined unit can be powered via separate Zener Barriers if the pre-installed red and black wires running between the two sections are removed. Please refer to Table 1.0 max ratings.

Provided that the power supplied to the Zener Barriers is maintained at a minimum of 18V, up to three IS-DL105 units can be connected when using separate Zener Barriers for the beacon and sounder sections of the units.

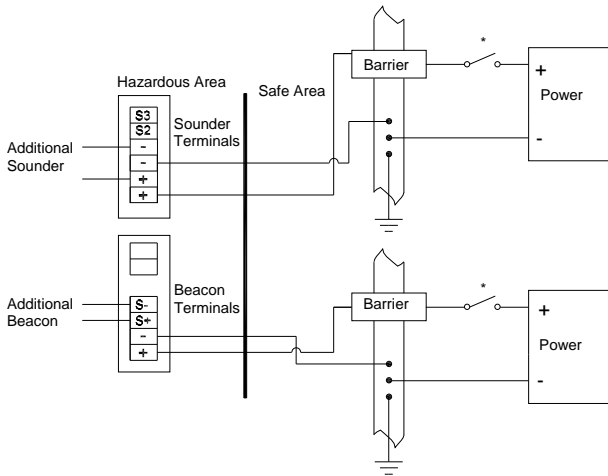

Fig 7 Separate Zener barriers for Sounder And Beacon Sections

## 6) Electrical System Design For Installation In Hazardous Areas Using Galvanic Isolators

Galvanic isolators although more expensive than Zener barriers, do not require a high integrity earth connection. For small systems where a high integrity earth is not already available, the use of galvanic isolators often reduces the overall installation cost and simplifies design.

The galvanic isolator must be able to supply an output of 30mA at about 16V. This circuit may also be used if the beacon is controlled by a mechanically activated switch on the hazardous area side of the isolator.

### 6.1 Single stage alarm

The IS-DL105 combined sounder beacon may be powered by any galvanic isolator having output parameters within the limits specified in section 3.1, which has been certified Ex ia by an EC Notified Body. The combined sounder beacon may be controlled by turning the galvanic isolator on and off, or by a mechanically activated switch on the hazardous area side of the isolator.

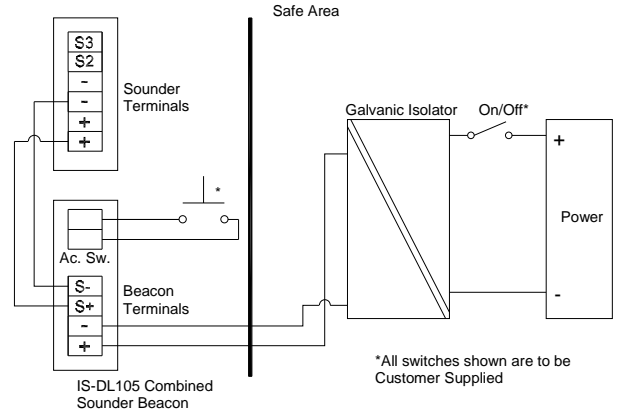

Fig 8 Single stage alarm using galvanic isolator.

### 6.2 Multi stage alarm

The IS-DL105 combined sounder beacon second and third stages may be activated by using Galvanically Isolated Relays that have output parameters within the limits specified in section 3.2, which have been certified Ex ia by an EC Notified Body.

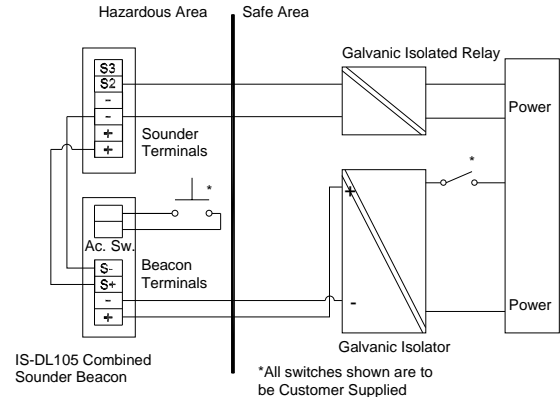

Fig 9 Multi stage alarm using galvanic isolated relays

### 6.3 Separate Galvanic Isolators

The Sounder and Beacon sections of the combined unit can be powered via separate Galvanic Isolators if the pre-installed red and black wires running between the two sections are removed. Please refer to Table 1.0 max ratings.

The that the Galvanic Isolators are able to supply an output of 30mA at about 16V, up to three IS-DL105 units can be connected when using separate Galvanic Isolators for the beacon and sounder sections of the units.

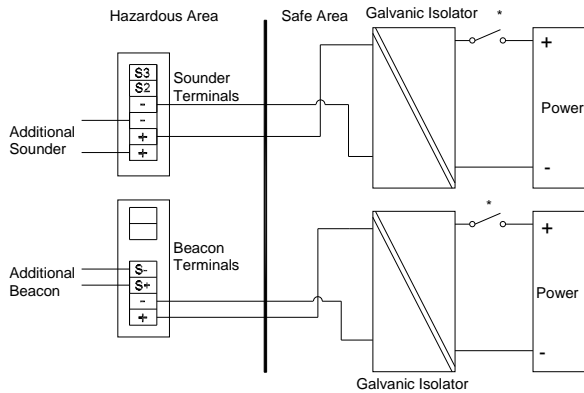

Fig 10 Separate Galvanic Isolators For Sounder And Beacon Sections.

### 7) Cable parameters

The maximum permitted cable parameters are as specified on the certificate of the Zener barrier or galvanic isolator that has been selected for the installation. Normally the limits are not restrictive, but care should be taken not to exceed a capacitive limit of 83nF for installations when very long cables are used.

### 8) Volume Control

The output level of the IS-DL105 combined sounder beacon can be set by adjusting the volume control potentiometer (see Fig 2).

**Tone Selection** – To select the required first stage tone set the tone switches 1 to 6 (see Fig 2) to the tone setting shown in the table below. The table also shows which 2<sup>nd</sup> and 3<sup>rd</sup> stage tones are available for use with the selected first stage tone if more than one tone output stage is required.

Table 2.0

Tone Number	Tone Description	Switch Settings	Second Stage Alarm	Third Stage alarm
		1 2 3 4 5 6		
Tone 1	Continuous 340Hz	0 0 0 0 0 0	Tone 2	Tone 5
Tone 2	Alternating 800/1000Hz @ 0.25s intervals	1 0 0 0 0 0	Tone 17	Tone 5
Tone 3	Slow whoop 500/1200Hz @ 0.3Hz with 0.5s gap repeated	0 1 0 0 0 0	Tone 2	Tone 5
Tone 4	Sweeping 500/1000Hz @ 1Hz	1 1 0 0 0 0	Tone 6	Tone 5
Tone 5	Continuous 2400Hz	0 0 1 0 0 0	Tone 3	Tone 20
Tone 6	Sweeping 2400/2900Hz @ 7Hz	1 0 1 0 0 0	Tone 7	Tone 5
Tone 7	Sweeping 2400/2900Hz @ 1Hz	0 1 1 0 0 0	Tone 10	Tone 5
Tone 8	Siren 500/1200/500Hz @ 0.3Hz	1 1 1 0 0 0	Tone 2	Tone 5
Tone 9	Sawtooth 1200/500Hz @ 1Hz - <i>D.I.N.</i>	0 0 0 1 0 0	Tone 15	Tone 2
Tone 10	Alternating 2400/2900Hz @ 2Hz	1 0 0 1 0 0	Tone 7	Tone 5
Tone 11	Intermittent 1000Hz @ 1Hz	0 1 0 1 0 0	Tone 2	Tone 5
Tone 12	Alternating 800/1000Hz @ 0.875Hz	1 1 0 1 0 0	Tone 4	Tone 5
Tone 13	Intermittent 2400Hz @ 1Hz	0 0 1 1 0 0	Tone 15	Tone 5
Tone 14	Intermittent 800Hz 0.25s ON, 1s OFF	1 0 1 1 0 0	Tone 4	Tone 5
Tone 15	Continuous 800Hz	0 1 1 1 0 0	Tone 2	Tone 5
Tone 16	Intermittent 660Hz 150Ns ON, 150ms OFF	1 1 1 1 0 0	Tone 18	Tone 5
Tone 17	Alternating 544Hz (100ms) / 440Hz (400ms) – <i>NFS 32-001</i>	0 0 0 0 1 0	Tone 2	Tone 27
Tone 18	Intermittent 660Hz 1.8s ON, 1.8s OFF	1 0 0 0 1 0	Tone 2	Tone 5
Tone 19	Sweep 1400Hz to 1600Hz up 1s 1600Hz to 1400Hz down 0.5s	0 1 0 0 1 0	Tone 2	Tone 5
Tone 20	Continuous 660Hz	1 1 0 0 1 0	Tone 2	Tone 5
Tone 21	Alternating 554/440Hz @ 1Hz	0 0 1 0 1 0	Tone 2	Tone 5
Tone 22	Intermittent 544Hz @ 0.875Hz	1 0 1 0 1 0	Tone 2	Tone 5
Tone 23	Intermittent 800Hz @ 2Hz	0 1 1 0 1 0	Tone 6	Tone 5
Tone 24	Sweeping 800/1000Hz @ 50Hz	1 1 1 0 1 0	Tone 29	Tone 5
Tone 25	Sweeping 2400/2900Hz @ 50Hz	0 0 0 1 1 0	Tone 29	Tone 5
Tone 26	Simulated bell	1 0 0 1 1 0	Tone 2	Tone 15
Tone 27	Continuous 554Hz	0 1 0 1 1 0	Tone 26	Tone 5
Tone 28	Continuous 440Hz	1 1 0 1 1 0	Tone 2	Tone 5
Tone 29	Sweeping 800/1000Hz @ 7Hz	0 0 1 1 1 0	Tone 7	Tone 5
Tone 30	Continuous 300Hz	1 0 1 1 1 0	Tone 2	Tone 5
Tone 31	Sweeping 660/1200 @ 1Hz	0 1 1 1 1 0	Tone 26	Tone 5
Tone 32	Two Tone Chime	1 1 1 1 1 0	Tone 26	Tone 15
Tone 33	Intermittent 745Hz	0 0 0 0 0 1	Tone 2	Tone 5
Tone 34	Alternating 1000/2000Hz @ 0.5s – <i>Singapore</i>	1 0 0 0 0 1	Tone 38	Tone 45
Tone 35	420Hz @ 0.625s - <i>Australian Alert</i>	0 1 0 0 0 1	Tone 36	Tone 5
Tone 36	500-1200Hz 3.75s / 0.25s - <i>Australian Evacuate</i>	1 1 0 0 0 1	Tone 35	Tone 5
Tone 37	Continuous 1000Hz	0 0 1 0 0 1	Tone 9	Tone 45
Tone 38	Continuous 2000Hz	1 0 1 0 0 1	Tone 34	Tone 45
Tone 39	Intermittent 800Hz 0.25s ON 1s OFF	0 1 1 0 0 1	Tone 23	Tone 17
Tone 40	Alternating 544Hz (100ms) / 440Hz (400ms) – <i>NFS 32-001</i>	1 1 1 0 0 1	Tone 31	Tone 27
Tone 41	Motor Siren – Slow rise to 1200Hz	0 0 0 1 0 1	Tone 2	Tone 5
Tone 42	Motor Siren – Slow rise to 800Hz	1 0 0 1 0 1	Tone 2	Tone 5
Tone 43	Continuous 1200Hz	0 1 0 1 0 1	Tone 2	Tone 5
Tone 44	Motor Siren – Slow rise to 2400Hz	1 1 0 1 0 1	Tone 2	Tone 5
Tone 45	Intermittent 1000Hz 1s ON, 1s OFF	0 0 1 1 0 1	Tone 38	Tone 34
Tone 46	Sawtooth 1200/500Hz @ 1Hz - <i>D.I.N. (PFEER P.T.A.P)</i>	1 0 1 1 0 1	Tone 47	Tone 37
Tone 47	Intermittent 1000Hz 1s ON, 1s OFF – <i>PFEER General Alarm</i>	0 1 1 1 0 1	Tone 46	Tone 37
Tone 48	420Hz @ 0.625s - <i>Australian Alert</i>	1 1 1 1 0 1	Tone 49	Tone 5
Tone 49	500-1200Hz 3.75s / 0.25s - <i>Australian Evacuate</i>	0 0 0 0 1 1	Tone 26	Tone 37

## Beacon Section Switch settings

Table 3.0

SW6 PS	SW5 OS	SW4 T4	SW3 T3	SW2 T2	SW1 T1	Timer	Periodic sound interval when silenced, when SW6 is ON for (1 second every)
		OFF	OFF	OFF	OFF	forever	10 secs
		OFF	OFF	OFF	ON	5 secs	5 secs
		OFF	OFF	ON	OFF	10 secs	5 secs
		OFF	OFF	ON	ON	20 secs	5 secs
		OFF	ON	OFF	OFF	30 secs	5 secs
		OFF	ON	OFF	ON	45 secs	10 secs
		OFF	ON	ON	OFF	1 min	10 secs
		OFF	ON	ON	ON	2 mins	10 secs
		ON	OFF	OFF	OFF	3 mins	30 secs
		ON	OFF	OFF	ON	5 mins	30 secs
		ON	OFF	ON	OFF	10 mins	1 min
		ON	OFF	ON	ON	20 mins	1 min
		ON	ON	OFF	OFF	30 mins	1 min
		ON	ON	OFF	ON	45 mins	5 mins
		ON	ON	ON	OFF	1 hour	5 mins
		ON	ON	ON	ON	2 hours	5 mins
	OFF					<b>Hold off mode</b> – Accept Switch silences sounder for selected time.	
	ON					<b>One-shot mode</b> — Sounder silences after either selected time, or Accept Switch is pressed, whichever occurs first. <b><i>The sounder is then only restored after the input power supply is removed and restored.</i></b>	
OFF						No periodic sound while silenced	
ON						Sound periodically while silenced	

Note: In order for these delay settings to function, power must be wired to the combined sounder beacon unit via the beacon section input terminals only.