

1) Introduction

The BExCS110-05D is a flameproof combined sounder / beacon which is certified to meet the requirements of the ATEX directive 94/9/EC and the IECEx scheme. The sounder section produces loud audio warning signals and the beacon section produces a synchronised visual warning signal. The unit can be used in hazardous areas where potentially flammable atmospheres may be present. Thirty-two different first stage audio alarm sounds can be selected by internal switches, and each one can be externally changed to a second or third stage alarm sound (see tone table on Page 5). The sounder produces output levels in the 110dB(A) range and the beacon has a flash energy of 5 joules. The unit can be used in Zone 1 and Zone 2 areas with gases in groups IIA and IIB and with Temperature Classifications of T1, T2, T3 and T4.

2) Marking

All units have a rating label, which carries the following important information:-

Unit Type No. BExCS110-05D

Input Voltage: DC Units 12V or 24V or 48V
AC Units 230V or 115V

Code: Ex d IIB T4 for Ta -50°C to +70°C

Certificate No. KEMA 01ATEX2223X
IECEx KEM 10.0025X

Epsilon x:
Equipment Group
And Category:

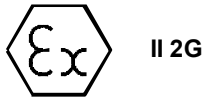

CE Marking:
Notified Body No.



“Warnings” DO NOT OPEN WHEN AN EXPLOSIVE
GAS ATMOSPHERE IS PRESENT

COVER BOLTS CLASS A4-80

USE HEAT RESISTING CABLES AND
CABLEGLANDS (Rated 110°C) AT
AMB. TEMPERATURES OVER 40°C

Year of Construction /
Serial No. i.e. 10 / 1CS21000001

3) Type Approval Standards

The units have an EC Type examination certificate issued by KEMA and have been approved to the following standards:-

EN60079-0:2006 IEC60079-0:2004 (Ed4) General Requirements
EN60079-1:2007 IEC60079-1:2007 (Ed6) Flameproof Enclosure 'd'

4) Installation Requirements

The unit must be installed in accordance with the latest issues of the relevant parts of the EN60079 specifications or the equivalent IEC specifications – Selection, Installation and maintenance of electrical apparatus for use in potentially explosive atmospheres (other than mining applications or explosive processing and manufacture):-

EN60079-14:2008 Electrical Installations in Hazardous
IEC60079-14:2007 (Ed4) Areas (other than mines)

EN60079-10:2003 Classification of Hazardous Areas
IEC60079-10:2008 (Ed1)

The installation of the unit must also be in accordance with any local codes that may apply and should only be carried out by a competent electrical engineer who has the necessary training.

5) Zones, Gas Group, Category and Temperature Classification

The BExCS110-05D unit has been certified Ex d IIB T4 for Ta -50°C to +70°C. This means that the units can be installed in locations with the following conditions:-

Area Classification:

Zone 1	Explosive gas air mixture likely to occur in normal operation.
Zone 2	Explosive gas air mixture not likely to occur, and if it does, it will only exist for a short time.

Gas Groupings:

Group IIA	Propane
Group IIB	Ethylene

Equipment Category: 2G

Temperature Classification:

T1	400°C
T2	300°C
T3	200°C
T4	135°C

Ambient Temperature Range:

-50°C to +70°C

6) Location and Mounting

The location of the unit should be made with due regard to the area over which both the sounder and beacon warning signal must be audible and visible. The unit should only be fixed to services that can carry the weight of the unit.

The unit should be securely bolted to a suitable surface using the 7mm diameter boltholes in the stainless steel U shaped mounting bracket (see figure 1). The angle can then be adjusted in the direction such that its warning signals can be both heard and seen. This can be achieved by loosening the two large bracket screws in the side of the unit, which allow adjustment in steps of 18°. On completion of the installation the two large bracket adjustment screws on the side of the unit must be fully tightened to ensure that the unit cannot move in service.

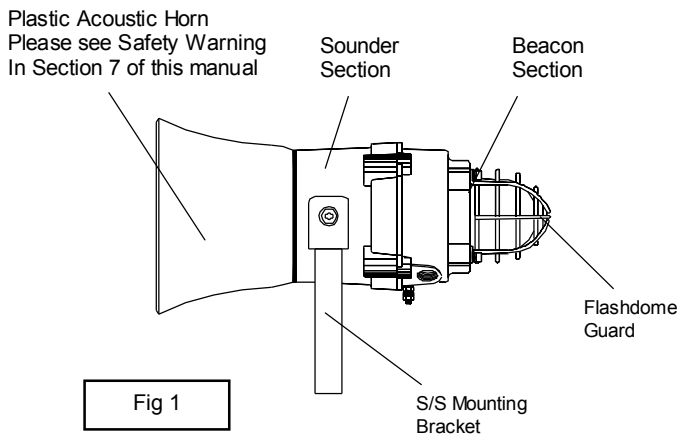

the air to be expelled. Only after the beacon section casting is fully in place should the four M6 Stainless Steel A4-80 cover bolts and their spring washer be inserted and tightened down. If the beacon section jams while it is being inserted, carefully remove it and try again. Never use the cover bolts to force the beacon section casting into position.

In case of repair, contact the manufacturer for information on the dimensions of the flameproof joints.

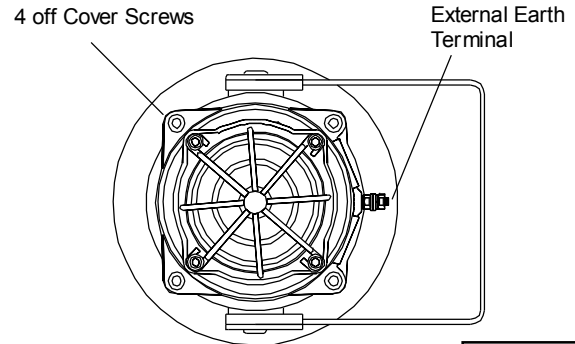

9) Power Supply Selection

It is important that a suitable power supply is used to run the unit. The power supply selected must have the necessary capacity to provide the input current to all of the units connected to the system. The sounder and beacon sections can both be wired to the same power supply or to different power supplies.

The following table shows the input current taken by the sounder section and beacon section of the various units:-

Unit Type	Input Voltage	Sounder Current	Max. I/P Volts
BExCS110-05D	24V DC	265mA	30V
BExCS110-05D	12V DC	195mA	15V
BExCS110-05D	48V DC	130mA	58V
BExCS110-05D	230V AC	56mA	264V
BExCS110-05D	115V AC	110mA	126V

Unit Type	Input Voltage	Beacon Current	Max. I/P Volts
BExCS110-05D	24V DC	300mA	30V
BExCS110-05D	12V DC	750mA	15V
BExCS110-05D	48V DC	180mA	58V
BExCS110-05D	230V AC	55mA	264V
BExCS110-05D	115V AC	140mA	126V

The above table also shows the maximum voltages at which the units can be operated.

Sounder Section

The input current to the sounder section will vary according to the voltage input level and the frequency of the tone selected. The current levels shown above are for the 440Hz Continuous tone @ nominal input voltage. The 24V and 48V DC units and the 230V AC, 115V AC units have a switching voltage regulator circuit and therefore the input current level will decrease slightly as the input voltage is increased and will increase slightly as the input voltage is reduced. The 12V

7) Safety Warning (Electrostatic Hazard)

The acoustic horn section is made of ABS Plastic, therefore to avoid a possible ELECTROSTATIC CHARGE the unit must only be cleaned with a damp cloth.

8) Access to the Flameproof Enclosure

In order to connect the electrical supply cables to the unit it is necessary to remove the beacon section to gain access to the flameproof chamber. To achieve this remove the four M6 hexagon socket head screws (see figure 2) and withdraw the beacon section taking extreme care not to damage the flameproof joints in the process.

Note the four **M6 screws are Class A4-80 stainless steel and only screws of this category can be used on these units.** It is therefore important that these screws and their spring washers are kept in a safe place during installation.

On completion of the cable wiring installation the flameproof joints should be inspected to ensure that they are clean and that they have not been damaged during installation. Also check that the earth bonding wire between the two casting sections is secure and the 'O' ring seal is in place. When replacing the beacon section casting, ensure that it is square with the sounder section chamber casting before inserting. Carefully push the beacon section in place allowing time for t

units do not have a voltage regulator and therefore their input current will increase when the input voltage is increased.

Beacon Section

The input current to the beacon section will vary according to the voltage input level. The current levels shown above are for nominal input voltage. The 12V, 24V and 48V DC units have a converter circuit and therefore the input current level will decrease slightly as the input voltage is increased and will increase slightly as the input voltage is reduced.

10) Cable Selection

When selecting the cable size consideration must be given to the input current that each unit draws (see table above), the number of units on the line and the length of the cable runs. The cable size selected must have the necessary capacity to provide the input current to all of the units connected to the line.

SAFETY WARNING: If the unit is used at high ambient temperatures, i.e. over +40°C, then the cable entry temperature may exceed +70°C and therefore suitable heat resisting cables must be used, with a rated service temperature of at least 110°C.

11) Earthing

Both AC and DC units must be connected to a good quality earth. The units are provided with internal and external earthing terminals, which are both, located on the beacon section of the unit (see figures 2 and 3).

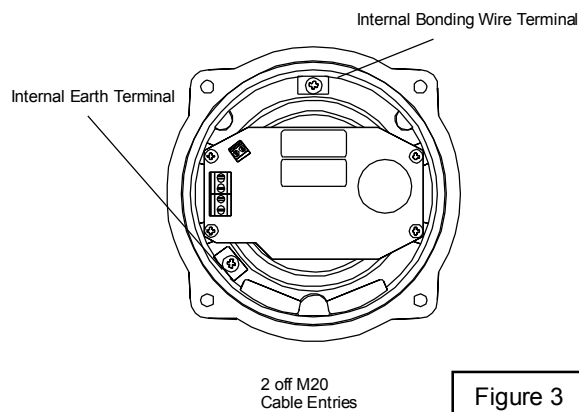

Figure 3

When using the internal earth terminal ensure that the stainless steel M4 flat washer is between the incoming earth wire and the enclosure.

When using the external earth terminal a cable crimp lug must be used. The cable lug should be located between the two M5 stainless steel flat washers. The M5 stainless steel spring washer must be fixed between the outer flat washer and the M5 stainless steel nut to ensure that the cable lug is secured against loosening and twisting.

The internal earth bonding wire ensures that a good quality earth is maintained between the sounder section casting and the beacon section casting.

12) Cable Glands

The BExCS110-05D unit has dual cable gland entries which have an M20 x1.5 entry thread as standard. Only cable glands approved for Ex 'd' applications can be used, which must be suitable for the type of cable being used and also meet the requirements of the Ex 'd' flameproof installation standard EN60079-14:2008 / IEC60079-14:2007.

SAFETY WARNING: If the unit is used at high ambient temperatures, i.e. over +40°C, then the cable entry temperature may exceed +70°C and therefore suitable heat resisting cable glands must be used, with a rated service temperature of at least 110°C.

If a high IP (Ingress Protection) rating is required then a suitable sealing washer must be fitted under the cable gland.

When only one cable entry is used the other one must be closed with an Ex 'd' flameproof blanking plug, which must be suitably approved for the installation requirements.

13) Cable Connections

The combined sounder beacon unit BExCS110-05D has separate printed circuit boards in the sounder and beacon sections. The terminals for the sounder are on the printed circuit board in the sounder section and the terminals for the beacon are on the printed circuit board in the beacon section (see figures 4&5 and 6&7). See section 8 of this manual for access to the enclosure and the wiring diagrams at the end of this manual.

The sounder and beacon sections can be wired to the same input supply so that they operate simultaneously or they can be wired to separate input supplies so they can be operated independently (see diagrams of pages 5 and 6 of this manual). If the sounder and beacon sections are connected to the same input supply, the incoming cables should be connected to the input terminals on the beacon board and the two connecting wires, that are supplied with the unit, should be used to link the supply from the interconnecting terminals on the beacon board down to the supply terminals on the sounder board.

SOUNDER SECTION CONNECTIONS

On the AC units a two-way terminal block is provided for the live and neutral mains supply wires and a three way terminal block is provided for linking the second and third stages, (see figure 7). On the DC units a four way terminal block is provided for +ve and -ve supply input and second and third stage modes of operation, (see figure 6).

A single wire with a cross sectional area of up to 4mm² can be connected to each terminal way or if an input and output wire is required two 2.5mm² wires can be connected to each terminal way. When connecting wires to the terminals great care should be taken to dress the wire so that when the beacon section is inserted into the chamber the wires do not exert excess pressure on the terminal blocks. This is particularly important when using cables with large cross sectional areas such as 2.5mm² and above. If the sounder is wired to the same power supply as the beacon always use the flexible interconnecting wires provided.

BEACON SECTION CONNECTIONS

The cable connections are made into the terminal blocks on the electronic pcb assembly located in the beacon section enclosure. A four-way terminal block is provided on both AC and DC beacons. Therefore there are two live terminals and

two neutral terminals for the input and output wiring on AC units. On the DC units there are two +ve terminals and two -ve terminals for the input and output wiring.

Wires having a cross sectional area of up to 4mm² can be connected to each terminal way. When connecting wires to the terminals great care should be taken to dress the wires so that wires do not exert excess pressure on the terminal blocks. This is particularly important when using cables with large cross sectional areas such as 2.5mm² and above.

BExCS110-05D AC Beacon Section

Interconnecting Terminals to sounder pcb (simultaneous mode of operation)

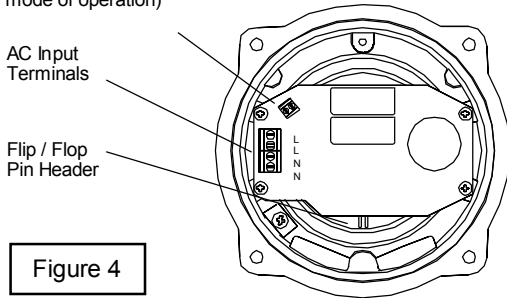

Figure 4

BExCS110-05D DC Beacon Section

Interconnecting Terminals to sounder pcb (simultaneous mode of operation)

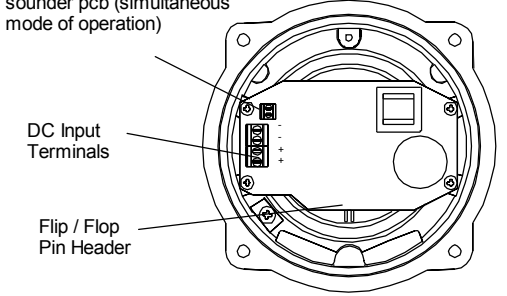

Figure 5

14) Tone Selection and 2nd and 3rd Stage Alarms

The BExCS110-05D sounder section has 32 different tones that can be selected for the first stage alarm. The sounders can then be switched to sound second and third stage alarm tones. The tones are selected by operation of a DIP switch on the sounder pcb for both DC and AC units. The tone table on page five shows the switch positions for the 32 tones and which tones are available for the second and third stages. To operate the sounder on stage one simply connect the supply voltage to the normal supply terminals (+ve and -ve for DC units, L and N for AC units).

The operation of the second and third stages is different for DC and AC units.

DC Units Second and Third Stage Tone Selection

The BExCS110-05D DC sounder section has the facility to use either +ve or -ve switching to change the tone to the second and third stages. For -ve switching connect the two headers on the pcb to the left-hand (marked -ve) and centre pins. For +ve switching connect the headers to the right hand (marked +ve) and the centre pins. To change to the second stage tone, connect either a -ve or +ve supply line to terminal S2, depending on which switching mode is being used while maintaining the dc supply to the +ve and -ve terminals. Similarly for the third stage tone, connect a -ve or +ve supply line to terminal S3. The supply to the S3 terminal will automatically override a supply to the S2 terminal.

AC Units Second and Third Stage Tone Selection

To select the second and third stage tones on the BExCS110-05D AC sounder section, the Common (C) terminal on the three way terminal block on the pcb is connected to the S2 terminal for the second stage tone and the S3 terminal for the third stage tone.

BExCS110-05D DC Sounder Section

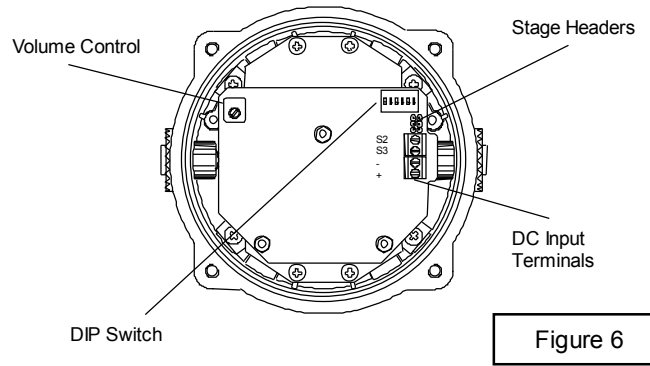

Figure 6

BExCS110-05D AC Sounder Section

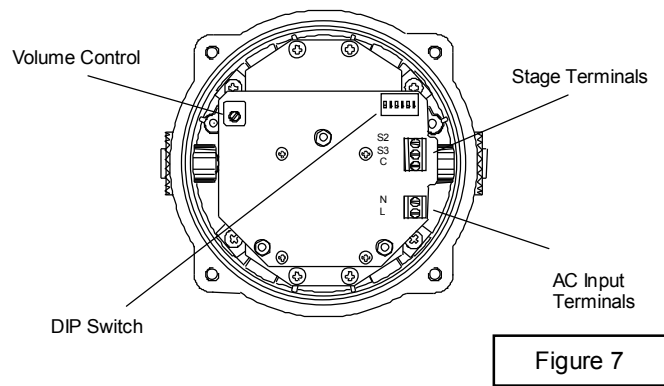

Figure 7

15) Volume Control

The BExCS110-05D sounder section, with the exception of 12V DC units, has a volume control to adjust the output level. To set the required output level, adjust the potentiometer on the pcb. For maximum output level the potentiometer should be set to the fully clockwise position.

16) End of Line Monitoring (DC Units)

On BExCS110-05D DC units, dc reverse line monitoring can be used if required. All DC units have a blocking diode fitted in their supply input lines on both the sounder section and the beacon section. An end of line monitoring diode or an end of line monitoring resistor can be connected across the +ve and -ve terminals. If an end of line resistor is used it must have a minimum resistance value of 3k3 ohms and a minimum wattage of 0.5 watts or a minimum resistance value of 500 ohms and a min. wattage of 2 watts. If the sounder and beacon sections are wired to separate power supplies then an end of line monitoring component can be used in each section.

17) Synchronised Operation

All BExCS110-05D units that are connected to the same supply line will have a synchronized sound output and a synchronised flash rate at one flash every second. To ensure that the units will be synchronised check that the pin header is not fitted, i.e. the two header pins are not shorted together (see Figures 4 and 5).

18) Flip / Flop Operation

Two units can be mounted close to each other to form a flip-flop operation, where the beacons will flash alternately. To achieve this mode of operation, fit a pin header to the flip-flop header pins on the electronics board, i.e. the two header pins are shorted together, (see figures 4 and 5) on one of the two beacons. The first flash on the beacon that has the header fitted will be delayed by 1/2 second. The two beacons will then flash alternately every 1/2 a second.

TONE SELECTION TABLE

Tone Selection		DIP Switch Settings					Stage Selection	
Stage 1	Frequency Description	1	2	3	4	5	Stage 2	Stage 3
1	Continuous 1000Hz <i>Toxic gas alarm</i>	0	0	0	0	0	Tone 31	Tone 11
2	Alternating 800/1000Hz at 0.25s intervals	1	0	0	0	0	Tone 17	Tone 5
3	Slow Whoop 500/1200Hz at 0.3Hz with 0.5s gap repeated	0	1	0	0	0	Tone 2	Tone 5
4	Sweeping 800/1000 at 1Hz	1	1	0	0	0	Tone 6	Tone 5
5	Continuous at 2400Hz	0	0	1	0	0	Tone 3	Tone 27
6	Sweeping 2400/2900Hz at 7Hz	1	0	1	0	0	Tone 7	Tone 5
7	Sweeping 2400/2900Hz at 1Hz	0	1	1	0	0	Tone 10	Tone 5
8	Siren 500/1200/500Hz at 0.3Hz	1	1	1	0	0	Tone 2	Tone 5
9	Sawtooth 1200/500Hz at 1Hz	0	0	0	1	0	Tone 15	Tone 2
10	Alternating 2400/2900Hz at 2Hz	1	0	0	1	0	Tone 7	Tone 5
11	Intermittent 1000Hz at 0.5Hz <i>General alarm</i>	0	1	0	1	0	Tone 31	Tone 1
12	Alternating 800/1000Hz at 0.875Hz	1	1	0	1	0	Tone 4	Tone 5
13	Intermittent 2400Hz at 1Hz	0	0	1	1	0	Tone 15	Tone 5
14	Intermittent 800Hz 0.25s on 1s off	1	0	1	1	0	Tone 4	Tone 5
15	Continuous at 800Hz	0	1	1	1	0	Tone 2	Tone 5
16	Intermittent 660Hz 150mS on, 150mS off	1	1	1	1	0	Tone 18	Tone 5
17	Alternating 544Hz (100mS)/440Hz(400mS)	0	0	0	0	1	Tone 2	Tone 27
18	Intermittent 660Hz 1.8s on, 1.8s off	1	0	0	0	1	Tone 2	Tone 5
19	1400Hz to 1600Hz sweep up over 1s - 1600Hz to 1400Hz sweep down over 0.5s	0	1	0	0	1	Tone 2	Tone 5
20	Continuous 660Hz	1	1	0	0	1	Tone 2	Tone 5
21	Alternating 554/440Hz at 1Hz	0	0	1	0	1	Tone 2	Tone 5
22	Intermittent 554Hz at 0.875Hz	1	0	1	0	1	Tone 2	Tone 5
23	800Hz pulsing at 2Hz	0	1	1	0	1	Tone 6	Tone 5
24	Sweeping 800/1000Hz at 50Hz	1	1	1	0	1	Tone 29	Tone 5
25	Sweeping 2400/2900Hz at 50Hz	0	0	0	1	1	Tone 29	Tone 5
26	Simulated bell sound	1	0	0	1	1	Tone 2	Tone 1
27	Continuous 554Hz	0	1	0	1	1	Tone 26	Tone 5
28	Continuous 440Hz	1	1	0	1	1	Tone 2	Tone 5
29	Sweeping 800/1000Hz at 7Hz	0	0	1	1	1	Tone 7	Tone 5
30	420Hz repeating 0.625s on, 0.625s off <i>Australian alert signal</i>	1	0	1	1	1	Tone 32	Tone 5
31	1200/500Hz at 1 Hz <i>Prepare to abandon platform</i>	0	1	1	1	1	Tone 11	Tone 1
32	Sweeping 500/1200Hz 3.75s on, 0.25s off 15Hz	1	1	1	1	1	Tone 26	Tone 1

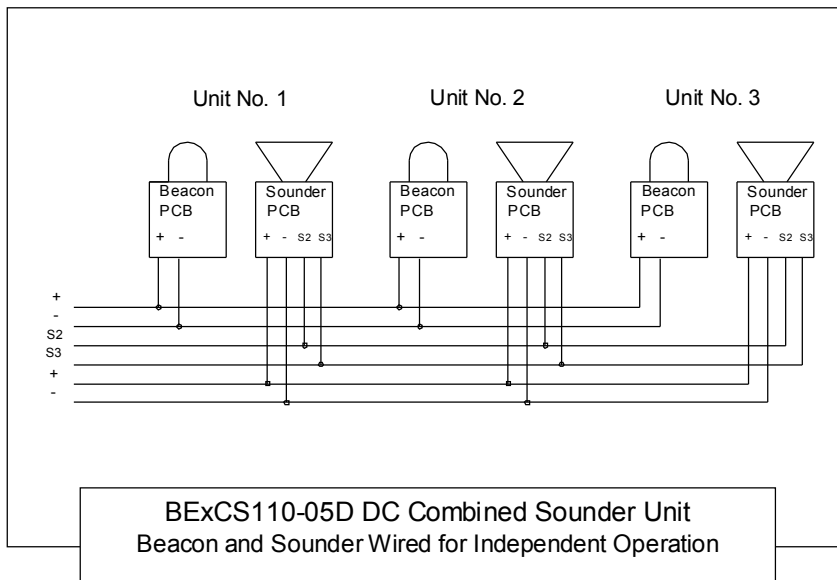

NOTE

Either the +ve or the -ve wire may be made common to both the sounder and the beacon to reduce the number of cores in the cable.

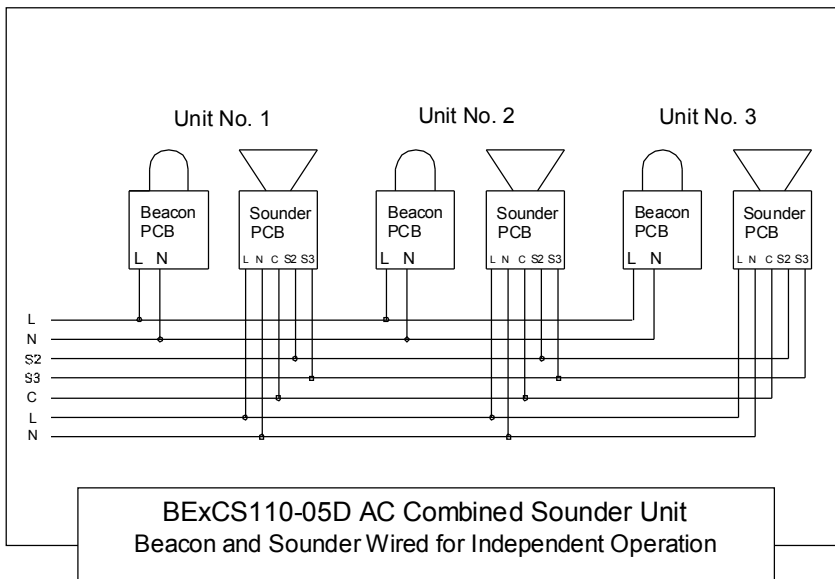
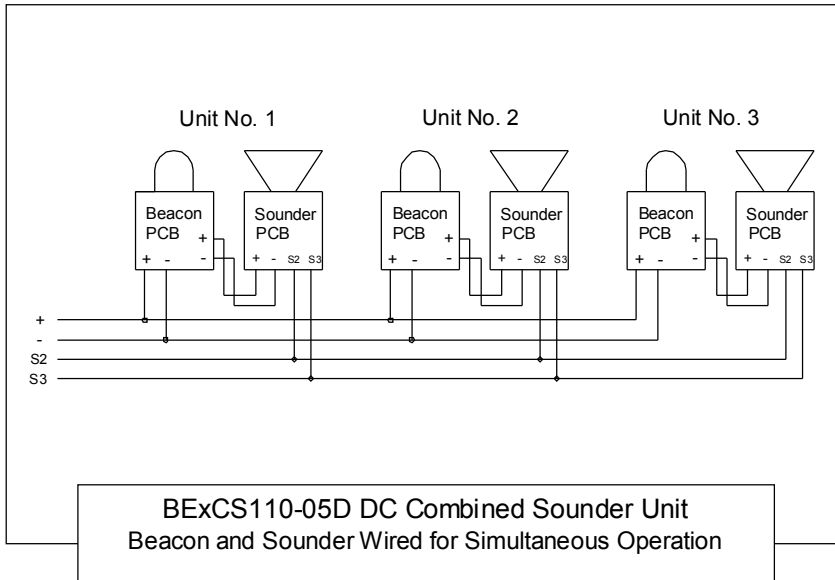

NOTE
Either the L or the N wire may be made common to both the sounder and the beacon to reduce the number of cores in the cable.

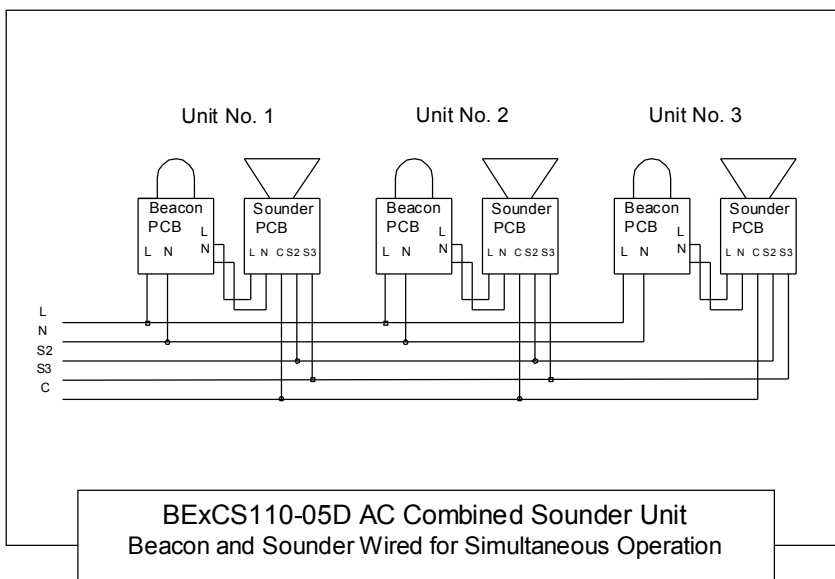

EC DECLARATION OF CONFORMITY



Manufacturer: European Safety Systems Ltd.
Impress House, Mansell Road, Acton
London, W3 7QH, UK

Equipment Type: BExCS110-05D, BExDCS110-05D,
BExCL15-05D, BExDCL15-05D,
BExCA110-05D, BExDCA110-05D,
BExCTS110-05D, BExDCTS110-05D,
BExCTV110-05D, BExDCTV110-05D
BExCS110L1D, BExDCS110L1D

Directive 94/9/EC: Electrical and Mechanical equipment for use in explosive atmospheres (ATEX)

Notified Body for EC type Examination: KEMA Quality B.V.
Notified Body No.: 0344
Utrechtseweg 310, 6812 AR Arnhem, The Netherlands

EC-type Examination Certificate: KEMA 01ATEX2223X

Notified Body for Quality Assurance Notification: Sira Certification Service
Notified Body No.: 0518
Rake Lane, Eccleston, Chester CH4 9JN, UK

Quality Assurance Notification: SIRA 05 ATEX M342

Provisions fulfilled by the equipment: II 2 G Ex d IIB T4
II 2 D Ex tD A21 IPGX T100 °C or T115 °C

Standards applied: EN 60079-0:2006
EN 60079-1:2007
EN 61241-0:2006
EN61241-1:2004

Directive 2004/108/EC: Electromagnetic Compatibility Directive (EMC)

Standards applied: EN 61000-6-1:2007
EN 61000-6-2:2005
EN 61000-6-3:2007
EN 61000-6-4:2007

The standards EN 60079-0: 2006, EN 61241-0:2006 and EN 61241-1:2004 are no longer harmonized. The requirements of these standards have been checked against the harmonized standards EN 60079-0:2009 and EN 60079-31:2009 and there were no major technical changes affecting the latest technical knowledge for the products listed above.

On behalf of European Safety Systems Ltd., I declare that, on the date the equipment accompanied by this declaration is placed on the market, the equipment conforms with all technical and regulatory requirements of the above listed directives.

A handwritten signature in black ink, appearing to read 'Martin Streetz', written over a light blue circular stamp.

Martin Streetz
Quality Assurance Manager

Date and Place of Issue: London, 04/07/2012
Document No: DC-005-Issue_C