

BExCBGL2-05D

### 1) Warnings



- DO NOT OPEN WHEN AN EXPLOSIVE ATMOSPHERE IS PRESENT
- DO NOT OPEN WHEN ENERGIZED
- POTENTIAL ELECTROSTATIC CHARGING HAZARD
- COVER BOLTS CLASS A4-80
- USE HEAT RESISTING CABLES AND CABLE GLANDS (RATED 110°C) AT AMB. TEMPERATURES OVER 40°C

### 2) Rating & Marking Information

All units have a rating label, which carries the following important information:-

**Model No.:** BExCBGL2-05D

**Input Voltage:** DC Units 24V or 48V  
 AC Units 115V or 230V

**BExCBGL2-05D -P Codes:**

- Ex d IIB T5 Gb Ta. -50°C to +40°C
- Ex d IIB T4 Gb Ta. -50°C to +70°C
- Ex tb IIIC T95°C Db Ta. -50°C to +40°C
- Ex tb IIIC T110°C Db Ta. -50°C to +55°C
- Ex tb IIIC T125°C Db Ta. -50°C to +70°C

**Certificate No.** KEMA 01ATEX2222X  
 IECEx KEM 10.0024X

Epsilon x  
 Equipment Group and  
 Category:

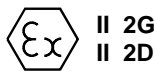

CE Marking  
 Notified Body No.

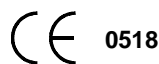

The units can be installed in locations with the following conditions:

**Area Classification Gas:**

Zone 1	Explosive gas air mixture likely to occur in normal operation.
Zone 2	Explosive gas atmosphere not likely to occur in normal operation but may be present for short periods.

**Gas Groupings:**

Group IIA	Propane
Group IIB	Ethylene
Group IIC	Hydrogen and Acetylene

**Temperature Classification:**

T1	450°C
T2	300°C
T3	200°C
T4	135°C
T5	100°C (up to 40°C ambient)

**Area Classification Dust:**

Zone 21	Explosive dust air mixture likely to occur in normal operation.
Zone 22	Explosive dust air mixture not likely to occur in normal operation, and if it does, it will only exist for a short time.

**Dust Groupings:**

Group IIIA	Combustible Dusts
Group IIIB	Non-Conductive Dust
Group IIIC	Conductive Dust

**Maximum Surface Temperature for Dust Applications:**

- 95°C at +40°C ambient
- 110°C at +55°C ambient
- 125°C at +70°C ambient

**IP Rating:** IP66/67 to EN/IEC60529 and IP6X to EN/IEC60079-0, EN/IEC60079-31

**Equipment Category:** 2G / 2D

**Equipment Protection Level:** Gb / Db

**Ambient Temperature Range:**

- 50°C to +70°C Gas Groups IIA, IIB and IIC
- 50°C to +70°C Dust Groups IIIA, IIIB and IIIC

### 3) Type Approval Standards

The combined beacon / beacon carries an EC Type Examination Certificate and IECEx Certificate of Conformity, and have been certified to comply with the following standards:

EN60079-0:2012+A11:2013 / IEC60079-0:2011 (Ed 6):  
Explosive Atmospheres - Equipment. General requirements

EN60079-1:2007 / IEC60079-1:2007 (Ed 6):  
Explosive Atmospheres - Equipment protection by flameproof enclosures "d"

EN 60079-31:2014 / IEC60079-31:2013 (Ed 2):  
Explosive Atmospheres - Equipment dust ignition protection by enclosure "t"

### 4) Installation Requirements

The combined beacon / beacon must only be installed by suitably qualified personnel in accordance with the latest issues of the relevant standards:

EN60079-14 / IEC60079-14: Explosive atmospheres -  
Electrical installations design, selection and erection

EN60079-10-1 / IEC60079-10-1: Explosive atmospheres -  
Classification of areas. Explosive gas atmospheres

EN60079-10-2 / IEC60079-10-2: Explosive atmospheres -  
Classification of areas. Explosive dust atmospheres

The installation of the combined beacon / beacon must also be in accordance with any local codes that may apply and should only be carried out by a competent electrical engineer who has the necessary training.

### 5) Special Conditions of Use

Repair of the flamepath / flameproof joints is not permitted.

The enclosure is non-conducting and may generate an ignition-capable level of electrostatic charges under certain extreme conditions (such as high-pressure steam). The user should ensure that the equipment is not installed in a location where it may be subjected to external conditions that might cause a build-up of electrostatic charges on non-conducting surfaces.

Additionally, cleaning of the equipment should be done only with a damp cloth.

### 6) Location and Mounting

The location of the combined beacon / beacon should be made with due regard to the area over which the warning signal must be visible. They should only be fixed to services that can carry the weight of the unit.

The BEx combined beacon / beacon should be secured to any flat surface using the three 7mm fixing holes on the stainless steel U shaped mounting bracket. See Figure 1. The required angle can be achieved by loosening the two large bracket screws in the side of the unit, which allow adjustment of the combined beacon / beacon in steps of 18°. On completion of the installation then two large bracket adjustment screws on the side of the unit must be fully tightened to ensure that the unit cannot move in service.

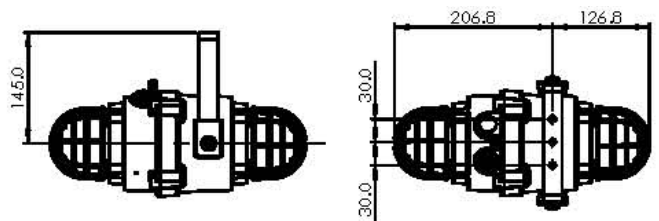

Fig. 1 Fixing Location for Combined Beacon/Beacon

### 7) Access to the Flameproof Enclosure



Warning – High voltage may be present, risk of electric shock. DO NOT open when energised, disconnect power before opening.



Warning – Hot surfaces. External surfaces and internal components may be hot after operation, take care when handling the equipment.

To access the Ex d chamber, remove the four M6 hexagon socket head screws and withdraw the flameproof cover taking extreme care not to damage the flameproof joints in the process. M6 cover screws are Class A4-80 stainless steel and only screws of this category can be used for the enclosure.

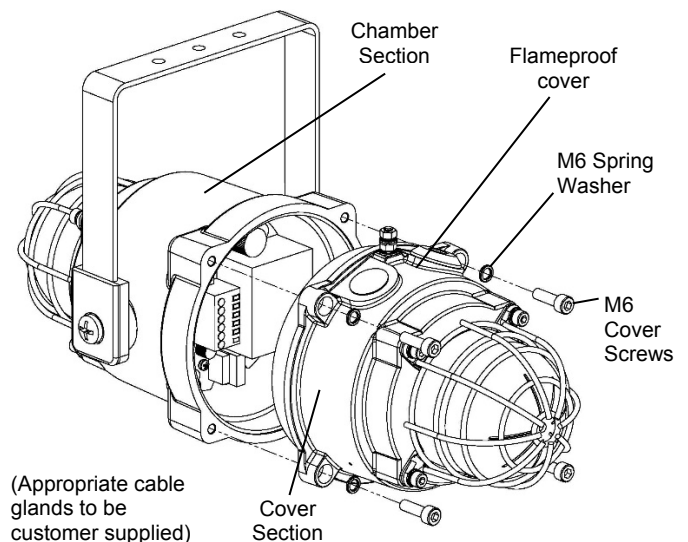

Fig. 2 Accessing the Explosion proof Enclosure.

On completion of the installation, the flameproof joints should be inspected to ensure that they are clean and that they have not been damaged during installation.

Check that the earth bonding wire between the two castings is secure and the 'O' ring seal is in place. When replacing the flameproof cover casting ensure that it is square with the flameproof chamber casting before inserting. Carefully push the cover in place allowing time for the air to be expelled. Only after the cover is fully in place should the four M6 Stainless Steel A4-80 cover bolts and their spring washer be inserted and tightened down. If the cover jams while it is being inserted, carefully remove it and try again. Never use the cover bolts to force the cover into position.

## 8) Power Supply Selection

It is important that a suitable power supply is used to run the equipment. The power supply selected must have the necessary capacity to provide the input current to all of the units.

The following table shows the input current taken by the various combined beacon / beacons and shows the maximum voltage at which the combined sounder beacons can be operated:

Model No.	Nominal I/P Voltage	Chamber Beacon Current	Cover Beacon Current	Max. I/P Volts
BExCBGL2-05D DC024	24Vdc	240mA	300mA	28V
BExCBGL2-05D DC048	48Vdc	130mA	180mA	54V
BExCBGL2-05D AC115	115Vac	85mA	140mA	126V
BExCBGL2-05D AC230	230Vac	48mA	55mA	253V

The input current to the beacon section will vary according to the voltage input level. The current levels shown above are for nominal input voltage.

## 9) Selection of Cable, Cable Glands, Blanking Elements & Adapters

When selecting the cable size, consideration must be given to the input current that each unit draws (see table above), the number of combined sounder beacons on the line and the length of the cable runs. The cable size selected must have the necessary capacity to provide the input current to all of the combined sounder beacons connected to the line.

For ambient temperatures over +40°C the cable entry temperature may exceed +70°C and therefore suitable heat resisting cables and cable glands must be used, with a rated service temperature of at least 110°C

The dual cable gland entries have an M20 x 1.5 entry thread. To maintain the ingress protection rating and mode of protection, the cable entries must be fitted with suitably rated ATEX / IECEx certified cable glands and/or suitably rated ATEX / IECEx certified blanking devices during installation according to EN / IEC60079-14.

If a high IP (Ingress Protection) rating is required then a suitable sealing washer must be fitted under the cable glands or blanking plugs.

For use in explosive dust atmospheres, a minimum ingress protection rating of IP6X must be maintained.

The BEx combined beacon / beacon range can be supplied with the following types of adapters:

M20 to ½" NPT  
M20 to ¾" NPT  
M20 to M25

It is important to note that stopping plugs cannot be fitted onto adapters, only directly onto the M20 entries.

Any other adapters used must be suitably rated and ATEX / IECEx certified adapters.

## 10) Earthing

Both AC and DC combined beacon / beacon units must be connected to an earth. The units are provided with internal and external earth terminals which are both located on the terminal chamber section of the unit.

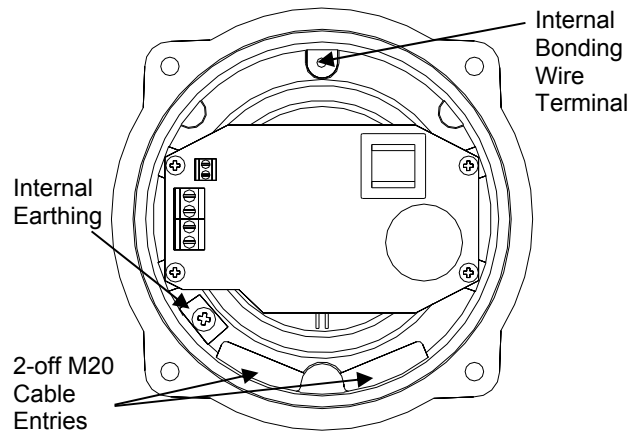

Fig. 3 Internal View of Cover

When using the internal earth terminal ensure that the stainless steel M4 flat washer is between the incoming earth wire and the enclosure.

Internal earthing connections should be made to the Internal Earth terminal in the cover casting using a ring crimp terminal to secure the earth conductor under the earth clamp. The earth conductor should be at least equal in size and rating to the incoming power conductors.

External earthing connections should be made to the M5 earth stud, using a ring crimp terminal to secure the earth conductor to the earth stud. The external earth conductor should be at least 4mm<sup>2</sup> in size.

## 11) Cable Connections

The combined beacon / beacon unit BExCBGL2-05D has separate printed circuit boards in the chamber and cover sections. The terminals for the sounder are on the printed circuit board in the sounder section and the terminals for the beacon are on the printed circuit board in the beacon section (see figures 4a, 4b, 6a and 6b). See section 7 of this manual for access to the enclosure. See section 12 and 13 for AC and DC wiring diagrams respectively.

Wires having a cross sectional area between 0.5 mm<sup>2</sup> to 2.5mm<sup>2</sup> can be connected to each terminal way. If an input and output wire is required the 2-off Live/Neutral or +/- terminals can be used. If fitting 2-off wires to one terminal way the sum of the 2-off wires must be a maximum cross sectional area of 2.5mm<sup>2</sup>. Strip wires to 8mm. Wires may also be fitted using ferrules. Terminal screws need to be tightened down with a tightening torque of 0.45 Nm / 5 Lb-in. When connecting wires to the terminals great care should be taken to dress the wires so that when the cover is inserted into the chamber the wires do not exert excess pressure on the terminal blocks. This is particularly important when using cables with large cross sectional areas such as 2.5mm<sup>2</sup>.

## 12) AC Wiring

A 6-way terminal block is provided on the AC chamber beacon for power. There are 2-off Live, 2-off Neutral and 2-off Earth terminals in total. A 4-way terminal block is provided on the AC cover beacon for power. There are 2-off Live and 2-off Neutral terminals in total.

### 12.1 Wiring Diagrams

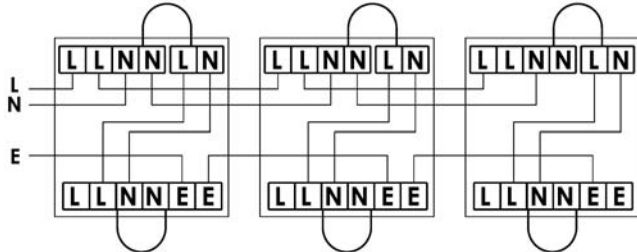

Fig 4a. BExCBGL2-05DAC Simplified Block Diagram for simultaneous operation

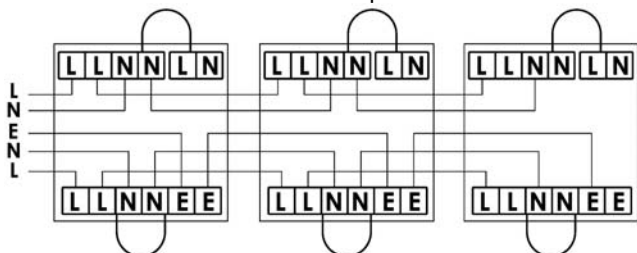

Fig 4b. BExCBGL2-05D AC Simplified Block Diagram for independent operation

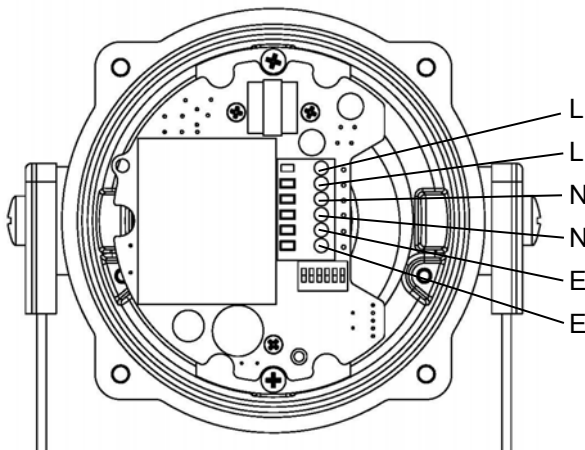

Fig. 5a Chamber LED Beacon AC Terminals

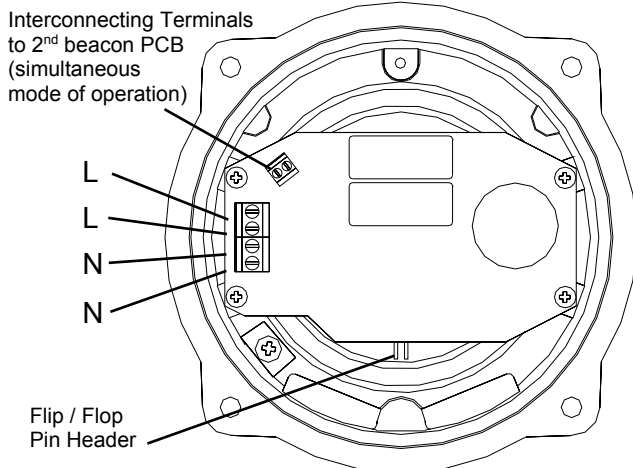

Fig. 5b Cover Xenon Beacon AC Terminals

## 13) DC Wiring

A 6-way terminal block is provided on the DC chamber beacon for power. There are 2-off +ve, 2-off -ve, 1-off stage 2 and 1-off stage 3 terminals in total. A 4-way terminal block is provided on the DC cover beacon for power. There are 2-off +ve and 2-off -ve terminals in total.

### 13.1 Wiring Diagrams

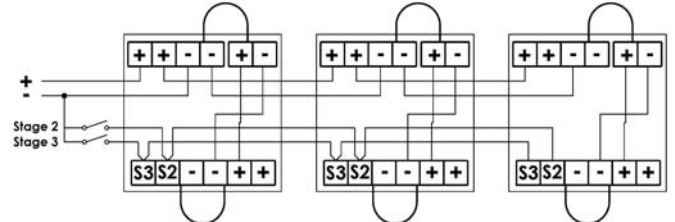

Fig 6a. BExCBGL2-05D AC Simplified Block Diagram for simultaneous operation (negative switching)

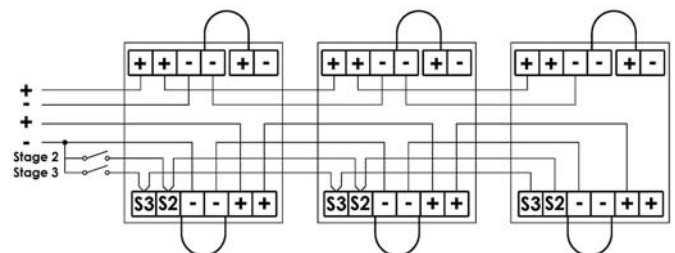

Fig 6b. BExCBGL2-05D AC Simplified Block Diagram for independent operation (negative switching)

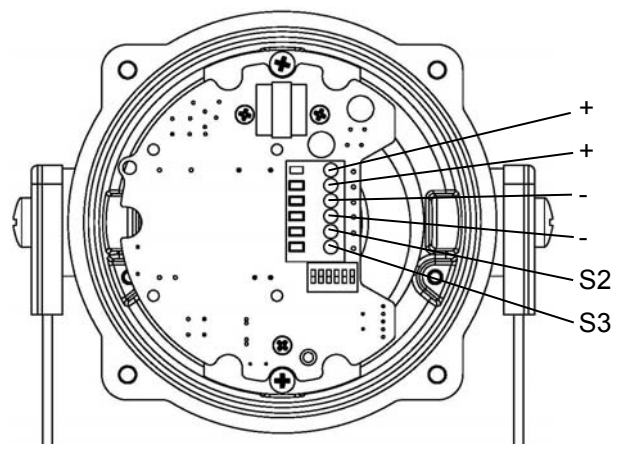

Fig. 7a Chamber LED Beacon DC Terminals

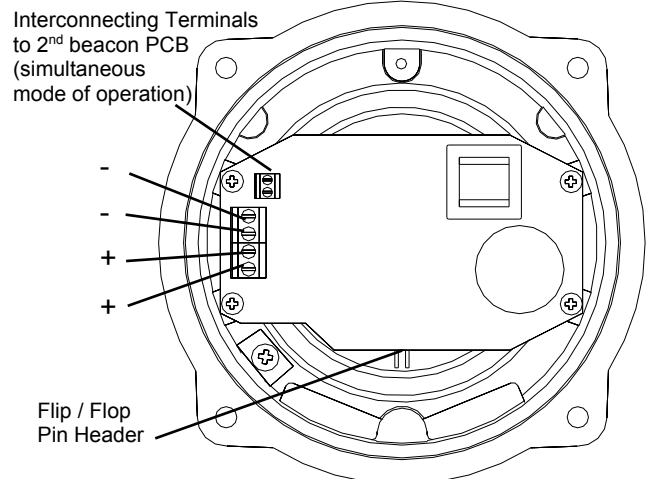

Fig. 7b Cover Xenon Beacon DC Terminals

## 13.2 Line Monitoring

On BExCBGL2-05D DC units, dc reverse line monitoring can be used if required. All DC sounders have a blocking diode fitted in their supply input lines. An end of line monitoring diode or an end of line monitoring resistor can be connected across the +ve and -ve terminals. If an end of line resistor is used it must have a minimum resistance value of 3k3Ω and a minimum power rating of 0.5 watts or a minimum resistance value of 500Ω and a minimum power rating of 2 watts.

The resistor must be connected directly across the +ve and -ve terminals as shown in the following drawing. The resistor leads should be kept as short as possible.

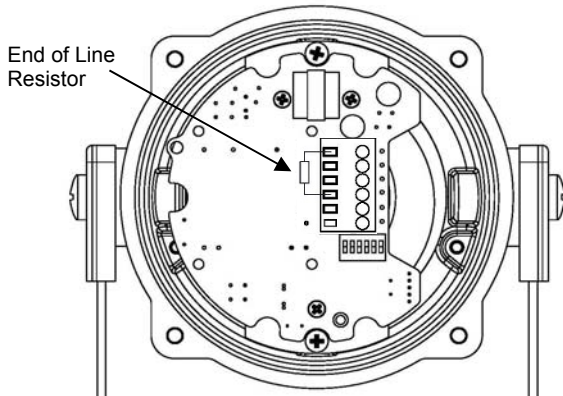

Fig. 8 End of Line Resistor Placement

## 14) Wiring the combined sounder/beacon for simultaneous operation

Both beacon sections can be wired to the same input supply so that they operate simultaneously (see fig. 4a & 6a) or they can be wired to separate input supplies so they can be operated independently (see fig. 4b & 6b).

If the chamber and cover sections are connected to the same input supply. The incoming cables should be connected to the input terminals on the cover section beacon board and the two link wires, that are supplied with the unit, should be used to link the supply from the interconnecting terminals on the cover section beacon board down to the supply terminals on the chamber section beacon board.

## 15) Settings

### 15.1 Flash Rate Settings



Warning – high-intensity light source. Avoid looking directly at the light source for extended periods of time.

The BExB2L2D beacons can produce different flash patterns as shown in Table 1. The flash patterns are selected by operation of the flash setting DIP switch on the PCB, Fig 6.

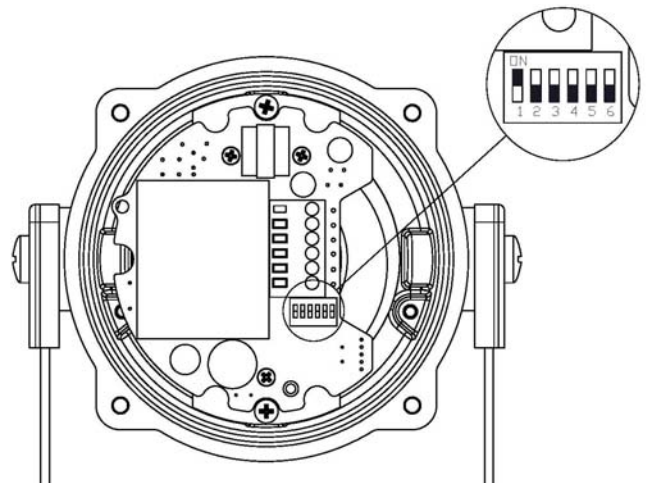

Fig. 9: DIP Switch Location

Switch Setting	S1 Mode	S2 Mode	S3 Mode
(123456)	(DC & AC)	(DC Only)	(DC Only)
000000	Steady High Power	Flashing 1Hz	Flashing Triple Strike
000001	Steady Low Power	Flashing 1Hz	Flashing Triple Strike
100000	Flashing 1Hz	Flashing Double Strike	Flashing Triple Strike
101000	Flashing 1.5Hz	Flashing 2Hz	Flashing Double Strike
010000	Flashing 2Hz	Flashing Triple Strike	Flashing Triple Strike
110000	Flashing Double Strike	Steady High Power	Flashing Triple Strike
001000	Flashing Triple Strike	Flashing 2Hz	Flashing Double Strike

Table 1: Switch Positions for Flash Patterns

## 15.2 Flip/Flop Operation

Two units can be mounted close to each other to form a flip-flop operation, where the cover beacons will flash alternately. To achieve this mode of operation, fit a pin header to the flip-flop header pins on the electronics board, i.e. the two header pins are shorted together, on one of the two beacons. The first flash on the beacon that has the header fitted will be delayed by ½ second. The two beacons will then flash alternately every ½ a second.

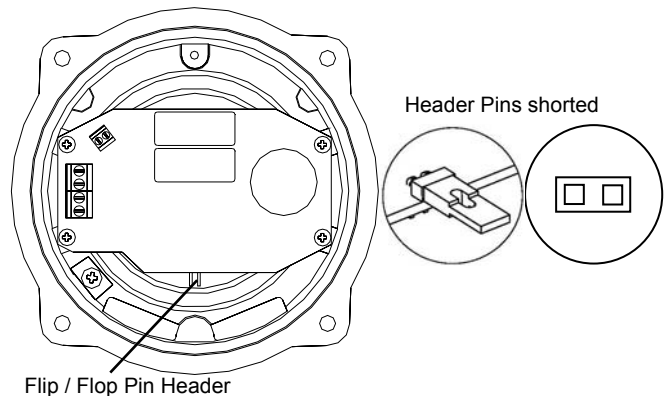

Fig. 10 Header Pin Settings

## 16) Interchangeable & Spare Parts



Warning – Hot surfaces. External surfaces and internal components may be hot after operation, take care when handling the equipment.

The beacon cover is interchangeable, contact E2S Ltd for a replacement cover available in various colours.

To change the cover, unscrew the M5 socket head screws and remove the M5 screws, M5 spring & flat washers.

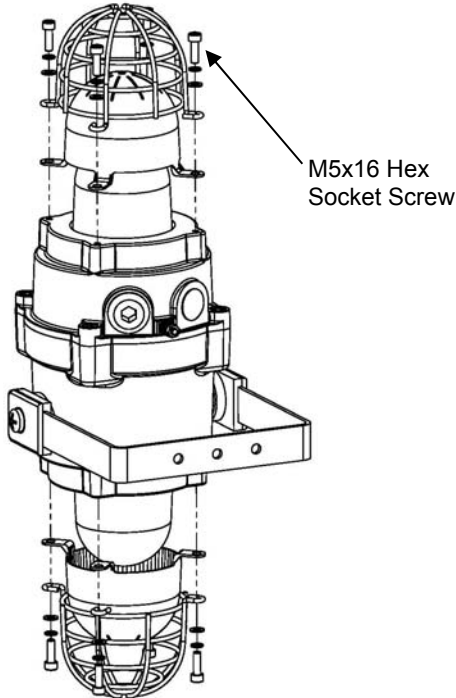

Fig. 11 Removal of cover

Remove the guard and replace the old cover with the new cover.

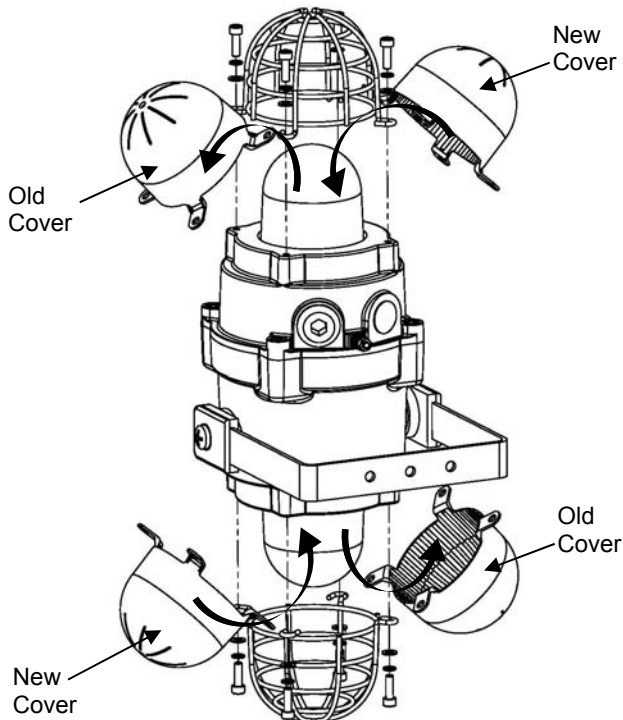

Fig. 12 Changing of cover

Fit the guard back on to the cover and casting, align the holes of the guard, cover and casting. To reattach the cover, the fixings MUST be in the order shown in figure 12.

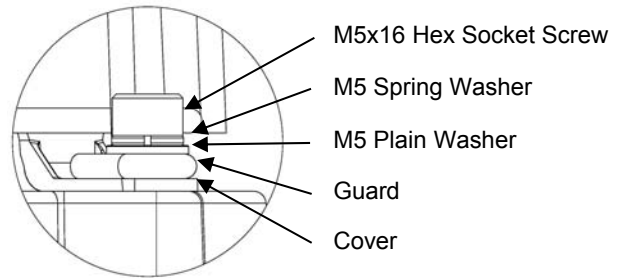

Fig. 13 Cover and Guard Fixtures

## 17) Maintenance, Overhaul & Repair

Maintenance, repair and overhaul of the equipment should only be carried out by suitably qualified personnel in accordance with the current relevant standards:

EN60079-19	Explosive atmospheres - Equipment repair, overhaul and reclamation
IEC60079-19	
EN 60079-17	Explosive atmospheres - Electrical installations inspection and maintenance
IEC60079-17	

To avoid a possible ELECTROSTATIC CHARGE the unit must only be cleaned with a damp cloth.

Units must not be opened while an explosive atmosphere is present.

If opening the unit during maintenance operations a clean environment must be maintained and any dust layer removed prior to opening the unit. Flameproof threaded joints and cemented joints are not intended to be repaired.