



# INSTRUCTION MANUAL (ATEX / IECEx)

## BExCBG05-05D

### Flameproof Combined Beacon / Beacon

#### For use in Flammable Gas and Dust Atmospheres

### 1) Introduction

The BExCBG05-05D is a flameproof combined beacon / beacon which is certified to meet the requirements of the ATEX directive 94/9/EC and the IECEx scheme. Each beacon section produces a synchronised visual warning signal and has a flash energy of 5 joules. The unit can be used in hazardous areas where potentially flammable gas and dust atmospheres may be present. The unit can be used in Zone 1 and Zone 2 areas with gases in groups IIA and IIB and with Temperature Classifications of T1, T2, T3, T4 and T5 and can also be used in Zone 21 and Zone 22 areas for combustible dusts and have an IP rating of IP 67 and a surface temperature rating of T115°C (T100°C at +55°C).

### 2) Marking

All units have a rating label, which carries the following important information:-

Unit Type No. BExCBG050-05D

Input Voltage: DC Units 12V or 24V or 48V  
AC Units 230V or 115V

Codes:

Ex d IIB T4 for Ta -50°C to +70°C  
Ex d IIB T5 for Ta -50°C to +55°C  
Ex tD A21 IP6X T115°C based on max Ta of +70°C

Certificate No. KEMA 01ATEX2222X  
IECEx KEM 10.0024X

Epsilon x:  
Equipment Group and  
Category:

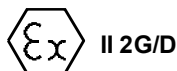

CE Marking:  
Notified Body No.

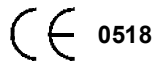

**“Warnings”** DO NOT OPEN WHEN AN EXPLOSIVE  
GAS / DUST ATMOSPHERE IS PRESENT

COVER BOLTS CLASS A4-80

USE HEAT RESISTING CABLES AND  
CABLEGLANDS (Rated 110°C) AT  
AMB. TEMPERATURES OVER 40°C

Year of Construction /  
Serial No. i.e. 10 / 1DCB21000001

### 3) Type Approval Standards

The units have an EC Type examination certificate issued by KEMA and have been approved to the following standards:-

EN60079-0:2006 IEC60079-0:2004 (Ed4) General Requirements  
EN60079-1:2007 IEC60079-1:2007 (Ed6) Flameproof Enclosure 'd'

EN61241-0:2006 IEC61241-0:2004 (Ed1) Dust General  
Requirements  
EN61241-1:2004 IEC60079-1:2004 (Ed1) Dust Enclosures tD

### 4) Installation Requirements

The unit must be installed in accordance with the latest issues of the relevant parts of the EN60079 specifications or the equivalent IEC specifications – Selection, Installation and maintenance of electrical apparatus for use in potentially explosive atmospheres (other than mining applications or explosive processing and manufacture):-

EN60079-14:2008 Electrical Installations in Hazardous  
IEC60079-14:2007 (Ed4) Areas (other than mines)

EN60079-10:2003 Classification of Hazardous Areas  
IEC60079-10:2008 (Ed1)

The installation of the unit must also be in accordance with any local codes that may apply and should only be carried out by a competent electrical engineer who has the necessary training.

### 5) Zones, Gas Group, Category, IP Rating and Temperature Classification

The BExCBG05-05D unit has been certified Ex d IIB T4 for Ta -50°C to +70°C and Ex d IIB T5 for Ta -50°C to +55°C for gas and Ex tD A21 IP6X T100°C (Ta ≤ +55°C) or T115°C (Ta ≤ +70°C) for dust. This means that the units can be installed in locations with the following conditions:-

#### Area Classification Gas:

Zone 1	Explosive gas air mixture likely to occur in normal operation.
Zone 2	Explosive gas air mixture not likely to occur, and if it does, it will only exist for a short time.

#### Gas Groupings:

Group IIA	Propane
Group IIB	Ethylene

#### Temperature Classification:

T1	400° C
T2	300° C
T3	200° C
T4	135° C
T5	100° C

#### Area Classification Dust:

Zone 21	Explosive dust air mixture likely to occur in normal operation.
Zone 22	Explosive dust air mixture not likely to occur, and if it does, it will only exist for a short time.

**IP Rating:** IP67  
 T100°C Ta ≤ +55°C  
 T115°C Ta ≤ +70°C

**Equipment Category:** 2G/D

**Ambient Temperature Range:** -50°C to +70°C

## 6) Location and Mounting

The location of the unit should be made with due regard to the area over which both beacon warning signals must be visible. The unit should only be fixed to services that can carry the weight of the unit.

The unit should be securely bolted to a suitable surface using the 7mm diameter boltholes in the stainless steel U shaped mounting bracket (see figure 1). The angle can then be adjusted in the direction such that its warning signals can be both seen. This can be achieved by loosening the two large bracket screws in the side of the unit, which allow adjustment in steps of 18°. On completion of the installation the two large bracket adjustment screws on the side of the unit must be fully tightened to ensure that the unit cannot move in service.

### SAFETY WARNING:

**The flashdome guards must not be removed from the unit at any time.**

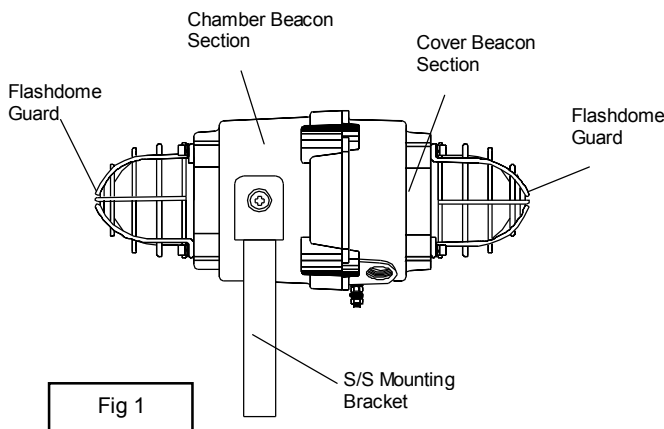

replacing the beacon section casting, ensure that it is square with the chamber beacon section before inserting. Carefully push the cover beacon section in place allowing time for the air to be expelled. Only after the cover beacon section casting is fully in place should the four M6 Stainless Steel A4-80 cover bolts and their spring washer be inserted and tightened down. If the cover beacon section jams while it is being inserted, carefully remove it and try again. Never use the cover bolts to force the cover beacon section casting into position.

In case of repair, contact the manufacturer for information on the dimensions of the flameproof joints.

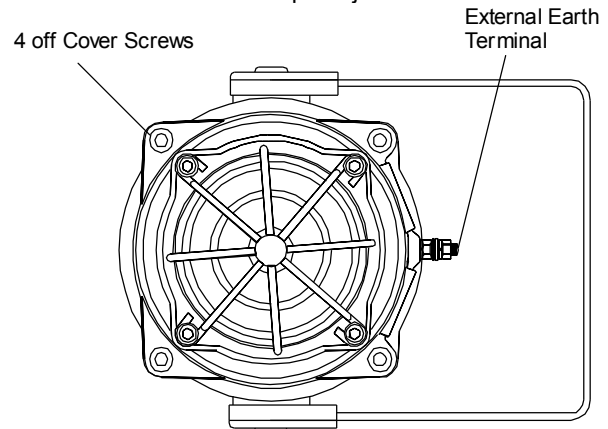

Fig 2

## Power Supply Selection

It is important that a suitable power supply is used to run the unit. The power supply selected must have the necessary capacity to provide the input current to all of the units connected to the system. The beacon sections can both be wired to the same power supply or to different power supplies

The following table shows the input current taken by each beacon section of the various units:-

Unit Type	Input Voltage	Chamber Beacon Current	Max. I/P Volts
BExCS110-05D	24V DC	300mA	30V
BExCS110-05D	12V DC	750mA	15V
BExCS110-05D	48V DC	1800mA	58V
BExCS110-05D	230V AC	55mA	253V
BExCS110-05D	115V AC	140mA	126V

Unit Type	Input Voltage	Cover Beacon Current	Max. I/P Volts
BExCS110-05D	24V DC	300mA	30V
BExCS110-05D	12V DC	750mA	15V
BExCS110-05D	48V DC	1800mA	58V
BExCS110-05D	230V AC	55mA	253V
BExCS110-05D	115V AC	140mA	126V

The above table also shows the maximum voltages at which the units can be operated.

The circuits of each beacon section are the same. The input current to each beacon section will vary according to the voltage input level. The current levels shown above are for nominal input voltage. The 12V, 24V and 48V DC units have a converter circuit and therefore the input current level will

## 7) Access to the Flameproof Enclosure

In order to connect the electrical supply cables to the unit it is necessary to remove the cover beacon section to gain access to the flameproof chamber. To achieve this remove the four M6 hexagon socket head screws (see figure 2) and withdraw the cover beacon section taking extreme care not to damage the flameproof joints in the process.

Note the four **M6 screws are Class A4-80 stainless steel and only screws of this category can be used on these units.** It is therefore important that these screws and their spring washers are kept in a safe place during installation.

On completion of the cable wiring installation the flameproof joints should be inspected to ensure that they are clean and that they have not been damaged during installation. Also check that the earth bonding wire between the two casting sections is secure and the 'O' ring seal is in place. When

decrease slightly as the input voltage is increased and will increase slightly as the input voltage is reduced.

## 8) Cable Selection

When selecting the cable size consideration must be given to the input current that each unit draws (see table above), the number of units on the line and the length of the cable runs. The cable size selected must have the necessary capacity to provide the input current to all of the units connected to the line.

**SAFETY WARNING:** If the unit is used at high ambient temperatures, i.e. over +40°C, then the cable entry temperature may exceed +70°C and therefore suitable heat resisting cables must be used, with a rated service temperature of at least 110°C.

## 9) Earthing

Both AC and DC units must be connected to a good quality earth. The units are provided with internal and external earthing terminals, which are both, located on the beacon section of the unit (see figures 2 and 3).

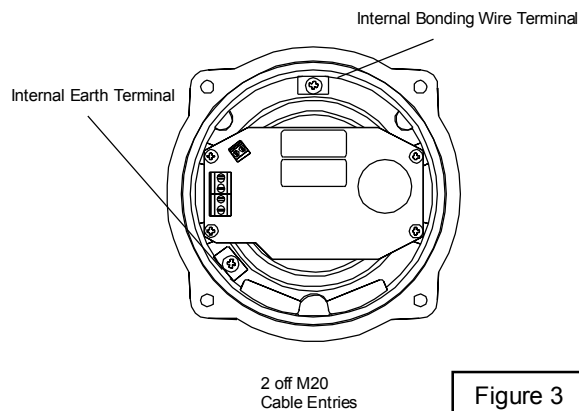

Figure 3

When using the internal earth terminal ensure that the stainless steel M4 flat washer is between the incoming earth wire and the enclosure.

When using the external earth terminal a cable crimp lug must be used. The cable lug should be located between the two M5 stainless steel flat washers. The M5 stainless steel spring washer must be fixed between the outer flat washer and the M5 stainless steel nut to ensure that the cable lug is secured against loosening and twisting.

The internal earth bonding wire ensures that a good quality earth is maintained between the sounder section casting and the beacon section casting.

## 10) Cable Glands

The BExCBG05-05D unit has dual cable gland entries which have an M20 x 1.5 entry thread as standard or a PG13.5 thread as a special. Only cable glands approved for Ex 'd' applications can be used, which must be suitable for the type of cable being used and also meet the requirements of the Ex 'd' flameproof installation standard EN60079-14:2008 / IEC60079-14:2007.

When only one cable entry is used the other one must be closed with an Ex 'd' flameproof blanking plug, which must be suitably approved for the installation requirements.

For combustible dust applications, the cable entry device and blanking elements shall be in type of explosion protection increased safety "e" or flameproof enclosure "d" and shall have an IP 6X rating according to EN60529:1992

**SAFETY WARNING:** If the unit is used at high ambient temperatures, i.e. over +40°C, then the cable entry temperature may exceed +70°C and therefore suitable heat resisting cable glands must be used, with a rated service temperature of at least 110°C.

## 11) Cable Connections

The combined beacon / beacon unit BExCBG05-05D has separate printed circuit boards for each beacon section. The terminals for the chamber beacon are on the printed circuit board in the chamber beacon section and the terminals for the cover beacon are on the printed circuit board in the cover beacon section (see figures 4&5 and 6&7). See section 7 of this manual for access to the enclosure and the wiring diagrams at the end of this manual.

Both beacon sections can be wired to the same input supply so that they operate simultaneously or they can be wired to separate input supplies so they can be operated independently (see diagrams of pages 4 and 5 of this manual). If the beacon sections are connected to the same input supply, the incoming cables should be connected to the input terminals on the cover beacon board and the two connecting wires, that are supplied with the unit, should be used to link the supply from the interconnecting terminals on the cover beacon board down to the supply terminals on the chamber beacon board.

### CHAMBER BEACON SECTION CONNECTIONS

The cable connections are made into the terminal blocks on the electronic pcb assembly located in the chamber beacon section enclosure. A four-way terminal block is provided on both AC and DC beacons. Therefore there are two live terminals and two neutral terminals for the input and output wiring on AC units. On the DC units there are two +ve terminals and two -ve terminals for the input and output wiring. (see figure 6).

Wires having a cross sectional area of up to 4mm<sup>2</sup> can be connected to each terminal way. When connecting wires to the terminals great care should be taken to dress the wire so that when the cover beacon section is inserted into the chamber the wires do not exert excess pressure on the terminal blocks. This is particularly important when using cables with large cross sectional areas such as 2.5mm<sup>2</sup> and above. If both beacons are wired to the same power supply always use the flexible interconnecting wires provided.

### COVER BEACON SECTION CONNECTIONS

The cable connections are made into the terminal blocks on the electronic pcb assembly located in the cover beacon section enclosure. A four-way terminal block is provided on both AC and DC beacons. Therefore there are two live terminals and two neutral terminals for the input and output wiring on AC units. On the DC units there are two +ve

terminals and two -ve terminals for the input and output wiring.

Wires having a cross sectional area of up to 4mm<sup>2</sup> can be connected to each terminal way. When connecting wires to the terminals great care should be taken to dress the wires so that wires do not exert excess pressure on the terminal blocks. This is particularly important when using cables with large cross sectional areas such as 2.5mm<sup>2</sup> and above.

**BExCBG05-05D AC Cover Beacon Section**

Interconnecting Terminals to chamber beacon pcb (simultaneous or flip flop mode of operation)

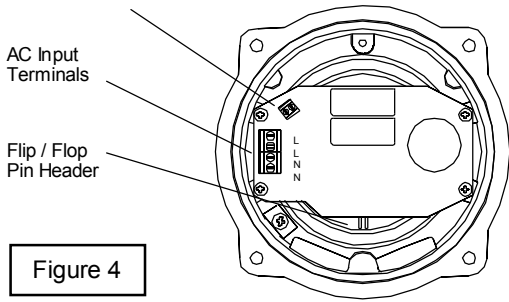

Figure 4

**BExCBG05-05D DC Cover Beacon Section**

Interconnecting Terminals to chamber beacon pcb (simultaneous or flip flop mode of operation)

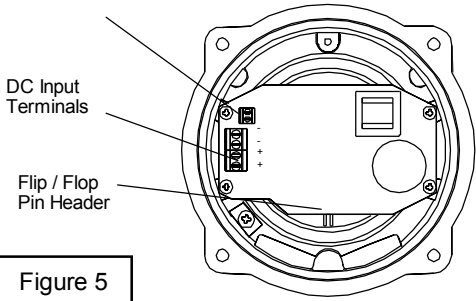

Figure 5

**BExCBG05-05D Chamber Beacon Section**

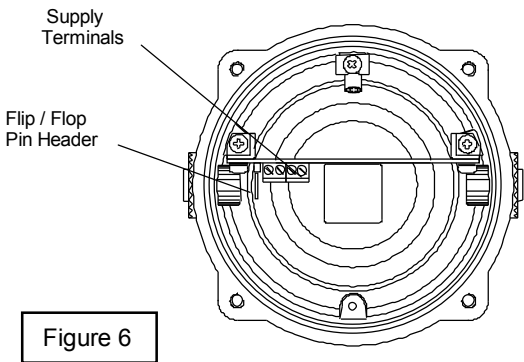

Figure 6

On BExCBG05-05D DC units, dc reverse line monitoring can be used if required. All DC units have a blocking diode fitted in their supply input lines on both beacon sections. An end of line monitoring diode or an end of line monitoring resistor can be connected across the +ve and -ve terminals. If an end of line resistor is used it must have a minimum resistance value of 3k3 ohms and a minimum wattage of 0.5 watts or a minimum resistance value of 500 ohms and a min. wattage of 2 watts. If the beacon sections are wired to separate power supplies then an end of line monitoring component can be used in each section.

**13) Synchronised Operation**

All BExCBG05-05D units that are connected to the same supply line will have a synchronised flash rate at one flash every second. To ensure that the units will be synchronised check that the pin header is not fitted, i.e. the two header pins are not shorted together (see Figures 4 and 5).

**14) Flip / Flop Operation**

The two beacon sections can be set to form a flip-flop operation, where the beacons will flash alternately. To achieve this mode of operation, fit a pin header to the flip-flop header pins on one of the electronics board, i.e. the two header pins are shorted together, (see figures 4 to 6). The first flash on the beacon that has the header fitted will be delayed by 1/2 second. The two beacons will then flash alternately every 1/2 a second.

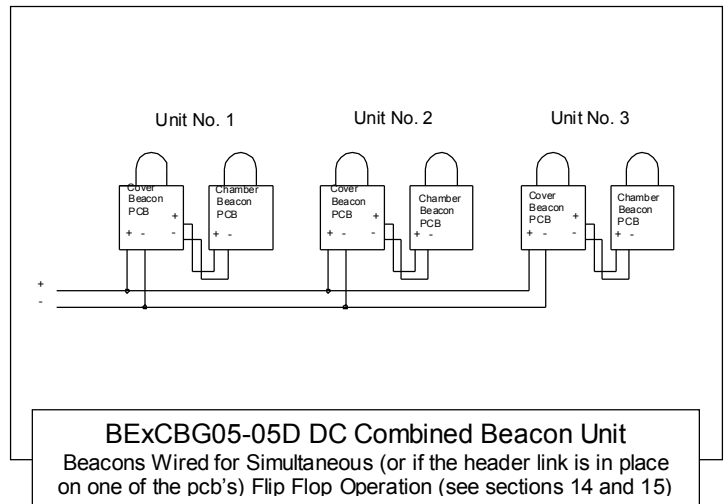

**12) End of Line Monitoring (DC Units)**

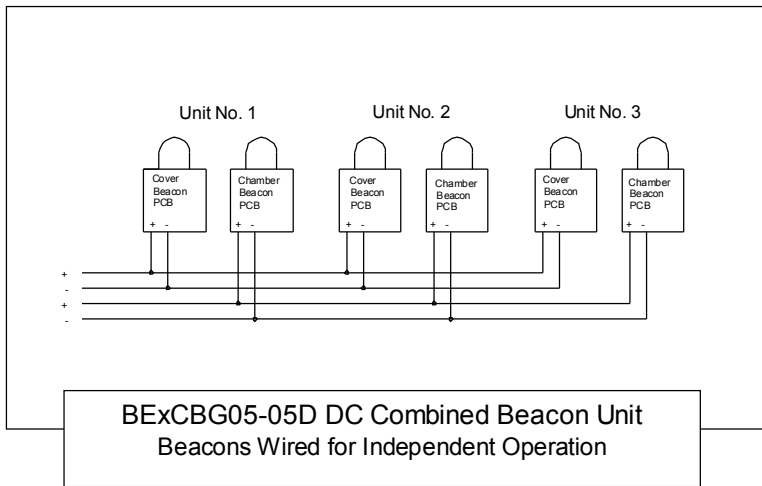

**NOTE**  
 Either the +ve or the -ve wire may be made common to both the chamber and cover beacons to reduce the number of cores in the cable.

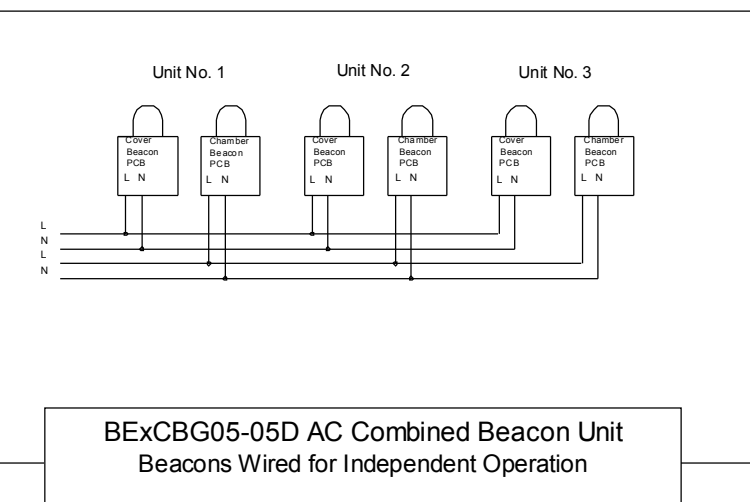
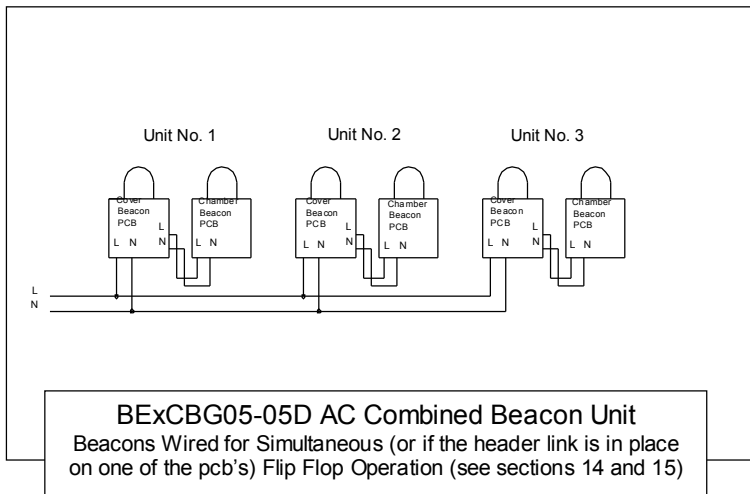

**NOTE**  
 Either the L or the N wire may be made common to both the sounder and the beacon to reduce the number of cores in the cable.

# EC DECLARATION OF CONFORMITY



**Manufacturer:** European Safety Systems Ltd.  
Impress House, Mansell Road, Acton  
London, W3 7QH, UK

**Equipment Type:** BExCBG05-05D

---

## Directive 94/9/EC: Electrical and Mechanical equipment for use in explosive atmospheres (ATEX)

**Notified Body for EC type Examination:** KEMA Quality B.V.  
Notified Body No.: 0344  
Utrechtseweg 310, 6812 AR Arnhem, The Netherlands

**EC-type Examination Certificate:** KEMA 01ATEX2222X

**Notified Body for Quality Assurance Notification:** Sira Certification Service  
Notified Body No.: 0518  
Rake Lane, Eccleston, Chester CH4 9JN, UK

**Quality Assurance Notification:** SIRA 05 ATEX M342

**Provisions fulfilled by the equipment:** II 2 G Ex d IIB T4 or T5  
II 2 D Ex tD A21 IP6X T100 °C or T115 °C

**Standards applied:** EN 60079-0:2006  
EN 60079-1:2007  
EN 61241-0:2006  
EN 61241-1:2004

## Directive 2004/108/EC: Electromagnetic Compatibility Directive (EMC)

**Standards applied:** EN 61000-6-1:2007  
EN 61000-6-2:2005  
EN 61000-6-3:2007  
EN 61000-6-4:2007

---

The standards EN 60079-0: 2006, EN 61241-0:2006 and EN 61241-1:2004 are no longer harmonized. The requirements of these standards have been checked against the harmonized standards EN 60079-0:2009 and EN 60079-31:2009 and there were no major technical changes affecting the latest technical knowledge for the products listed above.

On behalf of European Safety Systems Ltd., I declare that, on the date the equipment accompanied by this declaration is placed on the market, the equipment conforms with all technical and regulatory requirements of the above listed directives.

A handwritten signature in black ink, appearing to read 'Martin Streetz', written over a light blue circular stamp.

**Martin Streetz**  
Quality Assurance Manager

**Date and Place of Issue:** London, 04/07/2012  
**Document No:** DC-006-Issue\_C