

BExL25/BExDL25 PA Loudspeakers 25W

The flameproof BExL25 PA loudspeakers are suitable for Zone 1 & Zone 2 applications and the BExDL25 sounders also for Zone 21 & 22.

The BEx range features enclosures manufactured from corrosion proof, marine grade copper free LM6 aluminium which is phosphated and powder coated.

The re-entrant flare horns are high impact, fire retardant ABS. All models have two M20 cable entries, large termination areas containing in & out terminals (Ex de version only) and an ingress protection of IP66/67 (Ex d) and IP66 (Ex de).

An independent test report is available on request, or online, detailing the performance of the BEx loudspeaker range.

Features

- Very large termination area.
- Ratchet adjustable stainless steel 'U' bracket.
- IN & OUT terminals (Ex de version only).

Approvals

- ATEX certificate: KEMA 99ATEX6312, EN 60079-0 : 2006, EN 60079-1 : 2007, EN 60079-7 : 2003, EN 61241-0 : 2006, EN 61241-1 : 2004
- IECEx certificate: IECEx KEM 10.0003, IEC 60079-0 : 2004 (Ed4), IEC 60079-1 : 2007 (Ed6), IEC 60079-7 : 2001 (Ed3), IEC 61241-0 : 2004 (Ed1), IEC 61241-1 : 2004 (Ed1)
- GOST-R certificate: POCC GB.JB05.B03365
- Safety integrity suitability: SIL1
- Inmetro certificate: 10IEx-0009



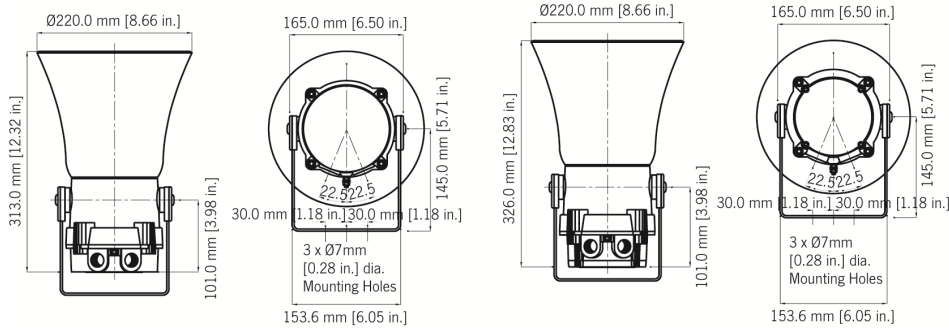

Specification

SPL:	105dB +/-3dB @ 1w @ 1m (Pink) 119dB +/-3dB @ 25w @ 1m (Rated)
Rated power:	25 Watts RMS
70v line tapings:	25w / 12.5w / 6w / 2w tapings (z=196 Ohms /392 Ohms / 816.67 Ohms / 2.45k Ohms)
100v line tapings:	25w / 12.5w / 6w / 2w tapings (z=400 Ohms /800 Ohms / 1.67k Ohms / 5k Ohms)
Low impedance:	8 Ohm or 16 Ohm
Dispersion:	130° @ 1kHz & 32° @ 4kHz
Frequency range:	300Hz to 8000 Hz
DC Line monitoring:	2.2µF Capacitor (Transformer) 470µF Capacitor (Impedance)
Ingress protection:	L25D : IP66/67 L25E : IP66
Housing material:	Marine grade copper free LM6 Aluminium
Housing finish:	Phosphated & powder coated finish - anti-corrosion.
Colour:	RAL3000 Red (others available on request)
BEExL25 flare:	High impact UL94 V0 & 5VA FR ABS (Red)
BEExDL25 flare:	Anti-Static High impact ABS (Black)
Cable entries:	Dual M20 ISO (one stopping plug inc)
Terminals:	0.5 to 2.5mm ² cables.
Weight:	70/100V line: 3.95kg/8.69lbs Low imp.: 3.56kg/7.83lbs

Part Codes

Part Code:	Classification:
BEExL25D**	ATEX / IECEx: II 2G Ex d IIB T4 Ta. -50° to +70°C II 2G Ex d IIC T4 Ta. -50° to +55°C GOST-R: 1ExdIICT4 Ta. -50° to +55°C
BEExL25E**	ATEX / IECEx: II 2G Ex de IIB T4 Ta. -50° to +70°C II 2G Ex de IIC T4 Ta. -50° to +55°C GOST-R: 2ExdeICT4 Ta. -50° to +55°C
BEExDL25D**	ATEX / IECEx: II 2G Ex d IIB T4 Ta. -50° to +70°C II 2G Ex d IIC T4 Ta. -50° to +55°C II 2D Ex tD A21 IP67 T115 based on a max. Ta. of 70°C GOST-R: 1ExdIICT4 Ta. -50° to +55°C T100°C DIP A21 Ta T4
BEExDL25E**	ATEX / IECEx: II 2G Ex de IIB T4 Ta. -50° to +70°C II 2G Ex de IIC T4 Ta. -50° to +55°C II 2D Ex tD A21 IP66 T115 based on a max. Ta. of 70°C GOST-R: 2ExdeICT4 Ta. -50° to +55°C DIP A21 Ta T4

**** = type reference:

Options:	70V	70V Line transformer
	100V	100V Line transformer
	8R	8 Ohm low impedance
	16R	16 Ohm low impedance

e.g: BEExL25D100V

AUTHORIZED DISTRIBUTOR:
GasDetectorsUSA.com
Houston, Texas USA
sales@GasDetectorsUSA.com
832-615-3588