

B200LDA LED Permanent Beacon

The B200 series is comprised of a Xenon strobe beacon, permanent filament bulb, blinking filament bulb and a permanent LED array beacon version.

The surface mount base can also be supplied with a right angle bracket or with a pole mounted assembly.

Features

- Bayonet fixing lens.
- Anti-tamper locking screw.
- Stainless steel fixings.

Approvals

- GOST-R certificate: POCC GB.JB05.H00144.



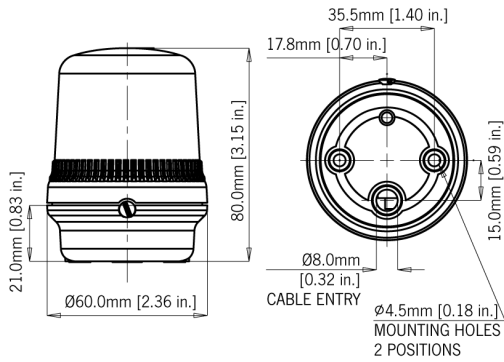

Specification

Light source:	9 x High power L.E.D.'s
Lens/L.E.D. colours:	Amber, Blue, Clear (White L.E.D), Green, Red & Yellow
Lens type:	Prismatic (standard) or plain
Peak/Effective Intensity cd:	5.5 cd* - measured ref. to I.E.S.
Mounting:	Surface mount (right angle or pole mount accessories available)
Ingress protection:	IP65
Housing material:	High impact UL94 V0 (f1) PC
Lens material:	High impact UL94 V0 (f1) PC
Terminals:	0.5 to 1.5mm ²
Operating temp:	-25 to +50°C [-13 to +122 °F]
Storage temp:	-40 to +70°C [-40 to +158°F]
Relative humidity:	90% at 20°C [68°F]
Weight:	78g/1.71lbs

*Candela measurements representative of performance with clear lens at optimum voltage

Part Codes

Version:	Part code:
10-30V dc	B200LDA030B/[x]
90-230V ac	B200LDA230B/[x]

[x] = Lens colour: A: Amber
B: Blue
C: Clear
G: Green
R: Red
Y: Yellow

Current Consumption

Version:	Current m A:
10-30V dc	80mA
90-230V ac	50/60Hz 32mA

AUTHORIZED DISTRIBUTOR:
GasDetectorsUSA.com
Houston, Texas USA
sales@GasDetectorsUSA.com
832-615-3588