

GazTell

Fixed Point Oxygen Deficiency Electrochemical Detector Head with EXMO and SLAM

Reference:

Quotation No:

Date:

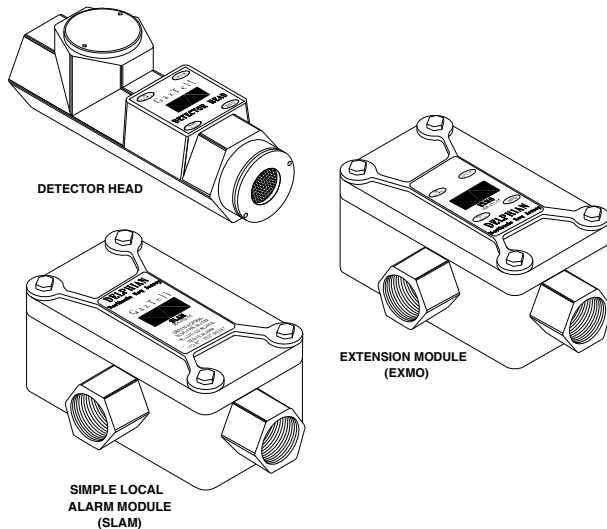

Assembly Design

- Modular component design: detector head can be used alone or with the EXMO (extension module) which will display all the information from the detector head and perform all of its functions. The optional SLAM has relays for Fail, Low and High alarms and has a multi-color LED for system alerts.
- 100% quality tested.
- The detector head (and extension module) shows system warnings and failures.
- Built-in selftest continuously monitors hardware and software.
- Calibration required infrequently.
- RFI and surge protection circuits built in.
- Options include Splash/Dust Guard, Ported Adaptor, Reclamation Adaptor, Collection Cone, Wye Pipe Adaptor, Duct Mounting Plate, Lightning Arrestor and MODBUS RTU Communications Module (COMO).

Construction

- Stand-alone. Modular construction which makes wiring easy and permits rapid replacement of components.
- Sensor and conduit box are explosion proof.
- The internal sensor components and all connectors exposed to the atmosphere are gold plated.
- All connectors are unique and are keyed to prevent incorrect connections.
- The detector electronics are encapsulated to prevent deterioration from dust and humidity.
- No moving parts.

Specifications

Dimensions:	Detector Head	5"L x 2"W
	EXMO	6"L x 3.5"W x 2"H
	SLAM	6"L x 3.5"W x 2"H
Shipping Weight:	Detector Head	.875 lbs (.4 kg)
	EXMO	1.25 lbs (.6 kg)
	SLAM	1.25 lbs (.6 kg)
Power:	Detector Head	40mA max
	EXMO	16mA max
	SLAM	56mA max

Output Signal:

Range 4 - 20mA or 1 - 5mA (4 - 20mA is default)
Output is linear and proportional to the gas scale.
Load (maximum resistance) 300 Ohms

Scale (Detection Range):

0 - 21% by volume (0% = 4.0mA, 21% = 20mA),
over range to 22mA (23.6%)

Cell Operating Range: 0 to 25% oxygen

Saturation (Maximum Overload): 30% oxygen

Temperature Range:

Continuous Operating Temperature Range: -30°C to +50°C (-22°F to +122°F)

Storage Temperature Range: 0°C to +20°C (+32°F to +68°F)

Poisoning Gases:

High concentrations of solvent vapors, alcohols, phenols, pyridine, ketones, amines, acetylene and chlorinated solvents can attack the cell.

Expected Operating Life in Air at 70°F: >24 months

Once cell is installed in a powered Detector Head it will be active and begin to use up its useful life. Long exposure to oxygen over 21% will reduce its life.

Operating Pressure Range: Atmospheric +/- 10%

Operating Relative Humidity Range:

5 - 95% RH (relative humidity) non condensing (continuous).

Response Time:

When exposed to a step change from 21% to 5% oxygen, the detector head will register less than 16% within 11 seconds.

Recovery Time:

When exposed to 5% oxygen, Detector Head will return to, at least 19% within 30 seconds.

Accuracy: 1% of actual oxygen concentration

Repeatability: 0.5% of reading.

Resolution: 0.1% oxygen

Long Term Drift: <5% per year

Warm-up Time: Less than 1 minute to operational.

Stabilization Time:

Initial stabilization time to specification may take from 4 to 12 hours depending on ambient conditions.

Warranty Period:

12 months in Air at S.T.P. (from date of shipment)

SLAM Relays: 6 amps @ 120 volts

SLAM Response Time:

Less than a second from the time the Detector Head sees sufficient gas to trigger an alarm to the relay operating.

EXMO Response Time:

Less than a second from the time the Detector Head sees gas to the EXMO displaying that gas concentration.



DELPHIAN CORPORATION

220 Pegasus Avenue, Northvale, NJ 07647 U.S.A.

Tel: 201-767-7300 Fax: 201-767-1741

www.delphian.com

DELPHIAN

NOTICE: The information in this document is subject to change without notice. Not all possible interfering, blocking or poisoning gases have been tested. This document is provided in good faith but without warranty of any kind. It could include technical inaccuracies or typographical errors. The GazTell Owners Manual should be consulted if more information is required.