

Manual for Installation

aSENSE™ m III

in industrial wall mounted housing
CO₂ / CO sensor with built-in general purpose
controller

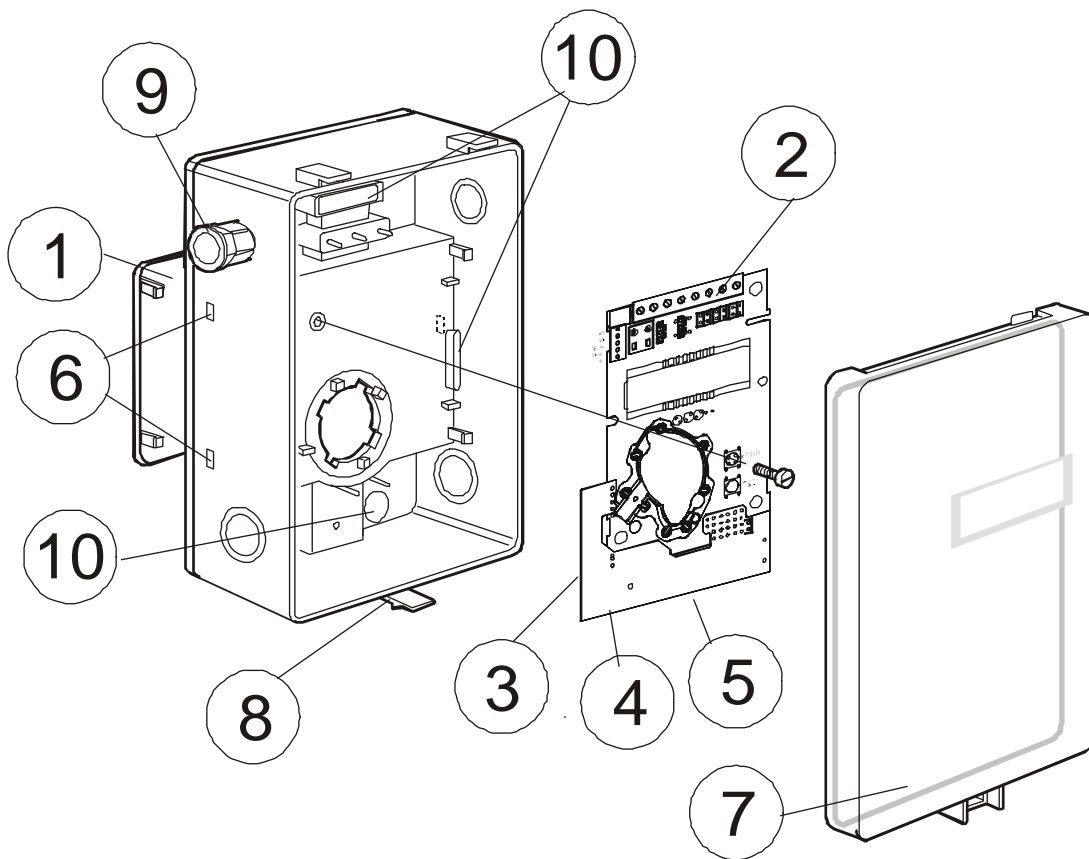

Fig. 1

- | | | | |
|---|--|----|--------------------------------------|
| 1 | Wall plate | 5 | Carbon monoxide sensor (not shown) |
| 2 | PCB (Factory supplied mounted in box) | 6 | Hole for wall plate hooks |
| 3 | Temperature sensor for internal compensation (not shown) | 7 | Snap-in lid |
| 4 | RH sensor for internal compensation (not shown) | 8 | Locking screw of the lid (not shown) |
| | | 9 | PG9 cable entry bushing |
| | | 10 | Air holes |

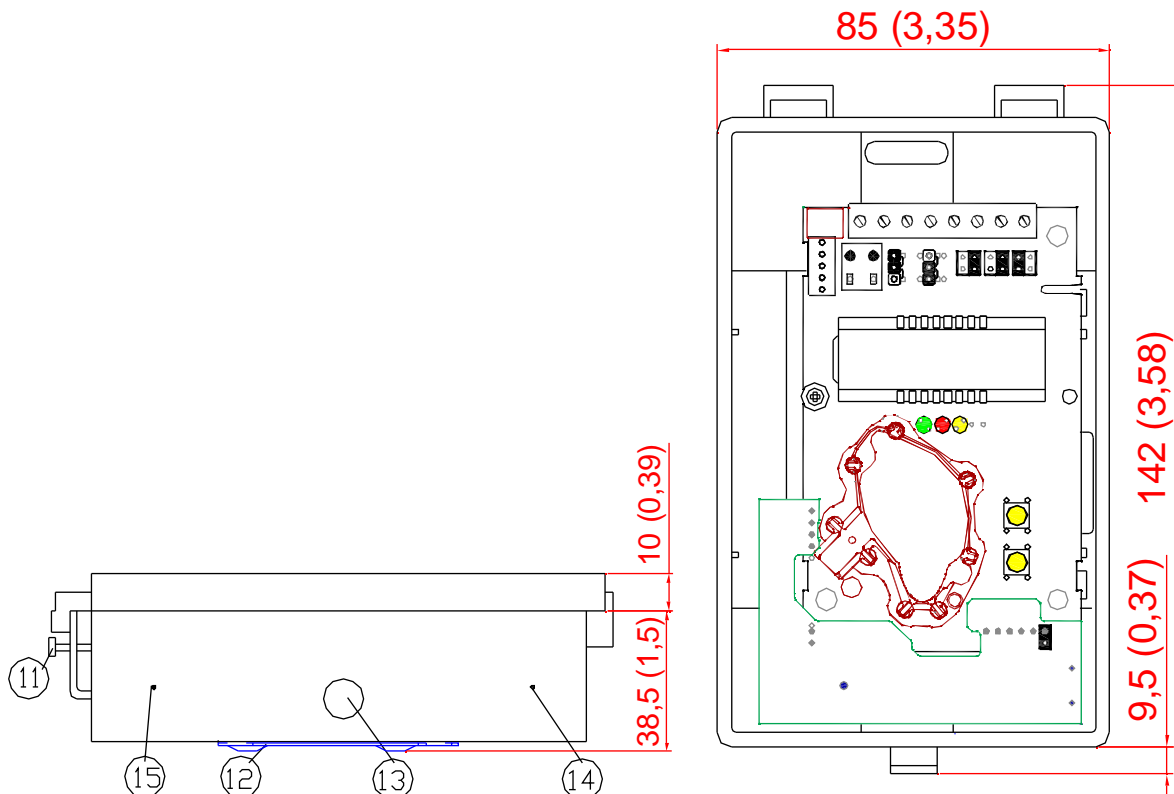

Fig. 2

11 Lidlocking screw

12 Wall plate

13 Screw to hold the wall plate

14 Marking to drill hole for PG7

15 Marking to drill hole for PG9

Wall Mounting Instruction

1. **Dismount the wall plate.** The sensor is delivered with the wall plate mounted. The wall plate has to be removed before the sensor is mounted onto the wall. Unscrew the screw on the side of the box. See figure 3.
2. **Screw the wall plate onto the wall.** The sensor should be mounted 1 to 1,8 m above the floor. The wall plate has holes for three screws. Drill holes for 3,5mm screws and put dowel into them. Dowels and screws 3,5 x 25mm are included in a plastic bag
3. **Attach the sensor box** to the wall plate. It is done by a snap-in fitting. The wall plate has three hooks that fit in holes in the sensor box. Fasten the screw on the side of the box.
4. **Electrical cable entry.** The box has a factory mounted cable entry bushing in dimension PG9. Never feed more than one cable through each cable entry bushing, or else gas might leak through!

The lid can be locked with the screw (11) at the bottom of the sensor box.



Please note! Normally the PCB should not be removed from the housing. If for some reason the PCB must be removed it must be handled carefully and protected from electrostatic discharge.

Electrical connections

The power supply has to be connected to G+ and G0. G0 is considered as system ground. The same ground reference has to be used for the aSENSE™ m III unit and for any connected device! Unless different transformers are used, special precautions need to be taken.

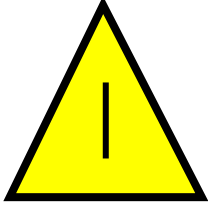

PLEASE NOTE! The signal ground is not galvanically separated from the aSENSE™ m III power supply!

PLEASE NOTE! The same ground reference has to be used for the aSENSE™ m III unit and for the control system!

Connection Terminal	Function	Electrical Data	Remarks
G+	Power (+)	24 VAC/DC+ (+-20%), 3W	2W without output load See note 1!
G0	Power ground (-)	24 VAC/DC-	
OUT 1	Analogue Output 1 (+)	0-10 VDC or 0-20 mA, 2-10 VDC or 4-20 mA,	According to positions of OUT1 jumper and start point selection. See note 2!
OUT 2	Analogue Output 2 (+)	Same as Output 1	According to positions of OUT2 jumper and start point selection. See note 2!
M	Signal Ground (-)	Connected to G0 via PTC fuse	See note 1!
Relay	Normally closed	Contact free relay minimum load 1mA/5V	Triggered by register OUT3
Relay	Open at alarm situations and power loss	rated load 0,5A/125VAC; 1A/24VDC	
OUT4	Analogue Output 4 (+) or Open Collector	0-10 VDC Max 0,5A, 55VDC / 40VAC (half-wave rectifier protection)	According to positions of OUT4. See note 2 & 3!
DI1	Digital Input 1	Closed contact current 1mA Open contact voltage max 5V	Do not apply any voltage on this input!

Table I. Electrical terminal connections for aSENSE™ m III

Note 1: The ground terminal is used as negative power supply DC input or AC phase ground G0 (halfwave rectifier). The signal ground M, protected by a PTC resistor, is the same as power ground G0 (permitting a "3-wire" configuration). A single transformer may be used for the entire system.

Note 2: aSENSE™ m III can deliver both a voltage or a current loop for OUT1/OUT2. For OUT4 a voltage output or an open collector output is selected with jumper OUT4. To change between voltage and current output mode the hardware jumpers are used. There is one jumper for OUT1 and one for OUT2, so that one output can be a voltage output and the other a current output. Both, voltage output and current output, can have start points 0 % (0-10 VDC or 0-20mA) or 20% (2-10 VDC or 4-20mA) selected from PC software. See the function manual.

Note 3: Current of Open Collector is internally returned to G0 terminal.

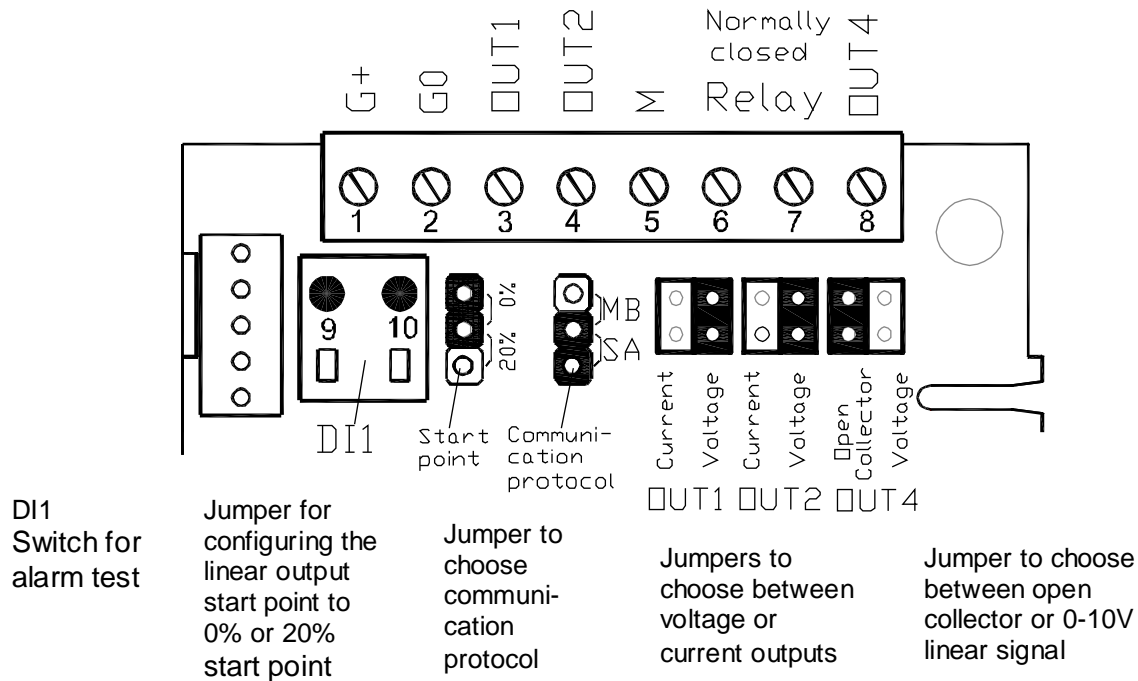

Fig. 3. Terminals and jumpers on *aSENSE™ m III*. The darker positions are default settings.

No.	Label	Function (configurable)
3	OUT1	CO-transm. 0...100 ppm
4	OUT2	CO ₂ -transm. 0...2000 ppm
6, 7	OUT3	Gas alarm CO >35 ppm or CO ₂ >1500 ppm
8	OUT4	Drift disturbing alarm or gas alarm
9, 10	DI 1	Extra terminal. Test function (N.O.)

If more holes are needed the box has several drill markings for holes in two dimensions, PG7 and PG9. Then fasten the cable entry bushing and seal properly. Never feed more than one cable through each cable entry bushing, or else gas might leak through!

The PCB can be removed during the making of holes. The PCB must be handled carefully and protected from electrostatic discharge!

If the PCB is in the housing when the hole is made a background calibration, CALb, using the push buttons should be made. See the function and maintenance description.

Start-up of the *aSENSE™ m III*

Connect the power directly after mounting. The unit works best if the sensor is continuously powered. The analogue outputs do not need to be connected before use. An internal delay function prevents the alarm functions of the relay and OUT4 output during 15 minutes after power up. After short power failures the CO measurements need this power up time to stabilize. The alarm outputs may be tested after the 15 minutes delay by shorting the switch DI1. After long power failures the sensor may need several days to restore the measuring functions.



NOTE! The CO probe gives incorrect readings near some chemicals, e.g. silicone. This makes certain environments unsuitable for the sensor.