

# Quickstart Guide

## GASMAX II / GDS-IR Gas Monitor



### INSTALLATION

**IMPORTANT - Before installing the GASMAX II / GDS-IR, make sure there are no toxic or combustible gases are present. Declassify the area if necessary.**

Factors such as air movement by fans, prevailing winds, convection, gas density, emission sources and environmental variables should be taken into account when determining sensor location. As with all sensors, the GASMAX II / GDS-IR should be protected from falling or directed water, shock, vibration and dirt.

The GDS-IR sensor may be mounted either horizontally or vertically (preferred). If mounted horizontally, make sure the GDS-IR is protected from dripping water.

Use conduit and installation practices approved for the appropriate area classification. When installed correctly, the GASMAX II / GDS-IR is certified for use in areas rated Class 1, Div 1, Groups B, C & D.

### POWER & 4-20mA WIRING

Locate the GASMAX power supply board. The board is attached to the inside of the GASMAX explosion-proof housing (see Figure 1).

Connect the +DC power wire to TB2 pin 1. Connect the -DC power to TB2 pin 4. The allowable DC voltage range is 18 to 30 VDC.

The GDS-IR calibrated 4-20mA output signal is available at TB2 pin 3. (If an optional electrochemical sensor is also connected to the GASMAX Echem input, the Echem sensor 4-20mA output is available on TB2 pin 2).

### RS-485 DIGITAL WIRING

Locate the GASMAX II alarm / MODBUS board. The board is attached to the back of the GASMAX II removable electronics assembly.

Attach the two RS-485 signal cables to TB2 pins 1 & 2. Attach the signal shield wire to TB2 pin 3. **NOTE:** RS-485 is polarity-sensitive and the wires on pins 1 & 2 may need to be swapped for proper operation. If wiring in a "daisy chain", terminals 4 & 5 are available for outgoing RS-485 wiring.

If necessary, select Jumper 1 (J1) position "A" to enable the RS-485 termination resistor. This is typically done on the device furthest from the RS-485 master controller.

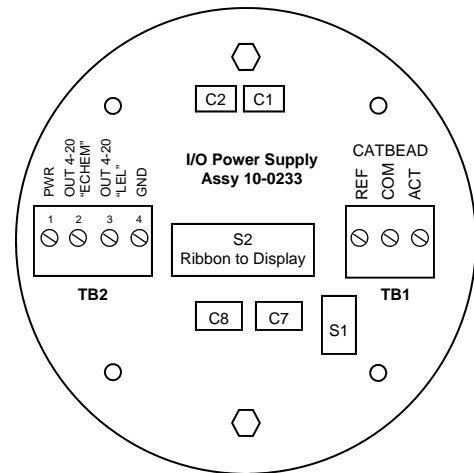

Fig 1. GASMAX Power Supply Board

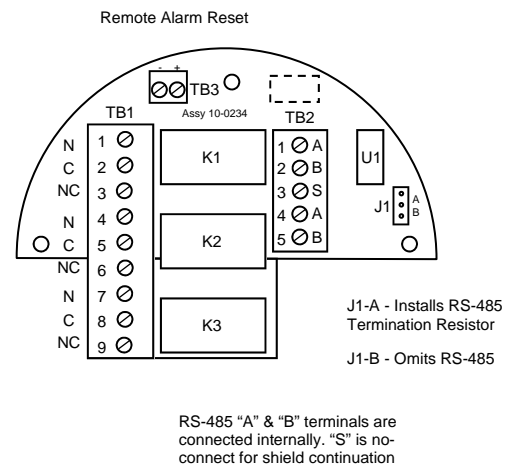

Fig 2. GASMAX Alarm / MODBUS Board

## INITIAL STARTUP & AUTO ZERO

Apply power to the GDS-IR / LPI and allow the instrument to stabilize for at least one (1) hour.

**IMPORTANT - Ensure there is no combustible gas present during the auto-zero procedure. Apply a flow of nitrogen or known 'zero air' if necessary. Setting zero with background target gas will cause erroneous readings.**

Using a magnetic wand, activate the auto-zero switch located behind the RED conduit end-cap. Hold the wand in place for at least 10 seconds, but not more than 20 seconds. The GASMAX display should momentarily indicate "IR ZERO" when the GDS-IR output drops to 2.2mA to indicate a successful zero setting.

## CALIBRATION

Attach a calibration cup to the sensor head and apply a steady flow of "zero air" to the instrument for one minute. Hold the magnetic wand over the "DN / CAL" switch on the lower left side of the display until the GASMAX enters calibration mode. Follow the on-screen instructions to calibrate the GASMAX II / SmartIR unit.

## CLEANING

To clear an Optics Fault, first try a zero calibration. If the calibration does not correct the fault condition, clean the optics. The outer barrel (tube with two sets of holes) can be removed (unscrewed) to inspect the cleanliness of the hydrophobic filter. The hydrophobic filter is a Teflon coated stainless steel mesh that keeps moisture and particulates out of the optical path. A setscrew holds the filter to the GDS-IR housing. Once the hydrophobic filter is removed, the internal waveguide tube should be inspected for cleanliness. The waveguide and waveguide collar can be removed by inserting rigid instruments such as Allen wrenches into one hole of the waveguide and one hole of the collar. Turning the two instruments in opposite directions will loosen the waveguide allowing the collar to be screwed down on to the waveguide until it can be removed from the GDS-IR housing. Clean the two sapphire windows with a lint-free cloth and reassemble the unit. Perform an auto zero procedure as described above.

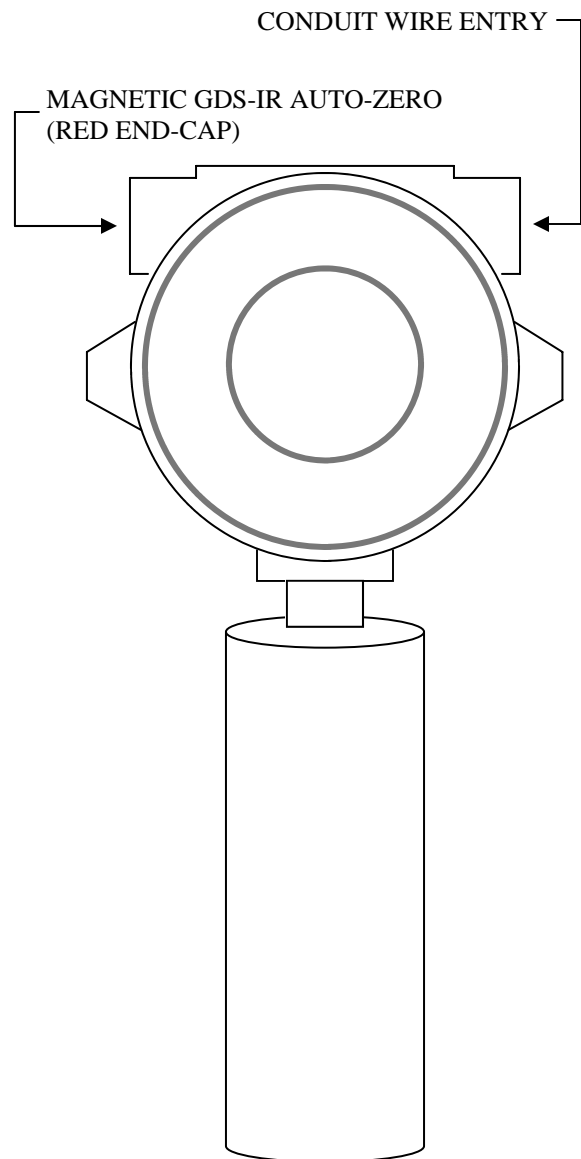

Fig 3. GASMAX II / GDS-IR  
(standard configuration)

## SPARE PARTS & ACCESSORIES

10-0271	Sample flow cell assembly
10-0270	Sensor duct mount
10-0193	Remote sensor head junction box

### GDS Corp.

2513 Hwy 646

Santa Fe, Texas 77510

(409) 927-2980 (409) 927-4180 fax

www.gdscorp.com info@gdscorp.com