

Quickstart Guide

GASMAX II / SmartIR Gas Monitor



INSTALLATION

IMPORTANT - Before installing the GASMAX II / SmartIR, make sure there are no toxic or combustible gases are present. Declassify the area if necessary.

Factors such as air movement by fans, prevailing winds, convection, gas density, emission sources and environmental variables should be taken into account when determining sensor location. As with all sensors, the GASMAX II / SmartIR should be protected from falling or directed water, shock, vibration and dirt.

The SmartIR sensor may be mounted either horizontally or vertically (preferred). If mounted horizontally, make sure the SmartIR is protected from dripping water.

Use conduit and installation practices approved for the appropriate area classification. When installed correctly, the GASMAX II / SmartIR is certified for use in areas rated Class 1, Div 1, Groups B, C & D.

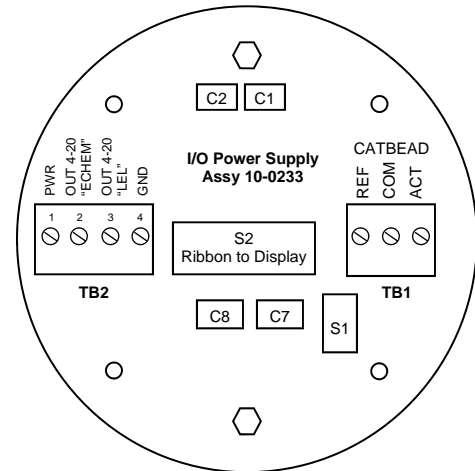

Fig 1. GASMAX Power Supply Board

POWER & 4-20mA WIRING

Locate the GASMAX power supply board. The board is attached to the inside of the GASMAX explosion-proof housing (see Figure 1).

Connect the +DC power wire to TB2 pin 1. Connect the –DC power to TB2 pin 4. The allowable DC voltage range is 12 to 30 VDC.

The GASMAX calibrated 4-20mA output signal is available at TB2 pin 3. (If an optional electrochemical sensor is also connected to the GASMAX Echem input, the Echem sensor 4-20mA output is available on TB2 pin 2).

RS-485 DIGITAL WIRING

Locate the GASMAX II alarm / MODBUS board. The board is attached to the back of the GASMAX II removable electronics assembly.

Attach the two RS-485 signal cables to TB2 pins 1 & 2. Attach the signal shield wire to TB2 pin 3. **NOTE:** RS-485 is polarity-sensitive and the wires on pins 1 & 2 may need to be swapped for proper operation. If wiring in a "daisy chain", terminals 4 & 5 are available for outgoing RS-485 wiring.

If necessary, select Jumper 1 (J1) position "A" to enable the RS-485 termination resistor. This is typically done on the device furthest from the RS-485 master controller.

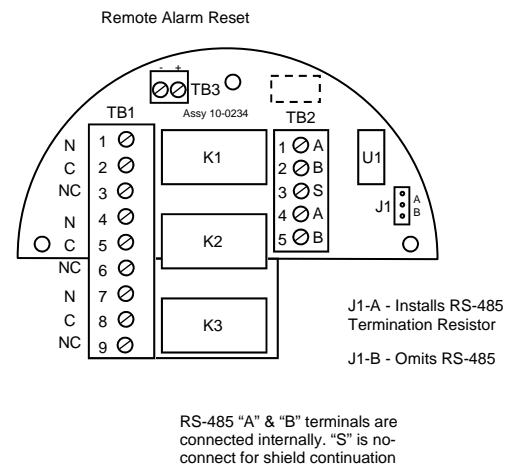

Fig 2. GASMAX Alarm / MODBUS Board

INITIAL STARTUP & CALIBRATION

Apply power to the GDS-IR / LPI and allow the instrument to stabilize for at least one (1) hour.

Attach a calibration cup to the sensor head and apply a steady flow of “zero air” to the instrument for one minute. Hold the magnetic wand over the “DN / CAL” switch on the lower left side of the display until the GASMAX enters calibration mode. Follow the on-screen instructions to calibrate the GASMAX II / SmartIR unit.

CLEANING

The SmartIR sensor is not designed for user disassembly. Contact GDS Corp for further information regarding cleaning and/or sensor replacement.

HYDORCARBON RESPONSE

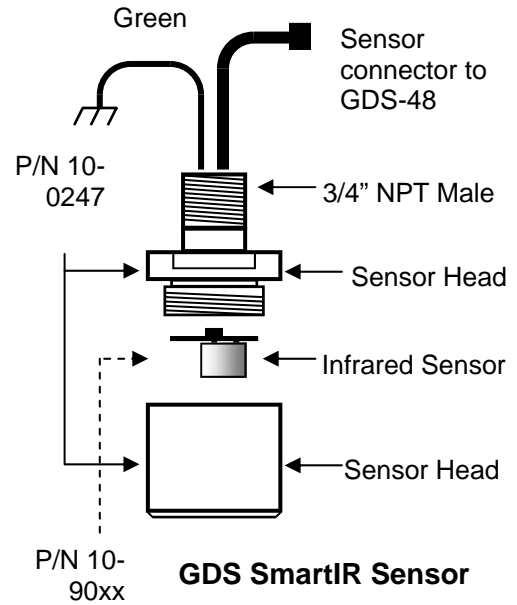
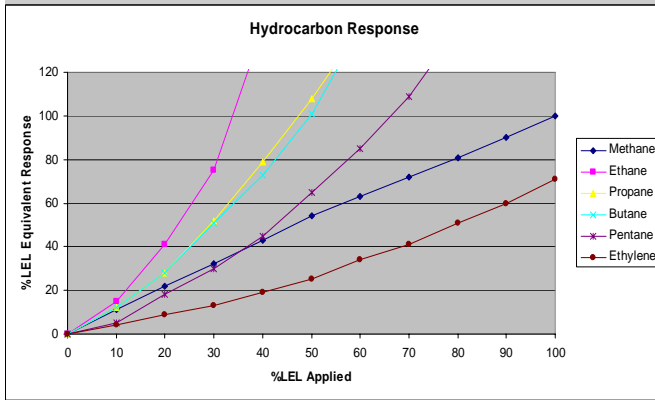

SPARE PARTS & ACCESSORIES

10-9050	Replacement SmartIR Sensor
10-0198	Sensor splash guard
10-0203	Sensor calibration cup
10-0205	Flow cell for process monitoring
10-0187	Sensor removal tool
1000-0078	Large black magnet
10-0232	Replacement display assy
10-0233	Replacement I/O power supply assy
10-0234	Replacement Alarm / MODBUS assy
10-0250	Replacement isolated 4-20mA assy

ALL DIMENSIONS IN INCHES

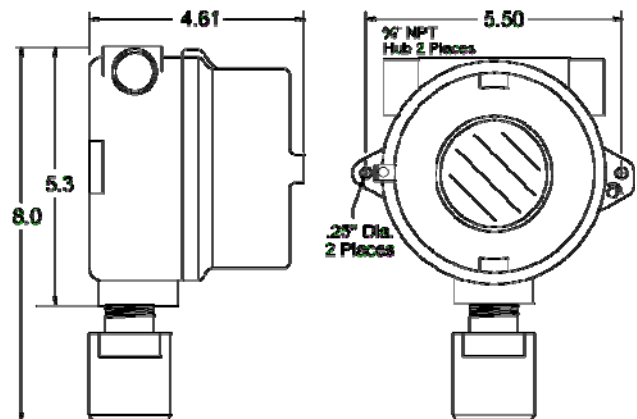

GDS Corp.

2513 Hwy 646
 Santa Fe, Texas 77510
 (409) 927-2980 (409) 927-4180 fax
 www.gdscorp.com info@gdscorp.com