

# Quickstart Guide

## GASMAX II / PID Toxic & VOC Gas Monitor



### I. MOUNTING LOCATION

**IMPORTANT - Before installing the GASMAX II, ensure there are NO toxic gases present. Declassify the area if necessary.**

Factors such as fans, prevailing winds, convection and density must be considered when determining location. As with all sensors, the GASMAX II should be protected from directed water, shock, vibration and dirt. The PID sensor should be mounted vertically.

Use installation practices approved for the appropriate area. When installed properly, the GASMAX II with PID sensor is certified for use in areas rated Class 1, Div 1, Groups B, C & D.

### II. POWER & 4-20mA OUTPUT WIRING

Unscrew the cover of the GASMAX II. Loosen the thumbscrews holding the display assembly and remove it. The power supply board is attached to the inside of the GASMAX housing (see Figure 1).

Connect +DC to TB2 pin 1 and –DC to TB2 pin 4. The allowable DC voltage range is +12 to 30 VDC. The calibrated 4-20mA LEL output signal is available at TB2 pin 3.

If an optional electrochemical sensor is connected to the GASMAX II, the 4-20mA Echem output is available on TB2 pin 2.

### III. RS-485 DIGITAL INTERFACE WIRING

If the GASMAX II Alarm / MODBUS board is installed, it will be attached to the GASMAX II electronics assembly (see Figure 2).

Attach the RS-485 wires to TB2 pins 1 & 2 and the shield wire to pin 3. RS-485 is polarity-sensitive and the wires on pins 1 & 2 may need to be swapped for proper operation. If wiring in a “daisy chain”, terminals 4 & 5 are available for outgoing RS-485 wiring.

If necessary, select Jumper 1 (J1) position “A” to enable the RS-485 termination resistor. This is typically done on the device furthest from the RS-485 master controller.

### IV. SENSOR INTERFACE WIRING

If a local PID smart sensor is installed, it will be connected to connector S1 on the GASMAX II power supply board (See Figure 1).

If a remote PID sensor is installed, it should be connected to the R, C and A terminals on the GASMAX II power supply board (See Figure 1). The remote sensor housing terminals are also labeled R, C and A for easy identification.

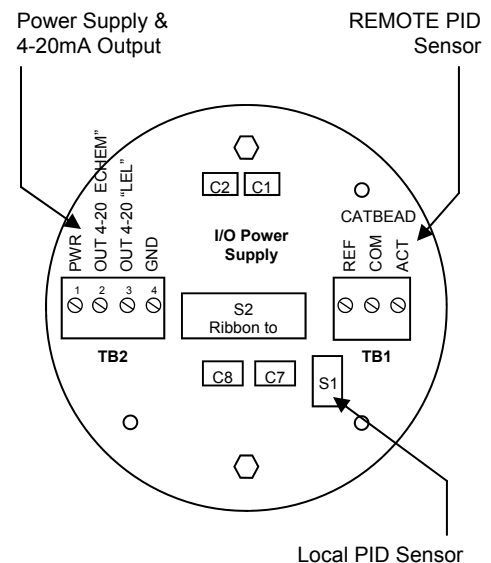

Fig 1. GASMAX Power Supply Board

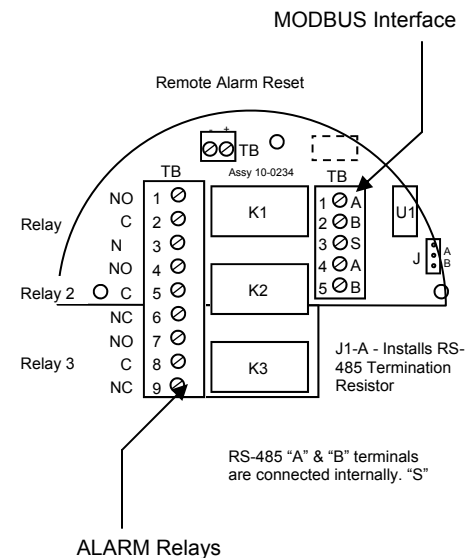

Fig 2. GASMAX Alarm / MODBUS Board

## V. LOCAL SENSOR SETUP

If a *local* PID smart sensor is installed, the GASMAX II will automatically identify the sensor type during power-up and load the configuration parameters stored in the sensor.

## VI. REMOTE SENSOR SETUP

If a remote PID sensor is installed, sensor information must be entered manually.

### ENABLE THE LEL/CURRENT CHANNEL

Press and hold the UP key for 5 seconds until the "Enter Key Sequence" menu appears. Press the UP key four times in sequence to access the XMITTER CONFIG menu. Make sure the LEL/CURRENT channel is ON. If an optional toxic sensor is also installed (two-channel mode), make sure the O2/TOXIC channel is also ON. Exit the XMITTER CONFIG menu by pressing the NEXT key.

### INITIALIZE THE GASMAX SOFTWARE

Press the EDIT key to display the Main Menu. Select the Sensor Information menu entry and press EDIT. Select INSTALL SENSOR and press EDIT to confirm. Select Cat-Bead Input Type. This step deletes any existing historical calibration data and resets sensor life to 100%. Press NEXT to exit the menu.

### SET SENSOR VOLTAGE

Press the EDIT key to display the Main Menu. Scroll down to the TECHNICIAN ONLY entry and press EDIT again. Press the UP key four times in sequence to enter the TECHNICIAN ONLY menu.

Select SET SENSOR VOLTAGE and adjust the catalytic bead excitation voltage to 5.0V as measured across the REMOTE SENSOR JUNCTION BOX TERMINAL STRIP "A" and "R" terminals.

**IMPORTANT: Do not exceed 5.5VDC across the PID sensor at any time. Excess voltage can damage the sensor and void the warranty,**

## SPARE PARTS & ACCESSORIES

|           |                                    |
|-----------|------------------------------------|
| 10-9060   | Replacement PID Sensor (0-2000ppm) |
| 10-9061   | Replacement PID Sensor (0-20ppm)   |
| 10-906XR  | Sensor Refurbishment for PID       |
| 10-0198   | Sensor splash guard                |
| 10-0203   | Sensor calibration cup             |
| 10-0205   | Flow cell for process monitoring   |
| 10-0187   | Sensor removal tool                |
| 1000-0078 | Large black magnet                 |
| 10-0232   | Replacement display                |
| 10-0233   | Replacement I/O power supply       |
| 10-0234   | Replacement Alarm / MODBUS         |
| 10-0250   | Replacement isolated 4-20mA        |

Press NEXT to exit the TECHNICIAN ONLY menu (or any menu).

**For maximum accuracy, allow the sensor to warm up for 24 hours BEFORE setting the balance and preamp gain.**

### SET BALANCE

Attach a calibration cup to the sensor head and apply "zero gas" to the sensor and wait one minute for the reading to stabilize. Enter the TECHNICIAN ONLY menu and select the SET BALANCE option. Adjust the sensor output for a coarse zero. If the sensor is working properly, the reading prior to setting zero should be +/- 3% LEL.

### PREAMP GAIN SET

Apply a specified "span gas" to the sensor and allow the GASMAX reading to stabilize (~ 60 seconds). Using the PreAmp Gain Set option, adjust the reading to a value within 5% of the span gas value (coarse adjustment only). Press NEXT to exit the menu.

## VII. CALIBRATION

Calibration should be performed at least once every three months for PID sensors. In some cases, more frequent calibration may be required due to environmental considerations.

Attach a calibration cup to the sensor head and apply a steady flow of "zero air" to the instrument for one minute. Hold the magnetic wand over the "DN / CAL" switch on the lower left side of the display until the GASMAX enters calibration mode. Follow the on-screen instructions to calibrate the GASMAX II unit.

ALL DIMENSIONS IN INCHES

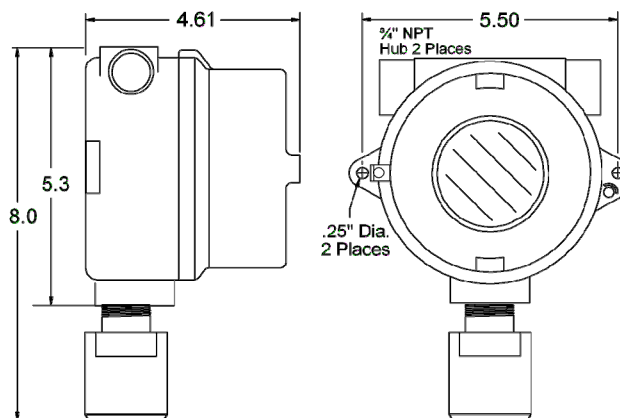

### GDS Corp.

2513 Hwy 646  
Santa Fe, Texas 77510  
(409) 927-2980 (409) 927-4180 fax  
www.gdscorp.com info@gdscorp.com