

## SD125N-2 Weather-proof & Heavy Duty Loudspeaker SD125N-2 Series

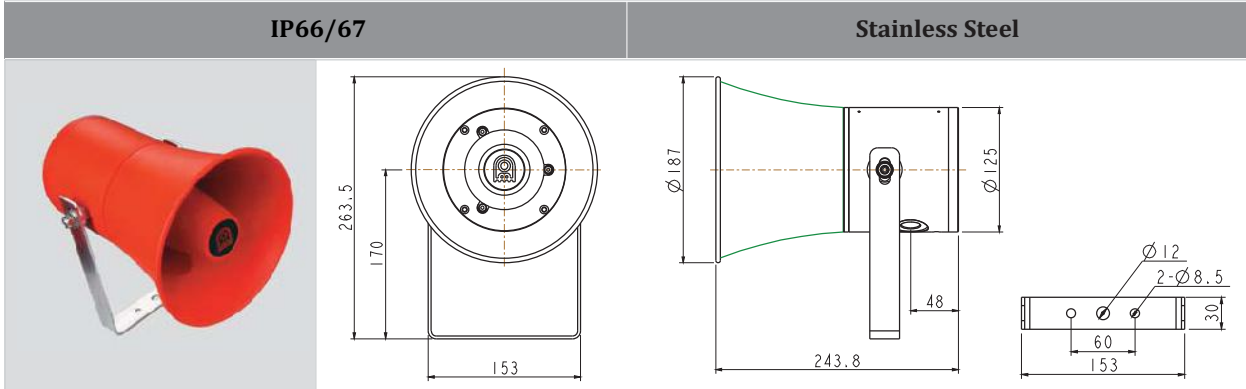

### Specification

Ambient Temperature:	-40 to +70° C
Humidity:	Up to 95% RH
Ingress Protection:	IP66/67
Enclosure Material:	Stainless Steel
Bracket Material:	Stainless Steel
Enclosure Colour:	Black, Blue, Yellow, Red or Others (Selectable)
Weight:	6.2 Kg
Dimension:	L243*dia.187.54 (mm)
Max Power:	15W, 25W
Max/Rated Power:	15W/ 15 -7.5 -4 -2 -1 -0.5W; 25W/ 25 -12.5 -6 -4 -2 -1W 30W/30- 20- 15- 10- 5- 2.5W; 50W/ 50- 40- 30- 20- 15- 7.5W
Sound Output:	Up to 123dB
Effective Frequency Range:	300Hz to 8kHz
Opening Angle 1kHz /4kHz (-6 dB):	160° / 50°
Rated Voltage:	100 V
Rated Impedance:	960ohm(15W); 576ohm(25W); 480ohm (30W); 288ohm 950W)
Terminals:	Accept up to 2.5mm <sup>2</sup> Cable
Cable Entry:	2* M20, M25, 1/2" NPT, 3/4"NPT or Others
Electromagnetic:	CE <sub>0470</sub> Marked

### Ordering Code

Products	Max Power	Duty Label*	Tag Label*	Entry Size	Cable Entry Position	Finish Color
SD125N-2	15- 15W	N-No	N-No	A- M20	L-Left Side	R-Red
	25- 25W	Y-Yes (Specify Word- ing)	Y-Yes (Specify Word- ing)	B- M25	R-Right Side	B-Blue
	30- 30W			C-1/2" NPT		BL-Black
	50- 50W			D-3/4" NPT		O-Others (Specify)
	O-Other					

i.e. SD125N225NNALRR

<b>SD125N-2</b>	<b>25</b>	<b>N</b>	<b>N</b>	<b>A</b>	<b>LR</b>	<b>R</b>
Product	25W	No Duty Lable	No Tag Label	M20 Cable Entry	Lefe& Right Sides	Red Finish

\*These" \* " accessories need to be ordered seperately. Please refer to product datasheet for your information.