

Quickstart Guide

GDS-49 Stand-alone Sensor Transmitter



Installation Instructions for GDS-49 Sensor Transmitter

The GDS-49 is a stand-alone sensor transmitter designed to enable highly sensitive electrochemical (EC) gas sensors to operate reliably when located hundreds or thousands of feet from receiver electronics. The GDS-49 does this by converting the sensor output voltage into an industry standard 4-20mA current output signal.

1) Install the GDS-49 in desired location. The GDS-49 allows an additional 500 ohms loop impedance when using a nominal 24VDC power supply. It is highly recommended that the GDS-49 be installed **pointing downwards** to minimize water intake. If splashing water is a concern, an optional Splash Guard (p/n #10-0198) is available.

2) Connect to field wiring as shown. The GDS-49 output is **non-polarized** and will work properly no matter which WHITE wire is connected to the PLUS side of the loop. If installing as **Intrinsically Safe**, special precautions are necessary. See dwg# 11-0100 on back of this guide for more information.

3) Allow the GDS-49 to operate for 24 hours before the initial calibration. If it can be verified that the ambient air is free of target gas, atmospheric air may be used for ZERO calibration. If not, use a cylinder of ZERO AIR. For SPAN calibration, connect a cylinder of SPAN GAS (approximately 50-75% of sensor full scale reading) and perform a SPAN calibration. The length of time between SPAN calibration cycles will be determined by sensor location and environmental conditions.

4) To replace the electrochemical sensor, use the Sensor Replacement Tool (p/n #10-0187) to remove the GDS-49 cover and unplug / replace the sensor element.

IMPORTANT: All electrochemical sensors require periodic calibration with a reference span gas sample to ensure continued accuracy and safety. The GDS-49 output signal **must** be conditioned with a controller or monitor device capable of ZERO / SPAN calibration such as the GDS Corp. C1 or C2 *Protector* Controllers or the GASMAX II Gas Monitor. Failure to periodically calibrate this device will result in degraded accuracy.

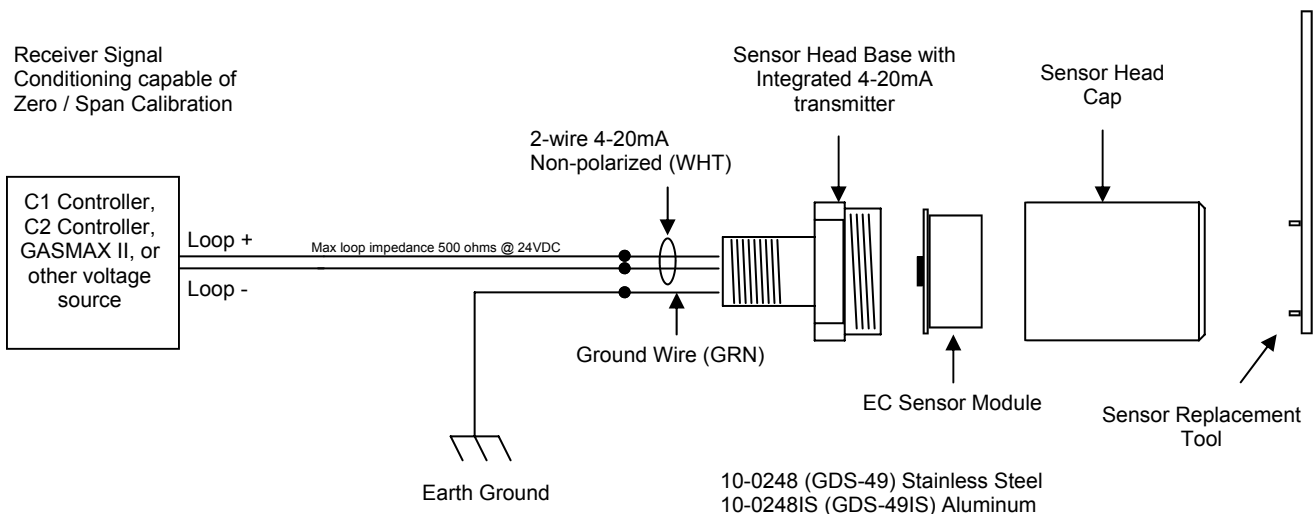

Hazardous Area
CLASS 1, GROUP A,B,C AND D;

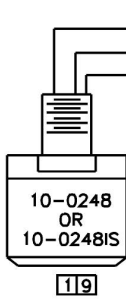

LOOP+ 7
LOOP- 7

Safe Area

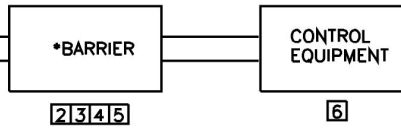

* Barriers only required for Intrinsically Safe installations.

Hazardous Area
CLASS 1, GROUP A,B,C AND D;

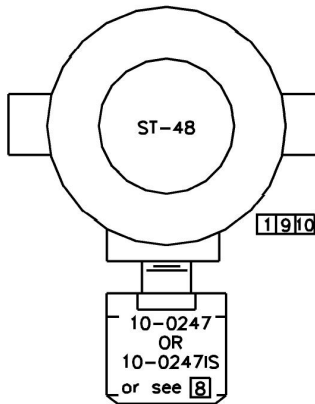

LOOP+ 7
LOOP- 7

Safe Area

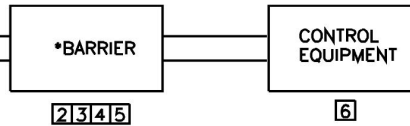

- 10 A conduit seal within 18 inches of the enclosure is not required for Intrinsically Safe installations.
- 9 Warning: Substitution of components may impair intrinsic safety.
- 8 The ST-48 may be fitted with any CSA certified compatible XP toxic sensor head. The hazardous location installation is limited to an area governed by the lowest group rating of the assembly's parts.
- 7 Intrinsically safe wiring. Important: Only ST-48 two wire models may be applied in intrinsically safe installations.
- 6 Control equipment must not use or generate more than 250 V with respect to earth.
- 5 Barriers must be installed in accordance with barrier manufacture's control drawing and artical of the National Electrical Code ANSI/NFPA 70, CEC Part 1 or other local installation codes, as applical.
- 4 Selected barriers must be third party approved as intrinsically safe for the application and have Vcc not exceeding Vmax and Isc not exceeding Imax of the intrinsically safe equipment, as shown in Table 1.

Table 1:

I.S. Equipment	Barrier
Vmax	> Voc
Imax	> Isc
Ci + Ccable	≤ Ca
Li + Lcable	≤ La

- 3 Cable capacitance plus intrinsically safe equipment capacitance must be less than the marked capacitance (Ca) shown on any barrier. The same applies for inductance. Capacitance and inductance of field wiring from the intrinsically safe equipment to the barrier should be calculated as (Ccable = 60pF/ft and Lcable = 0.2 uH/ft) and should be included in system calculations.
- 2 Barrier may be in Division 2 location if so approved.
- 1 Entity parameters:

Vmax = 30 Vdc
Imax = 100 mA
Ci = 0
Li = 0

ARC SYSTEMS

ST-48, 10-0248, 10-0248IS
INSTALLATION DRAWING

dwg by: TWL opp by: [blank] date: 06.30.05
scale: NONE drawing: 11-0100
sz: A lfile: 1101000E.DWG sheet: 1 of 1

REVISIONS:

Rev	Description	Appr	Date
A	ADDED NOTE 8		082205
B	CHANGED NOTE 7		091405
C	REVISED TITLE BLOCK		091605
D	ADDED NOTE 9		091905
E	ADDED NOTE 10		091905