



Macurco™ Combustible Gas Detector

GD-6



Detector, Controller and Transducer



Methane, Propane or Hydrogen Gas Detection

The GD-6 is a versatile, easy-to-use device that allows you to select between methane, propane, or hydrogen gas detection. It provides low-level detection of combustible gas in an easy-to-maintain monitor that is factory calibrated for simple installation. This low voltage detector provides automatic feedback and fan control that can help reduce combustible gas concentrations in parking garages, battery rooms, maintenance facilities, and other locations that require combustible gas detection.

Selectable options include:

- Measurement: Methane (NG), Propane (LP) or Hydrogen (H₂)
- Output: Fan relay, Alarm relay and 4-20mA current loop
- Controls: Digital display (0-50% LEL), buzzer, fan delay, fan minimum runtime

Installation

- Mounts on a standard 4" x 4" electrical box
- 5 A SPDT fan relay controls valves, louvers or exhaust fans
- 0.5 A N.O. or N.C alarm relay connects to warning devices or control panels
- 4-20mA current loop - compatible with the Macurco DVP-120 Control Panel
- Factory calibrated

Other Features

- Supervised system design: detector problem will cause the fan & alarm relay to activate
- Optional calibration kit allows the GD-6 to be field tested and calibrated
- ETL Listed to UL 61010-1



GD-6 Specifications

- Power: 3 W (max) from 12 to 24 VAC or 12 to 32 VDC
- Current @ 24 VDC: 75 mA in alarm, 50 mA fan relay on and 23 mA stand by
- Shipping Weight: 1 pound (0.45 kg)
- Size: 4 1/2 x 4 x 2 1/8 in. (11.4 X 10.2 X 5.4 cm)
- Color: Dark gray
- Connections: plugs/terminals
- Mounting box: (not included) 4x4 electric
- Fan relay: 5 A, 240 VAC, pilot duty, SPDT
- Fan relay actuation: selectable at 1, 2, 3, 4, 5, 6, 7, 8, 9, 10 (default), 11, 12, 13, 14, 15, 16, 17, 18, 19, 20% LEL
- Fan Delay Settings of 0, 1, 3 (default), 5 and 10 minutes
- Fan Minimum Runtime settings are OFF (default), 3, 5, 10 or 15 minutes
- Alarm relay: 0.5A 120 V, 60 VA
- Alarm relay actuation: selectable N.O. default or N.C.
- Alarm relay settings: OFF, 5, 10, 15, 20 (default), 25% LEL
- Current Loop, 4-20 mA for 0-50% LEL
- Operating Environ: 0°F to 125° F (-18°C or above 52°C).10 to 90% RH

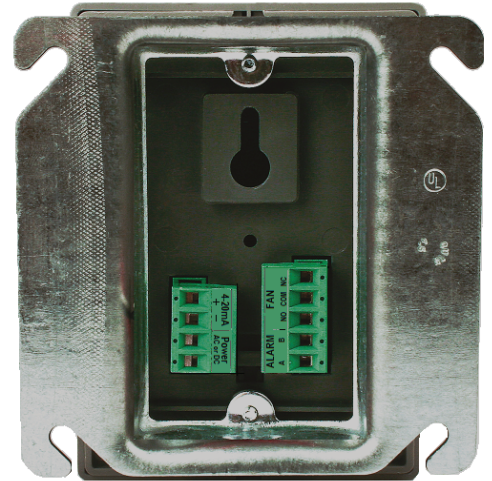

GD-6 Rear View

Location

A GD-6 is usually located in areas where there is potential for gas leaks; where there are gas appliances, areas through which gas pipes pass, where batteries are being stored or charged, etc. DO NOT mount the GD-6 in a corner. DO NOT mount the GD-6 where the normal ambient temperature is below below 0°F or exceeds 125°F (-18°C or above 52°C). If the target gas is lighter than air; natural gas (Methane) or Hydrogen (H₂), mount the GD-6 high on a wall or column about one foot down from the ceiling. If the target gas is heavier than air; propane (LP), mount the GD-6 low on a wall or column one foot above the floor. Use the same spacing as for smoke detectors, 30 foot centers, 900 square feet per detector.

TYPICAL CONNECTION OF GD-6

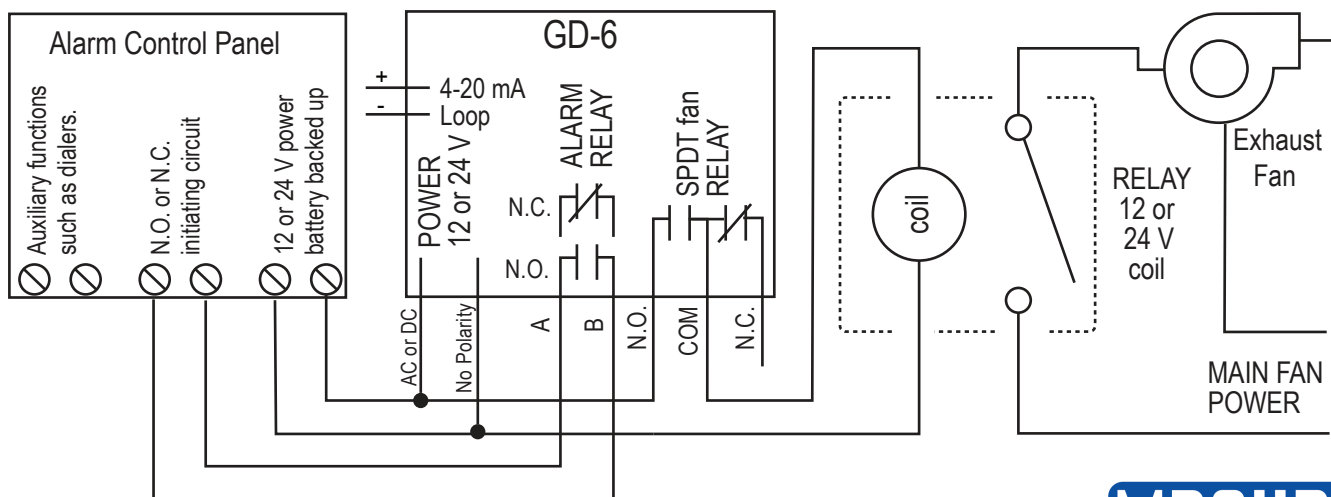

TYPICAL COVERAGE 900 SQUARE FEET

Made in the U.S.A. with US and imported materials

© Aerionics 2012. All rights reserved.
Macurco is a trademark of Aerionics, Inc.

AUTHORIZED DISTRIBUTOR:

GasDetectorsUSA.com

Houston, Texas USA

sales@GasDetectorsUSA.com

832-615-3588



Gas Detection Experts