



SS103-3A SS103-10A

AUTOMATIC EXHAUST FAN CONTROLLERS FOR PARKING GARAGES

Building codes require that enclosed parking garages either have exhaust fans operate continuously, or have automatic Carbon Monoxide (CO) detection and exhaust fan control systems. The difference in fan operating time is 24 hours a day versus one to two hours. Energy savings are significant.

The SS103-3A and SS103-10A are exhaust fan controllers which, in conjunction with CS102A, SS102H or SS102HC-1 Carbon Monoxide detectors, provide automatic controls to ensure a safe environment in parking garages or maintenance facilities. The SS103-3A can control up to three of the 102 type CO detectors, while the SS103-10A can control up to 10 of the 102 type CO detectors. (The CS102A replaced the SS102H in mid 2000).

The SS102/103 systems are designed to meet all known specifications for safety in enclosed parking garages, including the Uniform Building Code and OSHA 50 ppm CO requirements.

- ◆ MONEY saving devices, both in energy costs and extended fan life.
- ◆ Units are enclosed in sturdy electrical boxes, rain proof or oil tight.
- ◆ Clearly labeled terminal strips for easy hook up.
- ◆ Fan settings are end user adjustable, to meet any specification.
- ◆ Alarm circuits provided with adjustable delay of turn on time.
- ◆ Bright LEDs indicate system status.
- ◆ LEDs indicate which sensors are active, and supervise wiring.
- ◆ SS103-3A and SS103-10A are approved by the Los Angeles Dept. of Bldg. & Safety.
- ◆ All SS102 Sensors are supervised; controllers indicate status.
- ◆ Alarm circuits warn of a high CO level, such as 200 PPM UBC STEL.
- ◆ No regular maintenance necessary.
- ◆ Simple installation and operation.

SS103-3A



8 x 6 x 4
7
2 amps
3
10
240
25 to 115
25 to 175
#2 delayed
30 sec.
3 to 33
15

SPECIFICATIONS

SIZE: INCHES	12 x 10 x 6
WEIGHT: POUNDS	15
POWER INPUT 120 VAC	2 amps
OUTPUT CONTROL RELAYS	3
RELAY RATING: AMPS	10
RELAY RATING: VOLTS	240
FAN 1 RANGE, PPM	25 to 175
FAN 2 RANGE PPM	75 to 225
ALARM RANGE, PPM	100 to 400
FAN TURN ON DELAY	2 min.
ALARM DELAY, MIN.	¼ to 60
RELAY TURN OFF DELAY, SEC.	1

SS103-10A



Manufactured By:

Macurco
3946 S. Mariposa Street
Englewood, Colorado, USA 80110
303-781-4062 F: 303-761-6640
www.macurco.com

Distributed By:

ENGINEER AND ARCHITECT SPECIFICATIONS

Carbon Monoxide detection and exhaust fan control shall be provided by a Macurco SS103 and CS102A or SS102HC-1 system. This System shall use CS102A or SS102HC-1 carbon monoxide (CO) to voltage transducers that measure the level of CO and provide this information to the SS103 in an analog mode: voltage. The CO to voltage transducers (CS102A) and (SS102HC-1) shall mount in standard electrical boxes (4S) and operate on low voltage.

All power for the CS102A or SS102HC-1 transducers shall be provided, via unshielded four conductor cable, from the SS103 control panel. This SS103 control panel shall provide three levels of fan or alarm control relays. These relays (N.O.) shall be for pilot duty only and capable of switching 10 A loads up to 240 VAC.

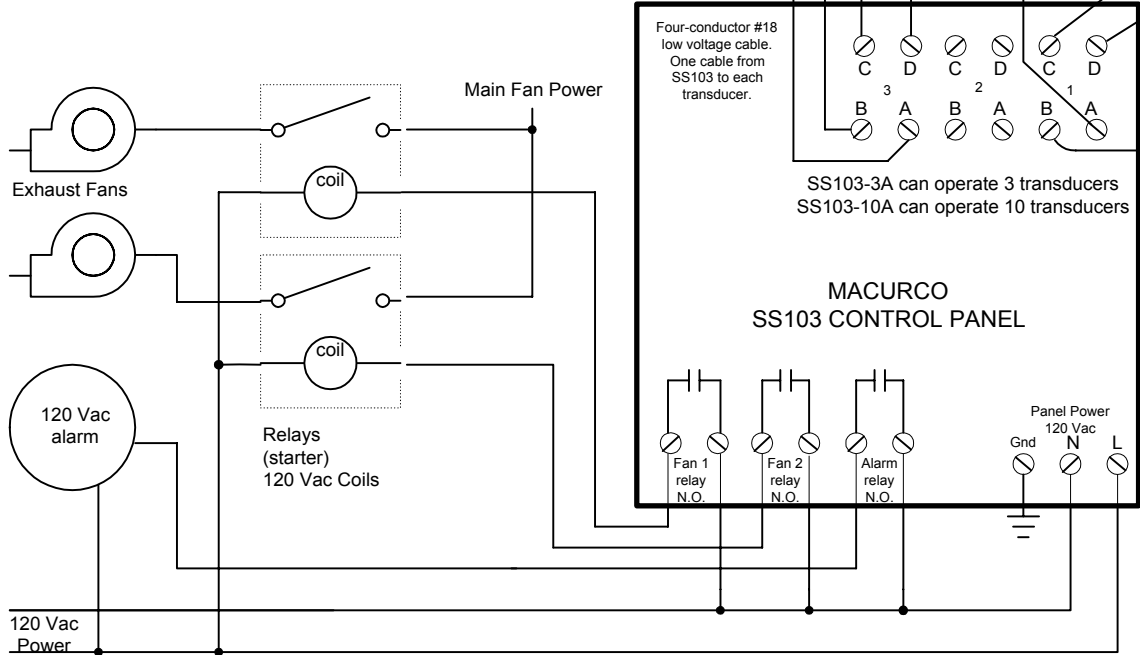

NOTE:

1. Connect only one transducer per zone on the control panel.
2. C and D terminals are power. A is the plus input. B is the common input.

NOTES:

1. Typical coverage for a CS102A or SS102HC-1 transducer is 5000 square feet. Extra transducers may be needed near areas where people work, such as toll booths. Mount transducers where people breathe; on walls or columns about 5 feet above floor.
2. Macurco provides only the SS103 control panels and CS102A and SS102HC-1 transducers. Fans, relays, horns, and other devices are not provided by Macurco and are strongly recommended to be tested and verified for proper operation before permanent installation.
3. See the appropriate building code for the size of fans and air changes per unit of time.

