

DVP-120 Installation & Operating Instructions

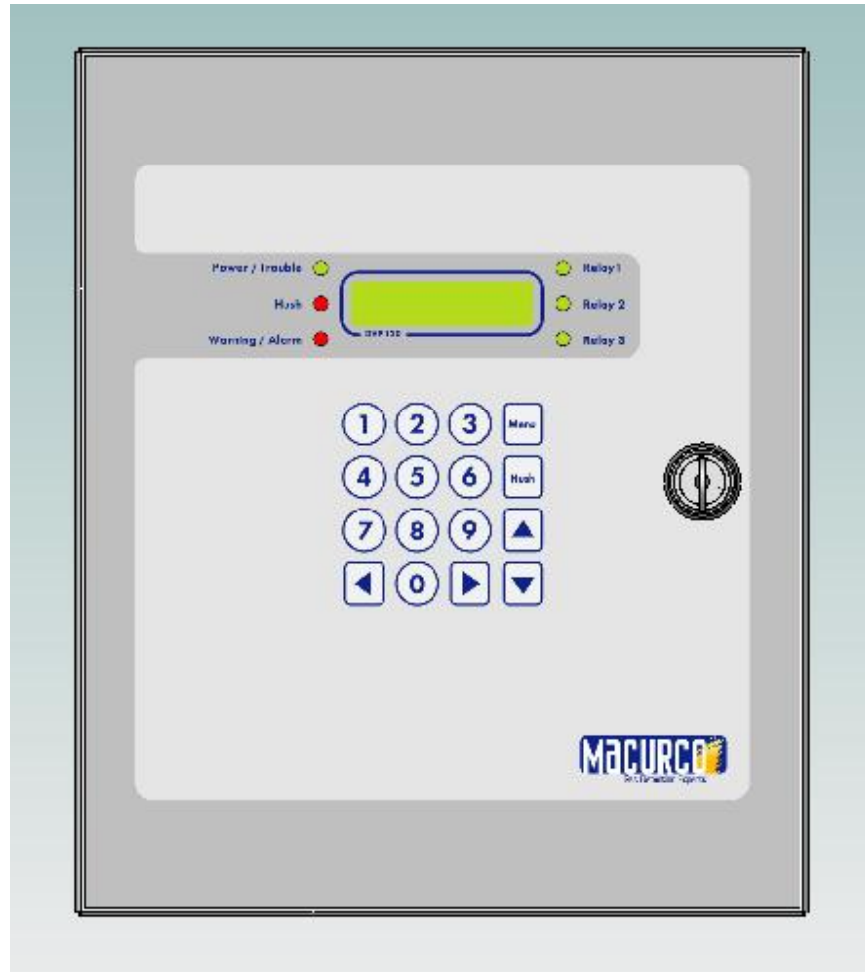

TABLE OF CONTENTS

1	INTRODUCTION	5
1.1	General Information	5
1.2	Features	5
1.3	Compatible Macurco Transducers.....	5
1.4	Specifications	8
1.5	Warranty.....	8
1.6	Return Instructions	8
2	Installation & Connection.....	9
2.1	Mounting the DVP-120.....	9
2.2	General Wiring Information.....	9
2.3	Main power Connection	10
2.4	Remote Sensor Connection	10
2.5	Relay Connection	12
2.6	Horn & Strobe Connection.....	13
2.7	Interfacing Macurco Sensors.....	14
3	Operation	15
3.1	Initial Operating Mode.....	15
3.1.1	Status Light Display	15
3.1.2	User Interface	16
3.1.3	Normal Status Display.....	17
3.1.4	ALARM Status Display.....	17
3.1.5	Warning Status Display.....	18
3.1.6	Trouble Status Display	18
3.2	Ventilation control.....	19
3.2.1	Zone Signal Display	19
3.3	Setting the System Configuration.....	20
3.3.1	System Menu	21
3.3.2	Configure System Submenu	21
3.3.3	Configure Sensors Submenu.....	24
3.3.4	Configure Relays, Horn & Strobe Submenu.....	26
3.3.5	Configure Horn Submenu.....	27
3.3.6	Configure Strobe Submenu.....	28
3.3.7	Configure Zones Submenu	29
3.3.8	Configure Signals Submenu	33
4	Troubleshooting	37
4.1	System Status Light Flashing	37
4.1.1	Input Channel Trouble.....	37
4.1.2	Internal Controller Board Trouble	37
4.2	Timed ventilation problem	37
4.3	No Power.....	38
4.4	LCD Display unreadable	38
4.5	The Keypad does not respond (LCD shows KEYS LOCKED)	38
4.6	The Keypad does not respond after silencing an Alarm, Warning or Trouble.	38
4.7	After a power failure	39
4.8	Appendix A – Quick Set-up	40

LIST OF FIGURES

Figure 1-1	System Wiring Diagram	6
Figure 1-2	DVP-120 Internal View	7
Figure 2-1	Sensor Interface Connector.....	10
Figure 2-2	Relay Connector	12
Figure 2-3	Horn & Strobe Connector	13
Figure 3-1	Model Display	15
Figure 3-2	Warm-Up display.....	15
Figure 3-3	Keypad layout.....	16
Figure 3-4	Normal System Display.....	17

Figure 3-5 Sensor prompt.....	17
Figure 3-6 Alarm display.....	17
Figure 3-7 Alarm Silenced message.....	18
Figure 3-8 Warning display.....	18
Figure 3-9 Warning Silenced message.....	18
Figure 3-10 Trouble display.....	18
Figure 3-11 Trouble Silenced message.....	19
Figure 3-12 Zone Signal display.....	19
Figure 3-13 Zone Signal Silenced message.....	19
Figure 3-14 Hardware Summary.....	20
Figure 3-15 Save Configuration? Prompt.....	20
Figure 3-16 Set Time of Day.....	21
Figure 3-17 Enter Hours.....	21
Figure 3-18 Enter Minutes.....	21
Figure 3-19 Set Day of the week.....	22
Figure 3-20 Load Default Configuration.....	22
Figure 3-21 Change Password.....	23
Figure 3-22 Enter Password.....	23
Figure 3-23 Password Prompt.....	23
Figure 3-24 Wrong Password Prompt.....	23
Figure 3-25 Sensor Summary.....	24
Figure 3-26 Sensor Type.....	24
Figure 3-27 Sensor's Alarm Level.....	24
Figure 3-28 Sensor's Warning Level.....	25
Figure 3-29 Sensor's Range.....	25
Figure 3-30 Relay Summary.....	26
Figure 3-31 Relay Mode.....	26
Figure 3-32 Turn On Delay.....	26
Figure 3-33 Minimum on time.....	26
Figure 3-34 Horn Summary.....	27
Figure 3-35 Horn Mode.....	27
Figure 3-36 Horn Turn On Delay.....	27
Figure 3-37 Horn Minimum on time.....	27
Figure 3-38 Strobe Summary.....	28
Figure 3-39 Strobe Mode.....	28
Figure 3-40 Strobe Turn On Delay.....	28
Figure 3-41 Strobe Minimum on time.....	28
Figure 3-42 Zone Controls.....	29
Figure 3-43 Zone Group Type.....	30
Figure 3-44 Timer Days Selection.....	30
Figure 3-45 Start Time Selection.....	30
Figure 3-46 Stop Time Selection.....	30
Figure 3-47 Sensor Selection.....	31
Figure 3-48 Add/Remove sensor prompt.....	31
Figure 3-49 Rising Trip Point Entry.....	31
Figure 3-50 Falling Trip Point Entry.....	31
Figure 3-51 Sensor Mode Selection.....	32
Figure 3-52 Quorum Entry.....	32
Figure 3-53 Alarm Signals.....	33
Figure 3-54 Buzzer Alarm Signal.....	33
Figure 3-55 Horn Alarm Signal.....	33
Figure 3-56 Strobe Alarm Signal.....	34
Figure 3-57 Warning Signals.....	34
Figure 3-58 Buzzer Warning Signal.....	34
Figure 3-59 Horn Warning Signal.....	34
Figure 3-60 Strobe Warning Signal.....	35
Figure 3-61 Trouble Signals.....	35
Figure 3-62 Buzzer Trouble Signal.....	35
Figure 3-63 Horn Trouble Signal.....	35
Figure 3-64 Strobe Trouble Signal.....	36

LIST OF TABLES

Table 2-1 Main Power Connections	10
Table 2-2 Recommended Wire Gauge	10
Table 2-3 Connector to Sensor Channel Mapping.....	11
Table 2-4 Sensor Connectors: Channel and Pin Assignments.....	11
Table 2-5 Relay Interface Signals and Connector Assignments.....	12
Table 2-6 Horn & Strobe signals and Connector Assignments	13
Table 2-7 Wire gauge for Horn & Strobe functions	13
Table 2-8 Macurco Transducers	14

1 INTRODUCTION

1.1 General Information

The DVP-120 Gas Detection and Ventilation Control Panel is a microcomputer based control panel used to operate ventilation fans based on the inputs from remotely mounted gas transducers. The unit is fully tested prior to leaving the factory, and is ready for operation after the wiring is complete and the user system configuration is entered.

System wiring includes the main power connection for the DVP-120, current loop and power connections between the remote sensors and the DVP-120, the fan control connections and/or alarm connections from the DVP-120 to the building ventilation and automation systems. Refer to Figure 1-1 for a representative system-wiring diagram.

The system configuration is entered by the user through the LCD display and keypad. Refer to Figure 1-2 for equipment locations. The system display provides the user with the system status, and the status of each configured sensor. In addition, all control functions of the DVP-120 may be accessed through the system display and keypad.

1.2 Features

- Twelve analog (current loop) input channels
- Three 16A, 240 VAC SPDT fan/alarm relays
- Drivers for external Horn and Strobe
- Externally visible system, alarm and relay status indicators
- Externally visible LCD display showing the status of each transducer and relay
- External keypad for user selection of the transducer/alarm display and setting the configuration (password protected)
- Up to three ventilation control zones can be defined
- Each zone can be controlled based on transducer signals and/or time of day
- Each relay is configurable for delay before activation and minimum on time
- Fail safe operation can be implemented
- Lockable Nema 1 type enclosure
- Modular input and output connectors

1.3 Compatible Macurco Transducers

Carbon Monoxide (CO):

- CM-2B – Solid State sensor with local concentration display (ppm)
- CM-3 – Electrochemical sensor with local concentration display (ppm)

Nitrogen Dioxide (NO):

- ND-2 – Electrochemical sensor with local concentration display (ppm)

Combustible Gasses (EX):

- GT-11A – Solid State Sensor

ENGINEER AND ARCHITECT SPECIFICATIONS

Gas detection and exhaust fan control is provided by a Macurco DVP-120 system. This System will use CM-2B or CM-3 Carbon Monoxide (CO) to current transducers, ND-2 Nitrogen Dioxide to current transducers or GT-11A Combustible Gas to current transducers. Each transducer will measure the level of the target gas and provide this information to the DVP-120 over a 4-to-20 mA current loop. The Transducers are mounted in a standard 6" x 6" electrical enclosure, and operate on low voltage (24 VDC).

All power and signal connections for the transducers are provided from the DVP-120 control panel, via unshielded four conductor cable. The DVP-120 control panel provides three relays which can be used for ventilation fan control or alarm signalling. These relays (SPDT - Form C) are for pilot duty only, capable of switching 10 amp loads up to 240 VAC.

Type 1 Enclosure

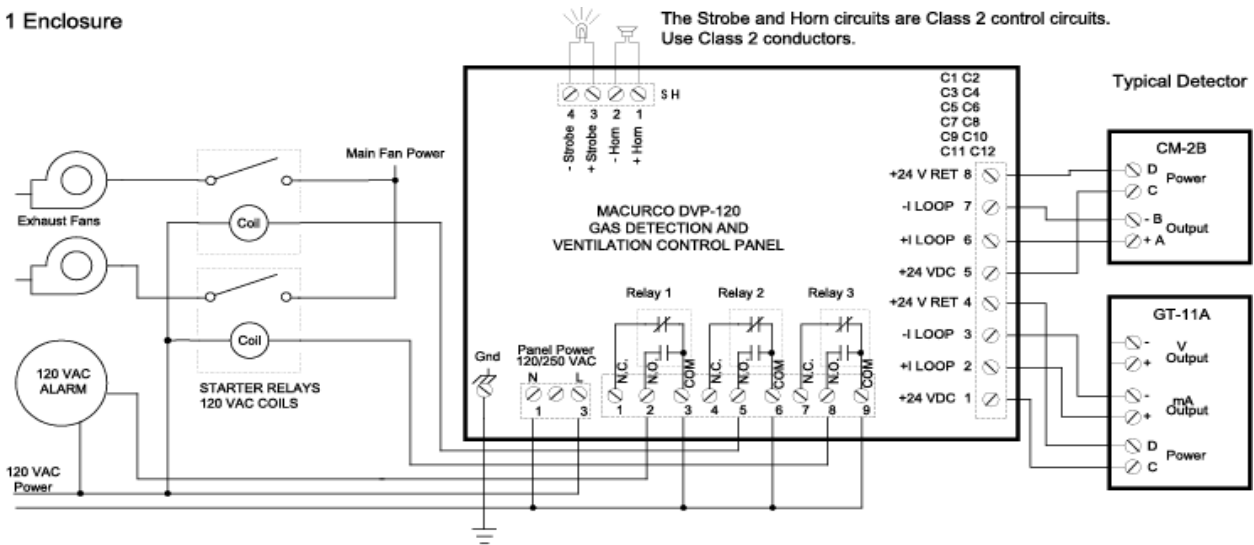

Power Circuit: Field Wiring 60 °C.

All Circuits: Use Copper Conductors Only.

Torque: Torque all field wiring terminal screws to 3.5 lbs-in.

NOTE

1. Typical coverage for a CO sensor is 5000 sq. ft., 900 sq. ft. for combustible gasses. Extra sensors may be needed near areas where people work, such as toll booths.
2. Macurco provides only the control panels and sensors. Fans, relays, and other devices are provided by the contractor.
3. See the appropriate building code for the size of fans and air changes per unit of time.

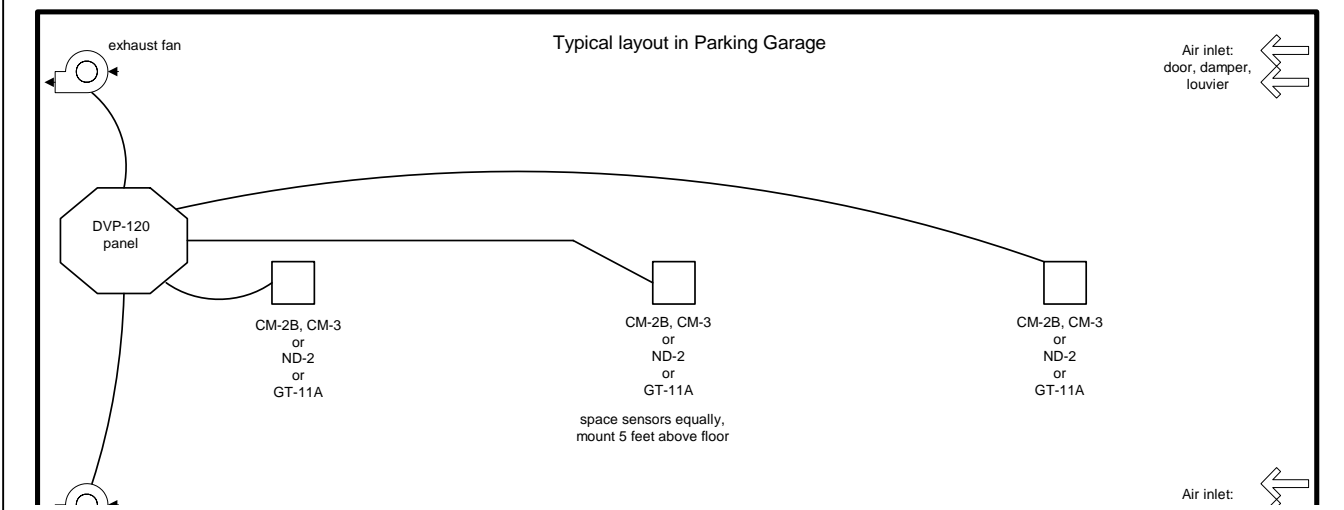

Figure 1-1 System Wiring Diagram

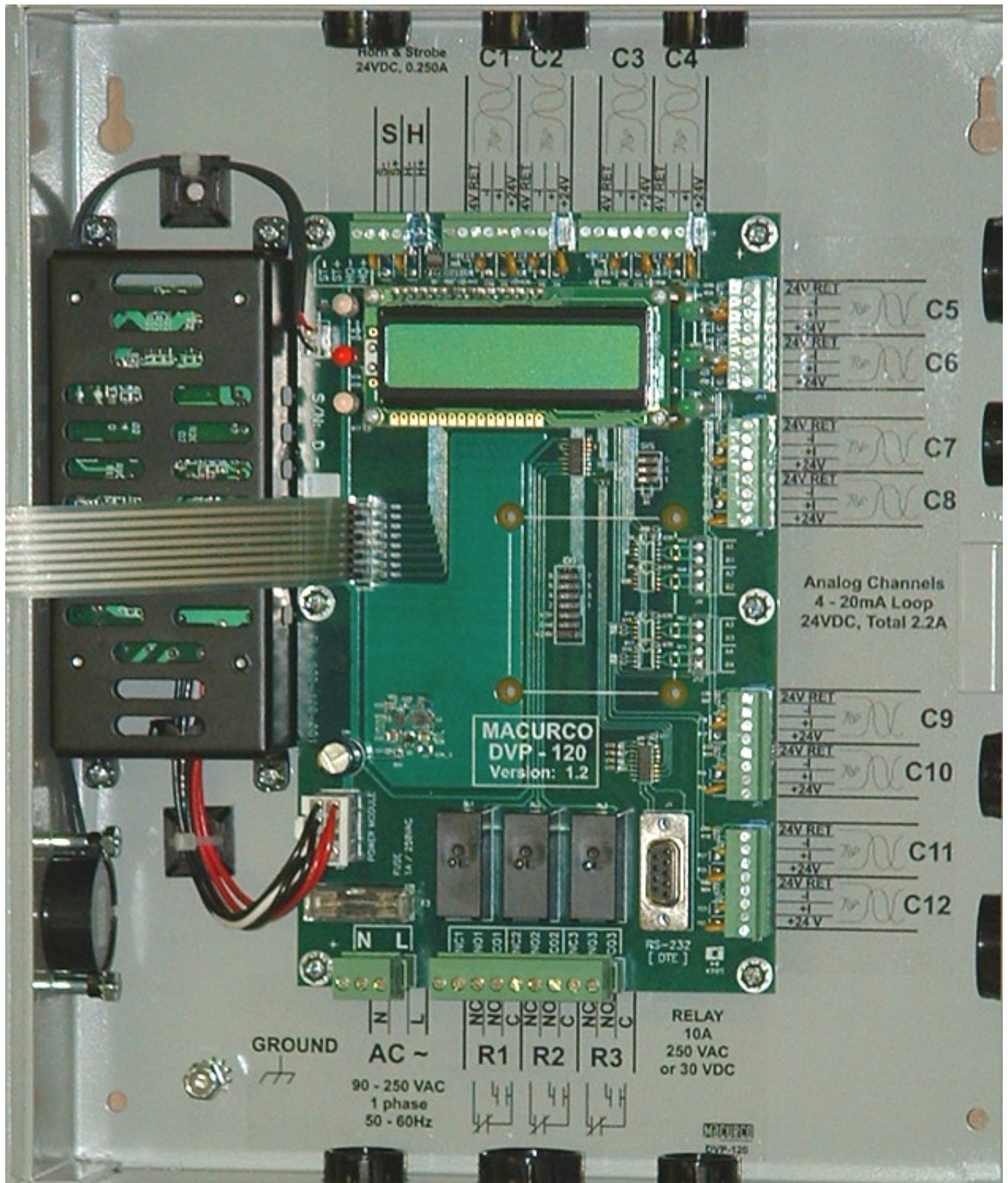

Figure 1-2 DVP-120 Internal View

1.4 Specifications¹

– Size:	10” x 12” x 2” (254 mm x 305 mm x 51 mm)
– Weight:	6 ½ lb (2.9 kg)
– Enclosure:	Nema 1 equivalent steel
– Operating Temperature:	-32 to 122 °F (0° to 50 °C)
– Operating Humidity:	0% to 95% RH non-condensing
– Power Input:	90 – 250 VAC, 1 Amp, 47 – 63 Hz, single phase
– Relay Rating (3):	SPDT, 120/240 VAC, 10 A resistive
– LCD Display:	2 rows of 16 characters with backlight
– Status Indicators (LED):	Power, ALARM/warning, Hush, Relay 1, Relay 2 & Relay 3
– Audible indicator:	Internal buzzer, 90 dbA at 1ft
– External Drivers (2):	24VDC, maximum 250 mA
– CO Transducer Range:	0 – 250PPM
– NO Transducer Range:	0 – 9.0 PPM
– EX Transducer Range:	0 – 10,000 PPM
– Relay On Delay:	0 – 15 minutes in 1 second increments
– Relay Off Delay:	0 – 15 minutes in 1 second increments

1.5 Warranty

The DVP-120 Gas Detection and Ventilation Control Panel is warranted to be free from defective material and workmanship for a period of two (2) years from the date of shipment. If any component becomes defective during the warranty period, it will be replaced or repaired free of charge, if the unit is returned in accordance with the instructions below. This warranty does not apply to units that have been altered or had repair attempted, or that have been subjected to abuse, accidental or otherwise. The above warranty is in lieu of all other express warranties, obligations, or liabilities.

THE IMPLIED WARRANTIES OF MERCHANTABILITY AND FITNESS FOR PARTICULAR PURPOSE ARE LIMITED TO A PERIOD OF TWO (2) YEARS FROM THE PURCHASE DATE.

Macurco shall not be liable for any incidental or consequential damages for breach of this or any other warranty express or implied, arising out of or related to the use of the control panel. Manufacturer or its agent’s liability shall be limited to replacement or repair as set forth above. Buyer’s sole and exclusive remedies are return of the goods and repayment of the price, or repair and replacement of non-conforming goods or parts. (The Uniform Commercial Code applicable in the State of Colorado shall govern)

1.6 Return Instructions

Call (303) 781-4062 for a Return Authorization form. Then carefully pack the control panel with a written description of the nature of the return. Send the unit to the following address:

Aerion Technologies Inc.
6555 S. Kenton St., Ste 304
Centennial, CO
USA 80111

¹ Macurco reserves the right to modify or change the specifications of all products without prior notification to the user.

2 Installation & Connection

2.1 Mounting the DVP-120

Mounting holes are provided in the DVP-120 case at the four corners. The top two are keyhole shaped so that the panel can be hung and then the two bottom screws driven to hold the panel. Conduit entry holes are provided on the top, bottom and right side of the panel. The panel should be mounted with sufficient space all around, depending on the complexity of the installation.

Main power wiring should conform to national and local electrical codes, and may require separate inspections and certification. Contact your local building authority for further details. If safety certification is required to obtain your occupancy certificate, Macurco can contract to provide testing services to obtain certification (such as the ETL label) by a national testing laboratory. Contact the Macurco Sales Department for further details.

2.2 General Wiring Information

WARNING

High voltage terminals (120/240 VAC) are located within the DVP-120, presenting a hazard to service technicians. Only qualified technicians should open the DVP-120 case and service the internal circuits. Ensure power is removed from the DVP-120 prior to servicing the unit.

With the exception of the safety ground, all field wiring is done via modular connectors (provided) so that the wiring can be done easily. After wiring, simply plug the modular connectors into the matching connectors on the PCB.

The power and signal connections to the remote mounted sensors should be size AWG18 (minimum) for short runs. Refer to Table 2-2 for recommended wire gauges. Four conductor cables may be used in all cases since the DVP-120 employs DC power for remote sensors to prevent electrical noise from interfering with the sensor output signal.

Do not bundle sensor power and/or signal connections with other AC power cables to prevent electrical interference. If other AC power connections must be bundled with the DVP-120 sensor cables, Macurco recommends that the sensor connections be made with two twisted pairs of the appropriate gauge, with an overall foil and braid shield. All shields should be terminated at the DVP-120 end of the cable only. A ground stud is provided near the bottom left corner of the panel.

Typical part numbers for AWG18 are:

- Alphawire 5132C
- Belden 1063A

2.3 Main power Connection

The main power cable should be routed into the bottom left conduit entry.

Macurco recommends a minimum wire size of AWG18 and the wire insulator must be rated for 60°C service. The modular connector will accept wire from 12 to 24 AWG.

The safety ground wire should be secured to the ground stud at the bottom left of the cabinet with the lock washer and nut supplied. Macurco recommends the use of a ring terminal for the ground connection.

Refer to Table 2-1 for DVP-120 power connections.

The line and neutral wires should be stripped 1/4 in. (6.5 mm), insert the wire into the wire cavity of the modular connector and tighten the screw clamp. Ensure that the wire cannot be easily pulled from the connector. Plug the modular connector into AC~ on the PCB and ensure that it latches into the header properly.

Signal	Connector	Pin Number
Line (120/220/240/250 VAC)	AC~	3
Neutral	AC~	1
Ground	Ground Stud	n/a

Table 2-1 Main Power Connections

2.4 Remote Sensor Connection

Each remote sensor is connected by a four-wire connection – two wires for DC power and two wires for the 4 – 20 mA loop connection. The sensors are connected to the control panel PCB with modular connectors, two sensors per connector. See Figure 2-1 for a view of a typical sensor connector. Refer to Table 2-2 for wire size recommendations.

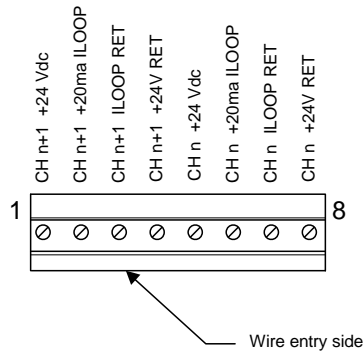

Figure 2-1 Sensor Interface Connector

Wire gauge	Maximum Run Length (ft.)	
	(feet)	(meters)
18	500	152
16	800	244
14	1250	381

Table 2-2 Recommended Wire Gauge

Each 8-terminal sensor modular connector may be disconnected from the PCB connector to ease wire installation. The terminals will accept wire from 16 to 28 AWG. To install a wire, strip back approximately 0.25 in. (6 mm) of insulation, and insert the bare wire into the terminal. Tighten the screw clamp and ensure that the wire cannot be easily pulled from the connector. Table 2-3 lists the connector to sensor channel correspondence. While Table 2-4 lists channel signals, connector and terminal assignments for all 12 input channels.

Control Board Connector	Sensor Channels
C1 C2	1, 2
C3 C4	3, 4
C5 C6	5, 6
C7 C8	7, 8
C9 C10	9, 10
C11 C12	11, 12

Table 2-3 Connector to Sensor Channel Mapping

Signal Name	Connector	Pin Number	Signal Name	Connector	Pin Number	Signal Name	Connector	Pin Number
CH 1 +24 Vdc	C1 C2	5	CH 5 +24 Vdc	C5 C6	5	CH 9 +24 Vdc	C9 C10	5
CH 1 +I loop	C1 C2	6	CH 5 +I loop	C5 C6	6	CH 9 +I loop	C9 C10	6
CH 1 -I loop	C1 C2	7	CH 5 -I loop	C5 C6	7	CH 9 -I loop	C9 C10	7
CH 1 24Vdc Ret	C1 C2	8	CH 5 24Vdc Ret	C5 C6	8	CH 9 24Vdc Ret	C9 C10	8
CH 2 +24 Vdc	C1 C2	1	CH 6 +24 Vdc	C5 C6	1	CH 10 +24 Vdc	C9 C10	1
CH 2 +I loop	C1 C2	2	CH 6 +I loop	C5 C6	2	CH 10 +I loop	C9 C10	2
CH 2 -I loop	C1 C2	3	CH 6 -I loop	C5 C6	3	CH 10 -I loop	C9 C10	3
CH 2 24Vdc Ret	C1 C2	4	CH 6 24Vdc Ret	C5 C6	4	CH 10 24Vdc Ret	C9 C10	4
CH 3 +24 Vdc	C3 C4	5	CH 7 +24 Vdc	C7 C8	5	CH 11 +24 Vdc	C11 C12	5
CH 3 +I loop	C3 C4	6	CH 7 +I loop	C7 C8	6	CH 11 +I loop	C11 C12	6
CH 3 -I loop	C3 C4	7	CH 7 -I loop	C7 C8	7	CH 11 -I loop	C11 C12	7
CH 3 24Vdc Ret	C3 C4	8	CH 7 24Vdc Ret	C7 C8	8	CH 11 24Vdc Ret	C11 C12	8
CH 4 +24 Vdc	C3 C4	1	CH 8 +24 Vdc	C7 C8	1	CH 12 +24 Vdc	C11 C12	1
CH 4 +I loop	C3 C4	2	CH 8 +I loop	C7 C8	2	CH 12 +I loop	C11 C12	2
CH 4 -I loop	C3 C4	3	CH 8 -I loop	C7 C8	3	CH 12 -I loop	C11 C12	3
CH 4 24Vdc Ret	C3 C4	4	CH 8 24Vdc Ret	C7 C8	4	CH 12 24Vdc Ret	C11 C12	4

Table 2-4 Sensor Connectors: Channel and Pin Assignments

2.5 Relay Connection

All poles of the three relays are available at the modular connector R1 R2 R3 (see Figure 2-2 for details). R1 R2 R3 is a 9-position variant of the high voltage modular connector used for power input. Each terminal can accommodate a wire size 12 to 24 AWG.

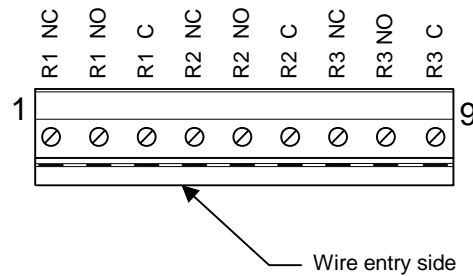

Figure 2-2 Relay Connector

To install the wiring for the relays, disconnect the connector from the header on the PCB. Strip the insulation of each wire back approximately 1/4 in. (6.5 mm), insert the bare wire into the terminal and tighten the screw clamp. Ensure that the wire cannot easily be pulled from the connector.

Note that the panel configuration can designate Relay-1 as an ALARM signal relay. Relay-2 and Relay 3 are general purpose in function.

Refer to Table 2-5 for output signals, connector and terminal assignment for all three relays.

Signal Name	Connector	Pin Number
Relay 1 NC	R1 R2 R3	1
Relay 1 NO	R1 R2 R3	2
Relay 1 Common	R1 R2 R3	3
Relay 2 NC	R1 R2 R3	4
Relay 2 NO	R1 R2 R3	5
Relay 2 Common	R1 R2 R3	6
Relay 3 NC	R1 R2 R3	7
Relay 3 NO	R1 R2 R3	8
Relay 3 Common	R1 R2 R3	9

Table 2-5 Relay Interface Signals and Connector Assignments

2.6 Horn & Strobe Connection

The external horn and strobe connections are available at the modular connector S H (see Figure 2-3 for details). S H as a 4-position connector, similar to the sensor interface connectors.

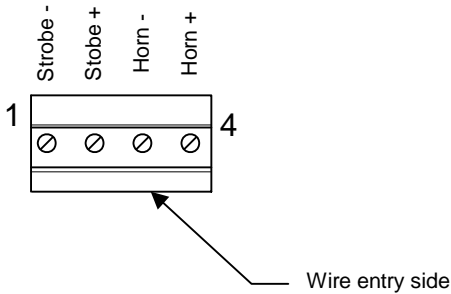

Figure 2-3 Horn & Strobe Connector

To install the wiring for the horn or strobe, disconnect the connector from the header on the PCB. Strip the insulation of each wire back approximately 0.25 in. (6 mm), insert the bare wire into the terminal and tighten the screw clamp. Ensure that the wire cannot easily be pulled from the connector.

When all wires are connected, seat the modular connector into the PCB header; ensure that the latch engages.

Refer to Table 2-6 for signals, connector and terminal assignment for the horn and strobe.

Signal Name	Connector	Pin Number
Horn +	S H	1
Horn -	S H	2
Strobe +	S H	3
Strobe -	S H	4

Table 2-6 Horn & Strobe signals and Connector Assignments

Refer to Table 2-7 for recommended wire gauge vs. run length for the horn & strobe functions (maximum 2.5 volt drop in the wire). The Strobe and Horn circuits are Class 2 control circuits so Class 2 conductors should be used.

Wire gauge	Maximum Run Length (ft.)	
	(feet)	(meters)
24	200	61
22	340	103
20	480	147
18	850	215

Table 2-7 Wire gauge for Horn & Strobe functions

2.7 Interfacing Macurco Sensors

All Macurco CO, NO₂ and combustible gas sensors with current loop outputs may be used with the DVP-120. Data sheets for the Macurco sensors listed in Table 2-8 are provided as an appendix to this manual.

Power connections to Macurco sensors used with the DVP-120 are polarity-insensitive, since a bridge rectifier is connected to the power input terminals. All sensors used with the DVP-120 panel employ screw clamp terminal blocks for power and signal connections.

Polarity of the current loop connections is marked on the printed circuit board of the sensor.

Description	Order Part Number
Carbon Monoxide Transducer with solid-state sensor	CM-2B
Carbon Monoxide Transducer with Electro-chemical sensor	CM-3
Nitrogen Dioxide Transducer with a 5A relay	ND-2
Combustible Gas Transducer	GT-11A

Table 2-8 Macurco Transducers

3 Operation

3.1 Initial Operating Mode

When power is first applied to the DVP-120, a few simple tests will be performed, e.g. cycle through all status lights, and display the system name and model # (Figure 3-1). The system will then proceed to normal mode, if the operating parameters have been entered.



DVP - 120 Ver 1.02

Figure 3-1 Model Display

If the user has not entered any parameters, the system WILL NOT be monitoring the sensors or controlling the ventilation system. The relays will be in the not actuated state and the horn and strobe outputs will be off. The power status light will show NORMAL (steady green) and the system will immediately enter the CONFIGURATION mode, see section 3.2 for details to set the configuration parameters.

If a valid set of configuration parameters have been entered, the panel will wait for all sensors to warm up. During this time, the display will show a count down, minutes and seconds, until the end of the warm-up period, Figure 3-2.

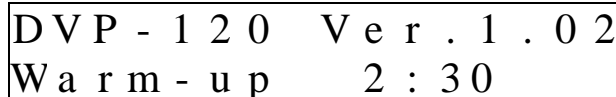

DVP - 120 Ver 1.02
Warm-up 2:30

Figure 3-2 Warm-Up display

During the warm-up period, the keypad will be locked. When the warm-up period ends, the LCD will start showing the normal display, Figure 3-4.

3.1.1 Status Light Display

The POWER, ALARM/WARNING, SILENCE, RELAY 1, RELAY 2 and RELAY 3 status lights indicate the system status and provide the following data:

- POWER
 - Green (steady) – Power is good and there are no trouble indications
 - Yellow (steady) – Trouble is indicated by a transducer or the panel itself
- ALARM/WARNING
 - Off – All indicated gas levels are below the warning level
 - Red (steady) – One or more gas levels is at or above the alarm level
 - Amber (steady) – One or more gas levels is at or above the warning level
- SILENCE
 - Off –There are no silenced alarms or warnings
 - Red (flashing) –There are alarms, warnings and/or troubles that have been silenced (gas levels may or may not still be at alarm or warning levels)
- RELAY 1
 - Off – Relay 1 is not on
 - Green (steady) – Relay 1 is on
- RELAY 2
 - Off – Relay 2 is not on
 - Green (steady) – Relay 2 is on
- RELAY 3
 - Off – Relay 3 is not on
 - Green (steady) – Relay 3 is on

The overall system status is visible at a distance via the status lights as described above. More detailed system information is displayed on the LCD, which can show the status of each relay and sensor. A typical status display is shown in Figure 3-4.

3.1.2 User Interface

The LCD display is used to show detailed information about the status of the control system and the configuration parameters to the user. The keypad (Figure 3-3) is used to select the information displayed and to enter the configuration parameters, which are stored in the DVP-120 non-volatile memory. The keypad consists of the usual ten digit keys, the normal four direction keys, plus a MENU key that is used to access the configuration menu and a HUSH key that will silence the audible alarm indicators.

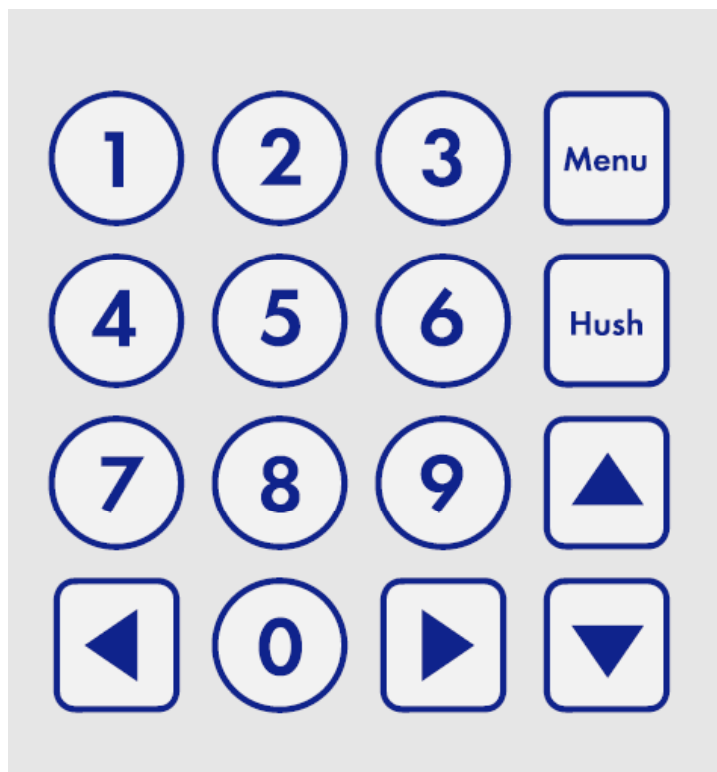

Figure 3-3 Keypad layout

In normal mode, no warnings or alarms that have not been silenced, the up and down cursor keys will scroll the display to any configured sensors' status.

In normal mode, the left and right cursor keys will scroll through all relays' status. When the left (or right) key is used to scroll to another relay the display will remove the underlining under the sensor number and underline the relay number, this indicates that the digit keys can be used to jump directly to a particular relay's status. When the up or down key is again used the display will switch back to the digit keys jumping to a particular sensor.

The MENU key has three functions. First, when the system is presenting the normal display, pressing the MENU key will cause the system to shift to the Configuration Menu. The second function of the MENU key is to return to the next-higher menu level, e.g. from the sensor configuration menu to the system menu, or from the system menu out to normal mode. If in the middle of entering a multi-digit parameter, the MENU key also cancels any changes to the parameter. When the MENU key is used to return to normal mode, any changed configuration parameters are saved in the DVP-120's non-volatile memory. The third function of the MENU key is to change the LCD contrast by holding the MENU key for five (5) seconds, at which point the LCD will prompt for further activities, see sections 4.4 for more detail.

The HUSH key is only used to silence the audible indicators (internal buzzer and possible external Horn and Strobe devices). Pressing and releasing the button will silence the internal buzzer. The HUSH button must be held for 3 seconds to silence the Horn and Strobe devices. See sections 3.1.4, 3.1.5 and 3.1.6 for more detail.

In normal mode, holding the zero key for three (3) seconds can be used to lock the keypad against accidental (or unauthorized) use. See section 4.5 for details.

3.1.3 Normal Status Display

MON	10	:	23	R1	OFF
S <u>0</u>	<u>1</u>	CO		5	PPM

Figure 3-4 Normal System Display

The display shows the day of the week and the time of day, in 24-hour format. It also shows the status of one of the relays, R1 in this example, and the type and indicated gas concentration of one of the configured sensors, S01 is a CO sensor indicating 5 ppm in this example.

Notice in Figure 3-4 that the digits 01 are underlined, this indicates that the digit keys can be used to jump directly to another sensor's status. When the first digit is pressed, the display will prompt for the second digit of the target sensor.

S	h	o	w	S	e	n	s	o	r	_	1
---	---	---	---	---	---	---	---	---	---	---	---

Figure 3-5 Sensor prompt

In this example, the first digit entered was 1. Since the DVP-120 can handle 12 sensors, the first digit for a sensor number is either 0 or 1. The leading zero must be entered when selecting a sensor less than ten. When the second digit is entered, the normal display will be restored; showing the type and value for the selected sensor.

As mentioned above, the left and right scroll keys will display the next (previous) relay's status. The display will also change the underline to indicate that the digit keys (zero, one and two) can be used to jump directly to a particular relay. Since only one digit is needed to select a relay, the system does it immediately rather than prompting to show the relay.

If the sensor is indicating a gas level that is greater than the alarm or warning levels the gas reading will alternate with the words ALARM or WARNING as appropriate. If the sensor is indicating a trouble condition the gas reading will be replaced by the word TROUBLE.

3.1.4 ALARM Status Display

When any sensor indicates a gas level that is at or above the configured alarm level for the sensor, the panel will enter ALARM mode, during which the internal buzzer will sound, the alarm lamp will be red and the LCD will show the sensor type and channel number.

ALARM
CO SENSOR 02

Figure 3-6 Alarm display

The display will cycle through all sensors that are signaling alarm levels, at five seconds per display. Pressing any key (except HUSH) will advance the display to the next sensor that is signaling an alarm level.

If an external horn and/or strobe are connected and configured to signal an alarm condition, they will also sound when an alarm condition occurs, after a delay if that configuration option is used.

When the HUSH key is pressed, the internal buzzer will be silenced for five (5) minutes. If the horn or strobe turn on delays have not finished then they will also be silenced. If the delays have finished the HUSH key must be held for three (3) seconds in order to silence the horn and strobe.

When all indicators have been silenced, the display will show that alarms have been silenced for five minutes. After any key press (or five seconds), the display will return to normal mode.

ALARM SILENCED
FOR 5 MINUTES

Figure 3-7 Alarm Silenced message

If Relay 1 has been configured as an ALARM relay it will be turned on when an alarm condition is recognized and will be turned off when **all** audio indicators have been silenced.

Silencing applies to the cause(s) of the alarm when the HUSH key is pressed.

3.1.5 Warning Status Display

When any sensor indicates a gas level that is at or above the configured warning level for the sensor, the panel will enter WARNING mode during which the internal buzzer will sound, the alarm/warning lamp will be amber and the LCD will show the sensor type and channel number.

WARNING
CO SENSOR 02

Figure 3-8 Warning display

The display will cycle through all sensors that are signaling warning levels, at five seconds per display. Pressing any key (except HUSH) will advance the display to the next sensor that is signaling a warning level.

If the buzzer and/or an external horn and/or external strobe are connected and configured to signal a warning condition, they will also sound when a warning condition occurs. There is a configurable delay before the horn or strobe will sound, see sections 3.3.5.3 and 3.3.6.3.

When the HUSH key is pressed, the internal buzzer will be silenced for fifteen (15) minutes. If the horn or strobe turn on delays have not finished then they will also be silenced. If the delays have finished, the HUSH key must be held for three (3) seconds in order to silence the horn and strobe.

When all indicators have been silenced, the display will show that warnings have been silenced for fifteen minutes. After any key is pressed (or five seconds) the display will return to normal mode.

WARNING SILENCED
FOR 15 MINUTES

Figure 3-9 Warning Silenced message

3.1.6 Trouble Status Display

If a sensor indicates a trouble, or the panel detects an internal fault, the panel will enter TROUBLE mode during which the internal buzzer will sound, the power lamp will be yellow and the LCD will show the problem.

T r o u b l e
C O S e n s o r 0 2

Figure 3-10 Trouble display

The display will cycle through all trouble indications, at five seconds per display. Pressing any key (except HUSH) will advance the display to the next trouble indicator.

If an external horn and/or strobe are connected and configured to signal a trouble condition, they will also sound when a trouble condition occurs, after a delay if that configuration option is used.

When the HUSH key is pressed, the internal buzzer will be silenced for eight (8) hours. If the horn or strobe turn on delays have not finished then they will also be silence. If the delays have finished, the HUSH key must be held for three (3) seconds in order to silence the horn and strobe.

When all indicators have been silenced, the display will show that trouble indications have been silenced for eight hours. After five seconds (or any key press), the display will return to normal mode.



TROUBLE SILENCED
FOR 8 HOURS

Figure 3-11 Trouble Silenced message

3.2 Ventilation control

The ventilation control function operates independently from the alarm function. It provides the ability to configure the DVP-120 for control of one to three zones. Each zone can respond to gas levels indicated by one or more of the three types of sensors, with configurable turn on and turn off concentrations for each gas type. Each zone can also be controlled based on the time of day and/or two of the sensor types.

Each zone can be configured to control one, two or all three of the relays and the external horn and strobe if desired. When more than one zone is controlling a relay it only takes one zone to activate the relay, but all controlling zones must release the relay before it will turn off.

Each of the relays, horn and strobe have independent turn on delays (to ignore short duration transients) and turn off delays (to ensure minimum run times for fans that must run for internal cooling).

3.2.1 Zone Signal Display

When a zone is controlling the horn or strobe and they turn them on, the panel will enter ZONE SIGNAL mode during which the horn and/or strobe will be turned on and the LCD will show the zone that is signaling.

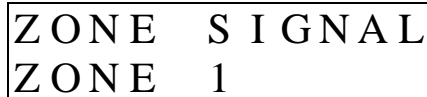

ZONE SIGNAL
ZONE 1

Figure 3-12 Zone Signal display

The display will cycle through all zones that are controlling the horn or strobe and are signaling, at five seconds per display. Pressing any key (except HUSH) will advance the display to the next zone that is signaling.

When the HUSH key is held for three (3) seconds, the horn and/or strobe will be silenced for fifteen (15) minutes. When silenced, the display will show that zone signals have been silenced for fifteen minutes. After any key is pressed (or five seconds) the display will return to normal mode.



ZONE SILENCED
FOR 15 MINUTES

Figure 3-13 Zone Signal Silenced message

3.3 Setting the System Configuration

The configuration menus can be entered from normal mode by pressing the MENU key. While in configuration mode, the user can review all configuration parameters to check the current operating conditions.

As an aid when configuring the control panel, the first entry in the top menu summarizes the number of sensors and relays that the panel is currently recognizing.



```
5 SENSORS FOUND
3 RELAYS FOUND
```

Figure 3-14 Hardware Summary

The MENU key is also used to return to a higher-level menu and finally exit the configuration menus back to normal mode.

When exiting from the menu system to normal mode, if any configuration changes have been made, the panel will ask whether changes are to be saved,

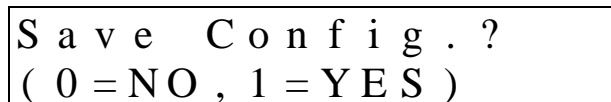

```
Save Config. ?
( 0 = NO , 1 = YES )
```

Figure 3-15 Save Configuration? Prompt

Pressing the zero (0) key at this point will cancel all changes except time and day of week. Pressing the one (1) will save all changes to non-volatile memory, and the changes will then become effective in controlling the ventilation system.

While the DVP-120 is in the configuration mode, alarm and ventilation control functions continue in the background with the previously set configuration values. In particular, if an alarm condition is detected the alarm lamp, the buzzer, the horn and the strobe will operate as configured but the LCD will not display the detailed information. The HUSH key can be used to silence any alarm, warning or trouble indicators without having to exit the configuration mode. If the MENU key is used to exit the configuration mode before using the HUSH key, the LCD will display the cause of the audible indicator.

The numeric keys are used to change the particular parameter displayed. The underlined character, or space, on each display indicates what will be changed by the digit keys.

The left and right cursor keys will enter the particular submenu and scroll through the items of the same type where appropriate, e.g. enter the Configure Sensors submenu and scroll through the parameter lists for the existing sensors.

The up cursor key scrolls through the menu entries in the order listed here, while the down cursor key scrolls in the reverse order.

Changing the configuration parameters requires the entry of a password before changes can be made. The default password is 1234. See Figure 3-23 for an example of the password prompt.

In many cases the parameter is entered as a string of digits, but some parameters are selected by pressing a single key, e.g. pressing 1 selects Monday, 2 selects Tuesday, etc.

3.3.1 System Menu

The top menu level allows the user to select:

- Configure System
- Configure Sensors
- Configure Relays, Horn & Strobe
- Configure Zones
- Configure Signals

The up and down cursor keys can be used to scroll through the entries in the list, while the left or right key will enter the particular submenu.

The MENU key will return to normal mode. If any configuration parameters have been changed, the panel will prompt to save the changes. If the changes are saved, this is the point **at which they become effective** in controlling the ventilation system and for alarm level detection. Note that changes to the time and day of week are not considered configuration items; they are saved as soon as they are entered.

3.3.2 Configure System Submenu

The system configuration submenu provides entries to:

- Set the time of day, 24 hour format
- Set the day of the week, day 1 is Monday
- Load Default Configuration
- Change Password

3.3.2.1 Set Time of Day

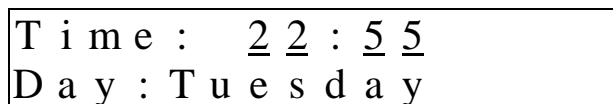

Time : 22 : 55
Day : Tuesday

Figure 3-16 Set Time of Day

This display example shows that the time is 22:55 (10:55 PM). The underlined characters indicate that the numeric keys can be used to set the current time of day. When the first digit is entered (and after the password is entered if required), the display will change to show that the hours portion of the time is currently being entered.

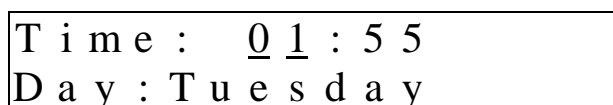

Time : 01 : 55
Day : Tuesday

Figure 3-17 Enter Hours

In this example the first digit entered was 1 (one), and the panel is waiting for the second digit of hours to be entered. If the second digit is not entered within five seconds, the time will revert to the previous value. After the second digit of the hours is entered, the display will prompt for the minutes entry:

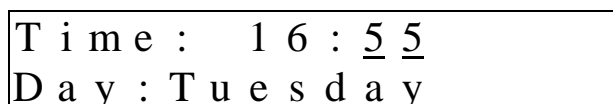

Time : 16 : 55
Day : Tuesday

Figure 3-18 Enter Minutes

In this example, the hours (16) have been accepted and the panel is waiting for the minutes to be entered. If no digits are entered for 5 seconds the entry will be finished without changing the minutes, however the hours will be changed to the value entered.

Note that the time is saved as soon as the fourth digit is entered.

3.3.2.2 Set Day of Week

Time : 22 : 55
Day : <u>2</u> Tuesday

Figure 3-19 Set Day of the week

This display example shows that Tuesday is the current day of the week. The underline character indicates that the day can be changed by entering the corresponding digit:

- 1 Monday
- 2 Tuesday
- 3 Wednesday
- 4 Thursday
- 5 Friday
- 6 Saturday
- 7 Sunday

Note that the day of the week is saved as soon as the digit is entered.

3.3.2.3 Load Default Configuration

<u>1</u> Load Default Configuration
--

Figure 3-20 Load Default Configuration

When the one (1) digit is pressed, the panel will prompt for the password, even if it has been entered previously. If the password is entered correctly, the panel will overwrite the existing configuration with the default configuration. This operation is intended to restore the panel to a known basic condition if it is removed from one installation and installed in another.

The default configuration is:

- Password 1234
- Sensors Undefined
- Alarm levels CO = 200 ppm, NO2 = 5.0ppm, EX = 4,000 ppm
- Warning Levels CO = 200 ppm, NO2 = 5.0 ppm, EX = 4,000 ppm
- Alarm signals Buzzer = Intermittent, Horn = Intermittent, Strobe = Continuous
- Warning signals Buzzer = Off, Horn = Off, Strobe = Off
- Trouble signals Buzzer = Triple Tap, Horn = Off, Strobe = Off
- Sensor Range CO = 200ppm, NO2 = 6.0 ppm, EX = 10,000 ppm
- Relay 1 Normally off, 1 minute turn on delay, 1 minute minimum on time
- Relay 2 Normally off, 1 minute turn on delay, 1 minute minimum on time
- Relay 3 Normally off, 1 minute turn on delay, 1 minute minimum on time
- Horn Normally off, 1 minute turn on delay, 0 (zero) minimum on time
- Strobe Normally off, 1 minute turn on delay, 0 (zero) minimum on time
- Zone1 Controls R1,
- Zone2 Controls R2,
- Zone3 Controls R3
- Group 1 in each zone Type 1 CO, Voting mode, Quorum = 1
- Group 2 in each zone Type 2 NO2, Voting mode, Quorum = 1
- Group 3 in each zone Type 3 EX, Voting mode, Quorum = 1
- Rising Trip Levels CO = 100 ppm, NO2 = 2.5ppm, EX = 2,000 ppm
- Falling Trip Levels CO = 50 ppm, NO2 = 1.2 ppm, EX = 1,000 ppm

3.3.2.4 Change Password

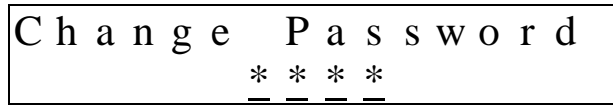
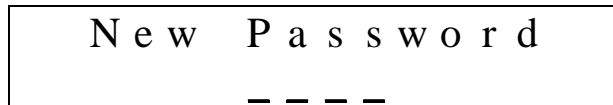

Figure 3-21 Change Password

- When the first digit is entered to change the password the panel will prompt for the existing password to be entered (if it hasn't already been entered), see section 3.3.2.5 for more detail.
- Once the current password has been entered, the panel will prompt for the new password.



3.3.2.5 Enter Password

- If the password has not yet been entered, then when the first digit of any parameter is entered the panel will prompt for the current password. Note that first digit entered is discarded; it does not count toward the password or toward the parameter entry.

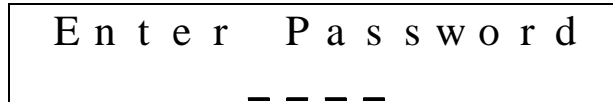

Figure 3-22 Enter Password

- When the first digit is entered, the panel will show.

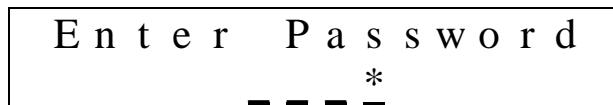

Figure 3-23 Password Prompt

- If the password is not entered correctly the panel will display

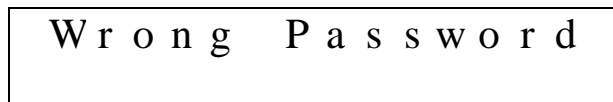

Figure 3-24 Wrong Password Prompt

- Once the current password has been entered, the panel will prompt for the configuration parameter being changed.

3.3.3 Configure Sensors Submenu

There is a list of parameters for each sensor in the system, either currently wired or configured but presently disconnected. The left and right cursor keys can be used to move from one sensor to another; doing so always goes to the first display (summary). The up and down keys will scroll through the parameters for the particular sensor.

3.3.3.1 Sensor Summary

```
S e n s o r   0 1           C O
A :   2 0 0       W :   5 0
```

Figure 3-25 Sensor Summary

This display example shows that the sensor on channel 01 has been configured as a Carbon Monoxide sensor with an Alarm level of 200 ppm and a Warning level of 50 ppm.

Notice that the sensor number, 01 in this example, is underlined. This indicates that the digit keys can be used to jump to a particular channel, even if there is no sensor connected to the channel. When the first digit is entered, the display will prompt for the sensor to show.

3.3.3.2 Sensor Type

```
S e n s o r   0 1           C O
T y p e : 1
```

Figure 3-26 Sensor Type

This display example shows that the sensor on channel 01 has been configured as a Carbon Monoxide sensor. The valid entries for the sensor type are:

- 1 Carbon Monoxide (CO)
- 2 Nitrogen Dioxide (NO2)
- 3 Combustible (EX)
- 0 None (---

Setting the sensor type to 0 (zero) will cause the display to ask if the user wants to DELETE the sensor. If the answer is yes, the configuration record for this sensor channel will be deleted and the channel will no longer be used to control the ventilation system. If a sensor indicates trouble (or there are wiring problems on a channel), this will stop any annoying trouble signals for this channel.

When a sensor's type is changed, the alarm level, warning level and range will be set to the default for the sensor type.

The following three parameters are not accessible until a sensor type of 1, 2 or 3 is selected.

3.3.3.3 Alarm Set Point

```
S e n s o r   0 1           C O
A l a r m :           2 0 0 p p m
```

Figure 3-27 Sensor's Alarm Level

The default alarm levels for the sensors are:

- Carbon Monoxide 200 ppm
- Nitrogen Dioxide 5.0 ppm
- Combustible 4,000 ppm (10% LEL for methane)

Setting an alarm level of 0 (zero) will disable alarm detection for this particular sensor.

3.3.3.4 Warning Set Point

S e n s o r	0 1	CO
W a r n i n g :	_ <u>5</u> <u>0</u> p p m	

Figure 3-28 Sensor's Warning Level

The default warning levels for the sensors are:

- Carbon Monoxide 200 ppm
- Nitrogen Dioxide 5.0 ppm
- Combustible 4,000 ppm (10% LEL for methane)

Setting a warning level of 0 (zero) will disable warning detection for this particular sensor.

3.3.3.5 Range

S e n s o r	0 1	CO
R a n g e :	<u>2</u> <u>0</u> <u>0</u> p p m	

Figure 3-29 Sensor's Range

The range for each sensor is the gas concentration that corresponds to the 20 mA signal level.

The default range values for the sensors are:

- Carbon Monoxide 200 ppm
- Nitrogen Dioxide 6.0 ppm
- Combustible 10,000 ppm (25% LEL for methane)

3.3.4 Configure Relays, Horn & Strobe Submenu

There is a list of parameters for each relay in the system. The left and right cursor keys can be used to move from one relay, horn or strobe to another. Doing so always goes to the first (summary) display. The up and down keys will scroll through the parameters for the particular relay, horn or strobe.

3.3.4.1 Relay Summary

```
Relay  1  Norm . Off  
Delay  On , Min . On
```

Figure 3-30 Relay Summary

This display example shows that Relay 1 is configured to operate Normally Off, with a turn on delay and a minimum on time.

Notice that the relay number, 1 in this example, is underlined. This indicates that the digit keys can be used to jump to a particular relay, horn or strobe. The relays are numbers 1, 2 and 3; the horn is number 4 and the strobe is 5.

3.3.4.2 Relay Mode

```
Relay  1  Norm . Off  
Mode : 2
```

Figure 3-31 Relay Mode

This display example shows that relay 1 is configured to operate in the Normally Off mode. The relay modes are:

- 1 ALARM
- 2 Normally Off (default)
- 3 Normally On

Relay mode 1 is a special case. This mode is only available on relay 1 and dedicates the relay to function as an alarm signal to a subsequent alarm or monitoring panel. This mode forces the relay to normally off mode with no turn on delay or minimum on time. See section 3.1.4 for more detail regarding alarms

Fail Safe operation can be implemented by configuring a relay to operate Normally On, and wiring the circuit using the NC (normally closed) contact. In this way, if the control panel loses power the relay will turn on the controlled device if it still has power.

3.3.4.3 Relay Turn On Delay

```
Relay  1  Delay  On  
( mm : s s )  01 : 0 0
```

Figure 3-32 Turn On Delay

The default turn on delay is one minute and the maximum allowed value is fifteen minutes. The value is entered in two groups, 2 digits for the minutes and then 2 digits for the seconds. A leading zero must be entered for each group if applicable.

3.3.4.4 Relay Minimum On Time

```
Relay  1      Min . On  
( mm : s s )  01 : 0 0
```

Figure 3-33 Minimum on time

The default minimum on time is one minute and the maximum allowed value is fifteen minutes.

3.3.5 Configure Horn Submenu

The configuration parameters for the horn are the same as those for relays. A horn would not normally require a minimum on time but this parameter allows a more versatile configuration.

3.3.5.1 Horn Summary

```
H o r n   4   N o r m . O f f
D e l a y   O n
```

Figure 3-34 Horn Summary

This display example shows that the horn has been configured to operate Normally Off, with a turn on delay and no minimum on time.

Notice that the horn number, 4, is underlined. This indicates that the digit keys can be used to jump to a particular relay, horn or strobe. The relays are numbers 1, 2 and 3; the horn is number 4 and the strobe is 5.

3.3.5.2 Horn Mode

```
H o r n           N o r m . O f f
M o d e : 2
```

Figure 3-35 Horn Mode

This display example shows that the horn is configured to operate in the Normally Off mode. The valid modes are:

- 2 Normally Off (default)
- 3 Normally On

3.3.5.3 Horn Turn On Delay

```
H o r n           D e l a y   O n
( m m : s s )   01 : 0 0
```

Figure 3-36 Horn Turn On Delay

The default turn on delay is one minute and the maximum allowed value is fifteen minutes.

3.3.5.4 Horn Minimum On Time

```
H o r n           M i n . O n
( m m : s s )   00 : 0 0
```

Figure 3-37 Horn Minimum on time

The default minimum on time is zero and the maximum allowed value is fifteen minutes.

3.3.6 Configure Strobe Submenu

The configuration parameters for the strobe are the same as those for relays. A strobe would not normally require a minimum on time but this parameter allows a more versatile configuration.

3.3.6.1 Strobe Summary

```
S t r o b e 5 N o r m . O f f
D e l a y   O n
```

Figure 3-38 Strobe Summary

This display example shows that the strobe has been configured to operate Normally Off, with a turn on delay and no minimum on time.

Notice that the strobe number, 5, is underlined. This indicates that the digit keys can be used to jump to a particular relay, horn or strobe. The relays are numbers 1, 2 and 3; the horn is number 4 and the strobe is 5.

3.3.6.2 Strobe Mode

```
S t r o b e      N o r m . O f f
M o d e : 2
```

Figure 3-39 Strobe Mode

This display example shows that the strobe is configured to operate in the Normally Off mode. The valid modes are:

- 2 Normally Off (default)
- 3 Normally On

3.3.6.3 Strobe Turn On Delay

```
S t r o b e      D e l a y   O n
( m m : s s )   0 1 : 0 0
```

Figure 3-40 Strobe Turn On Delay

The default turn on delay is one minute and the maximum allowed value is fifteen minutes.

3.3.6.4 Strobe Minimum On Time

```
S t r o b e      M i n . O n
( m m : s s )   0 0 : 0 0
```

Figure 3-41 Strobe Minimum on time

The default minimum on time is zero and the maximum allowed value is fifteen minutes.

3.3.7 Configure Zones Submenu

The DVP-120 ventilation control can support up to three zones. The zone functionality makes the DVP-120 very flexible. For example, each zone can be configured to monitor a separate set of four sensors and control a single relay.

Another control scheme uses one zone to monitor all sensors and turn one relay on at a relatively low gas concentration. A second zone monitors the same sensors and turns on a second relay if the gas concentration reaches a higher level. The third zone can also monitor the same relays turning the last relay on as a signaling device to a live monitor station, as well as turning on the external horn and strobe, under the assumption that the ventilation system is not working.

In addition to controlling the relays based on the gas concentration, each zone can have a timed function, e.g. turn on low volume ventilation fans at 7:00 AM and turn them off at 8:00 PM.

The default Ventilation Controls are:

- Zone 1 controls Relay 1
- Zone 2 controls Relay 2
- Zone 3 controls Relay 3
- In each zone
 - Group 1 is type 1 (CO),
 - default Rising (100 ppm) and Falling (50 ppm) trip points,
 - Voting mode,
 - Quorum of 1.
 - Group 2 is type 2 (NO2),
 - default Rising (2.5 ppm) and Falling (1.2 ppm) trip points,
 - Voting mode,
 - Quorum of 1.
 - Group 3 is type 3 (EX),
 - default Rising (2,000 ppm) and Falling (1,000 ppm) trip points,
 - Voting mode,
 - Quorum of 1.

3.3.7.1 Zone Controls

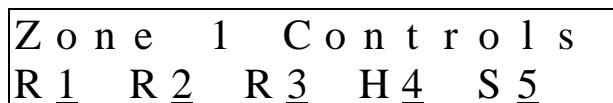

Figure 3-42 Zone Controls

This display example shows that Zone 1 is configured to control all of the relays plus the horn and the strobe. Each of the relays, the horn and the strobe can be removed from (or added to) the zones control by pressing the indicated digit key. By default, Zone 1 will control Relay 1, Zone 2 will control Relay 2 and Zone 3 will control Relay 3.

The digit controls are:

- 1 Relay 1 added/removed form the zone's control
- 2 Relay 2 added/removed form the zone's control
- 3 Relay 3 added/removed form the zone's control
- 4 Horn added/removed form the zone's control
- 5 Strobe added/removed form the zone's control

When controlled by a zone the default horn pattern is the Triple Tap pattern, see 3.3.8.7 and the strobe will turn on continuously when a zone is controlling them.

Each zone can have up to three control groups defined. Each group either monitors a sensor type or implements a timer function.

3.3.7.2 Zone Group Type

```
Z 1   G r o u p   1       N O 2
S e n s o r   T y p e :  2
```

Figure 3-43 Zone Group Type

This display example shows that group 1 in zone 1 will be monitoring Nitrogen Dioxide sensors. The valid Types are:

- 0 Timed
- 1 Carbon Monoxide (CO)
- 2 Nitrogen Dioxide (NO2)
- 3 Combustible (EX)

The default Types are:

- Group 1 in each zone is Type 1, i.e. monitors CO sensors
- Group 2 in each zone is Type 2, i.e. monitors NO2 sensors
- Group 3 in each zone is Type 3, i.e. monitors EX sensors

Timed mode turns the zone's outputs on at the START TIME if the current day is a weekday (or a weekend) and turns them off at the next occurrence of STOP TIME. The other three modes turn the outputs on if the gas concentration indicated by that type of sensor is at or above the Rising Trip Point and turns the outputs off if the concentration is less than or equal to the Falling Trip Point.

3.3.7.3 Timed Day Selection

```
Z 1   G r o u p   1   T i m e d
D a y s :  1       W e e k d a y s
```

Figure 3-44 Timer Days Selection

Valid entries are:

- 1 Weekdays, Monday thru Friday, (default)
- 2 Weekends, Saturday and Sunday

3.3.7.4 Start Time

```
Z 1   G r o u p   1   T i m e d
S t a r t   T i m e :  0 7 : 0 0
```

Figure 3-45 Start Time Selection

The start time is entered in 24-hour format and the default value is 07:00 (7:00 AM).

3.3.7.5 Stop Time

```
Z 1   G r o u p   1   T i m e d
S t o p   T i m e :  1 8 : 0 0
```

Figure 3-46 Stop Time Selection

The stop time is entered in 24-hour format and the default value is 18:00 (7:00 PM).

3.3.7.6 Sensor Selection

```
Z 1   G r o u p   1       N O 2
S e n s o r s : 0 2 , 0 4 , 1 1
```

Figure 3-47 Sensor Selection

Sensors are included or removed from the group by entering the two-digit channel number. After a sensor is added or removed the list will be re-sorted so it does not matter in which order the sensors are added or removed. The default is to include all sensors of the specified type.

When the first digit of a sensor number is entered (a leading zero must be entered if the number is less than ten), the display will prompt to Add or Remove a sensor from the group.

```
Z 1   G r o u p   1       N O 2
A d d / R e m o v e : _ 0
```

Figure 3-48 Add/Remove sensor prompt

When the second digit is entered, the sensor will be added or removed from the control group, provided the sensor is of the proper type, NO2 in this example. If the sensor is of the wrong type, or an invalid sensor channel number is entered the request will be simply ignored.

3.3.7.7 Rising Trip Point

```
Z 1   G r o u p   1       N O 2
R i s i n g :           2 . 5 p p m
```

Figure 3-49 Rising Trip Point Entry

The default rising trip points are:

- Carbon Monoxide 100 ppm
- Nitrogen Dioxide 2.5 ppm
- Combustible 2,000 ppm

3.3.7.8 Falling Trip Point

```
Z 1   G r o u p   1       N O 2
F a l l i n g :         1 . 0 p p m
```

Figure 3-50 Falling Trip Point Entry

The default falling trip points are:

- Carbon Monoxide 50 ppm
- Nitrogen Dioxide 1.2 ppm
- Combustible 1,000 ppm

3.3.7.9 Multiple Sensor Mode

Z 1	G r o u p	1	N O 2
M o d e :	<u>2</u>	V o t i n g	

Figure 3-51 Sensor Mode Selection

When multiple sensors are being monitored by a group the output decision can be based on either voting, as shown here, or the average of all sensors in the group. Valid modes are:

- 1 Average
- 2 Voting (default)

When the configuration is Average, the gas concentrations from all sensors in the group are averaged and if the average is greater than or equal to the rising trip point the zone output(s) are activated. When the average is less than or equal to the falling trip point the zone output(s) are de-activated. If the average is between the two trip points, the outputs remain in there previous state.

When the configuration is Voting, the number of sensors in the group indicating a value greater than or equal to the rising trip point is counted. If the count is greater than or equal to the quorum then the zone output(s) are activated. If the count of sensors indicating less than or equal to the falling trip point is greater than or equal to the quorum the zone output(s) are de-activated. Activating the output(s) is given priority if a group has an equal number of sensors with gas readings \geq the rising trip point and sensors with readings \leq the falling trip point.

3.3.7.10 Multiple Sensor Quorum

Z 1	G r o u p	1	N O 2
Q u o r u m :	<u>2</u>		

Figure 3-52 Quorum Entry

It is up to the installer to ensure that the quorum entry is appropriate for the configuration. Valid entries are one to twelve, but a value greater than the number of sensors being monitored by the group, stops the group from controlling the outputs. The default quorum value is 1.

3.3.8 Configure Signals Submenu

The DVP-120 can drive the buzzer, horn and strobe with different sound patterns to indicate the severity of the current conditions. These patterns are selectable by the installer using this group of submenus. Once again, the left and right keys will scroll through the signal types and the up and down keys will scroll to the signal sources.

3.3.8.1 Alarm Signal Summary

The alarm signals are in response to one or more sensors indicating gas levels at or above the sensors' configured alarm level.

```
A l a r m   S i g n a l s
B u z z , H o r n , S t r o b e
```

Figure 3-53 Alarm Signals

This display example shows that alarms are signaled by the internal Buzzer, the external horn and the strobe.

3.3.8.2 Alarm Buzzer Signal

```
A l a r m   S i g n a l s
B u z z : 2   I n t e r m i t .
```

Figure 3-54 Buzzer Alarm Signal

This display example shows that the buzzer will signal an alarm condition with an intermittent signal. The signal definitions are:

- 1 Continuous
- 2 Intermittent, one second on at two second intervals (default)
- 3 Double Tap, two beeps at 5 second intervals
- 4 Triple Tap, three short beeps at 15 second intervals
- 5 Off, buzzer will not sound

3.3.8.3 Alarm Horn Signal

```
A l a r m   S i g n a l s
H o r n : 2   I n t e r m i t .
```

Figure 3-55 Horn Alarm Signal

This display example shows that the buzzer will signal an alarm condition with an intermittent signal. The signal definitions are:

- 1 Continuous
- 2 Intermittent, one second on at two second intervals (default)
- 3 Double Tap, two beeps at 5 second intervals
- 4 Triple Tap, three short beeps at 15 second intervals
- 5 Off, horn will not sound

3.3.8.4 Alarm Strobe Signal

```
Alarm Signals  
Strobe : 1 Contin .
```

Figure 3-56 Strobe Alarm Signal

This display example shows that the strobe will signal an alarm condition with a continuous signal. The signal definitions are:

- 1 Continuous (default)
- 2 Intermittent, one second on at two second intervals
- 3 Double Tap, two beeps at 5 second intervals
- 4 Triple Tap, three short beeps at 15 second intervals
- 5 Off, strobe will not flash

3.3.8.5 Warning Signal Summary

The warning signals are in response to one or more sensors indicating gas levels at or above the sensors' configured warning level.

```
Warning Signals  
B u z z
```

Figure 3-57 Warning Signals

This display example shows that warnings are signaled by the internal Buzzer only.

3.3.8.6 Warning Buzzer Signal

```
Warning Signals  
B u z z : 5 O F F
```

Figure 3-58 Buzzer Warning Signal

This display example shows that the buzzer will not signal a warning condition. The signal definitions are:

- 1 Continuous
- 2 Intermittent, one second on at two second intervals
- 3 Double Tap, two beeps at 5 second intervals
- 4 Triple Tap, three short beeps at 15 second intervals
- 5 Off, buzzer will not sound (default)

3.3.8.7 Warning Horn Signal

```
Warning Signals  
H o r n : 5 O F F
```

Figure 3-59 Horn Warning Signal

This display example shows that the horn will not signal a warning condition. The signal definitions are:

- 1 Continuous
- 2 Intermittent, one second on at two second intervals
- 3 Double Tap, two beeps at 5 second intervals
- 4 Triple Tap, three short beeps at 15 second intervals
- 5 Off, horn will not sound (default)

3.3.8.8 Warning Strobe Signal

```
Warning Signals
Strobe : 5      OFF
```

Figure 3-60 Strobe Warning Signal

This display example shows that the strobe will not signal a warning condition. The signal definitions are:

- 1 Continuous
- 2 Intermittent, one second on at two second intervals
- 3 Double Tap, two beeps at 5 second intervals
- 4 Triple Tap, three short beeps at 15 second intervals
- 5 Off, strobe will not flash (default)

3.3.8.9 Trouble Signal Summary

The trouble signals are in response to one or more sensor faults, either as a defined current level, or because of wiring problems

```
Trouble Signals
Buzz
```

Figure 3-61 Trouble Signals

This display example shows that troubles are signaled by the internal Buzzer only.

3.3.8.10 Trouble Buzzer Signal

```
Trouble Signals
Buzz : 4      Triple
```

Figure 3-62 Buzzer Trouble Signal

This display example shows that the buzzer will signal a trouble condition with a triple tap signal. The signal definitions are:

- 1 Continuous
- 2 Intermittent, one second on at two second intervals
- 3 Double Tap, two beeps at 5 second intervals
- 4 Triple Tap, three short beeps at 15 second intervals (default)
- 5 Off, buzzer will not sound

3.3.8.11 Trouble Horn Signal

```
Trouble Signals
Horn : 5      OFF
```

Figure 3-63 Horn Trouble Signal

This display example shows that the horn will not signal a trouble condition. The signal definitions are:

- 1 Continuous
- 2 Intermittent, one second on at two second intervals
- 3 Double Tap, two beeps at 5 second intervals
- 4 Triple Tap, three short beeps at 15 second intervals
- 5 Off, horn will not sound (default)

3.3.8.12 Trouble Strobe Signal

T r o u b l e S i g n a l s
S t r o b e : <u>5</u> O F F

Figure 3-64 Strobe Trouble Signal

This display example shows that the strobe will not signal a trouble condition. The signal definitions are:

- 1 Continuous
- 2 Intermittent, one second on at two second intervals
- 3 Double Tap, two beeps at 5 second intervals
- 4 Triple Tap, three short beeps at 15 second intervals
- 5 Off, strobe will not flash (default)

4 Troubleshooting

The DVP-120 is extensively tested at the factory to ensure reliable operation. Most problems can be traced to the set-up of configurable features and modes, system wiring or trouble with the sensors.

4.1 System Status Light Flashing

The system status light (section 3.1.1) is normally green indicating power is present, but will change to yellow whenever the controlling firmware detects a trouble condition. Possible trouble conditions are

- Any configured channel has less than 4 mA flowing in the current loop
- A sensor is reporting a trouble condition
- Any configured channel wiring is open.
- Internal controller board problems are detected.

4.1.1.1 Input Channel Trouble

Any time the POWER light is yellow, the first thing the technician should consider is that one of the input channels is in trouble. Reviewing the Sensor Status displays (using the up and down keys), should reveal which channel has a problem since the gas reading will be replaced with the word TROUBLE.

A common source of trouble is an input channel that is configured for a sensor that does not exist. In this case, the system expects to see current flowing within the current loop, but there cannot be current if there is no sensor connected. Either fix the miss-wired sensor, or change the sensor type to NONE, section 3.3.3.2. After returning to normal mode (using the MENU key), the power light should return to steady green.

If all channels are configured properly, another source of trouble could be the type of sensor attached to an input channel. Macurco Toxic sensors can indicate high gas concentrations with signals of up to 24 mA in the current loop. However, the combustible sensor (GT-11A) can indicate trouble with a 21 mA signal. Therefore, a Toxic sensor connected to channel which is configured for a combustible sensor can cause a fault indication if the gas concentration is high enough.

All Macurco sensors are either supplied with a STATUS lamp that will indicate the health of the device, or will display a trouble message on the digital display. Macurco sensors may be tested by depressing the TEST button on the sensor printed circuit board, or (depending on the type of sensor), the button on the interior front panel of the unit. Macurco sensors will step the output current level from 4 mA to 20 mA over the course of the warm-up period, allowing the technician to determine where the trouble exists. If the sensor is still in trouble, resetting the power may clear the trouble. Remove one of the power wires from the sensor terminal strip causing the sensor to go through a power-up reboot.

Finally, the wiring between the DVP-120 and the sensor should be investigated. The power input to the sensor should be investigated *at the sensor*. Since Macurco sensors are rated for operation between 12 and 24 VDC or VAC, the voltage drop between the DVP-120 and the sensor should not be an issue if the wiring guidelines in Table 2-2 are followed. A multimeter can be inserted to check the current flow within the loop, or a continuity test can be performed on all four wires between the DVP-120 and the sensor. Ensure power is removed from the DVP-120 prior to removing the input or output connectors from the DVP-120 controller board.

Each sensor channel is provided with a PTC-resettable fuse internal to the DVP-120 to protect against over current situations. To reset a sensor channel, power should be removed from the channel. This can be accomplished by removing power from the sensor – causing the loop current to go to zero, or by completely removing power from the DVP-120.

4.1.1.2 Internal Controller Board Trouble

If the sensor status display and investigative efforts reveal no problems with the input channel current loops and channel configuration, the most likely trouble is an internal problem detected by the DVP-120 controller. In this case, contact the Macurco Technical Department for advice and help.

4.2 Timed ventilation problem

When using the timed ventilation mode the system clock should be checked regularly (at least twice a year). The battery backed real time clock in the DVP-120 does not adjust for daylight saving time so the spring and fall switch over points are good choices to check the system clock.

4.3 No Power

WARNING

120/240 VAC terminals are located within the DVP-120, presenting a hazard to service technicians. Only qualified technicians should open the DVP-120 case and service the internal circuits. Ensure power is removed from the DVP-120 prior to servicing the unit.

The DVP-120 starts up as soon as power is applied to the microcontroller, and the DVP-120 is designed to have power *continuously* applied to the unit. An external indication of successful power application to the unit is the immediate operation of the Status Lamps grouped around the LCD. If the operator does not see immediate response from the status lamps, power should be checked at AC~ (refer to Figure 1-2 for connector locations).

If the correct voltage is noted at AC~, then the internal fuse of the DVP-120 should be investigated. The DVP-120 is protected from over-current and transient situations by the fuse at F3. AFTER removing power from the DVP-120, F3 can be checked by removing the safety cover. If necessary, replace F3 with a 5x20 mm SLO-BLO fuse with a rating of 1 Amp 250V, e.g. LittelfuseP/N 218001. Be sure to REPLACE THE SAFETY COVER on F3 before re-applying power to the DVP-120.

4.4 LCD Display unreadable

It is possible that the LCD is unreadable due to temperature or aging of the control panel. If this is the case the following steps should rectify the problem:

- Hold the MENU key for three (3) seconds.
After three seconds, the power led will turn red. After a further two seconds, the LCD backlight will also be turned off.
- Press the UP and DOWN cursor keys to change the LCD contrast.
Each press of the UP or DOWN cursor key will change the contrast by a step in that direction. Adjust the contrast for best viewing.
- Press any other key to exit the contrast-setting mode.

4.5 The Keypad does not respond (LCD shows KEYS LOCKED)

The keypad can be unlocked by holding the zero (0) key for three seconds. At which time the backlight will turn on and the display will return to normal mode.

The keypad can again be locked by holding the zero key for three seconds, until the display shows KEYS LOCKED.

4.6 The Keypad does not respond after silencing an Alarm, Warning or Trouble.

LCD continues to show the alarm, warning or trouble message.

It is possible that the horn or strobe have been configured to respond in alarm, warning or trouble conditions, even though there is no horn or strobe connected (or perhaps they are used for some purpose that is not audible or visible).

First, hold the HUSH key for five seconds, or until the display changes to “ALARM silenced for 5 minutes” or other relevant message.

Second, use the configuration menu to disable the horn or strobe, if they are not being used for some other purpose.

4.7 After a power failure

After any power failure, the user should check the system clock. While system parameters are maintained in non-volatile memory, the system clock is backed-up by a limited-capacity button cell battery. Even though the button cell can run the clock for several years, it will eventually wear out.

4.8 Appendix A – Quick Set-up

Note 1: Default Password is 1234

Note 2: When entering multiple digit values the Up key (↑) acts as an enter key when it is not necessary to enter all allowed fields. Any other key is ignored or cancels the current parameter change.

Starting from normal mode

Section 1: Configure Sensors

Press Menu

↑↑ Configure Sensors

→ Sensor

↑ Sensor type

1=CO, 2=NO2, 3=Combustible, 0=None

↑ Alarm Level, Set level if needed, 0 = disable

↑ Warning Level, Set level if needed

↑ Sensor Range, default range is in system

→ Next Sensor, complete for all sensor channels.

Section 2: Configure Relays

Press Menu

↑Configure Relays

→ Relay 1

Default

Normally Off

Delay on 1 Minute

Minimum Runtime / Off Delay 1 Minute

→ Relay 2, repeat for all relays, horn and strobe

Section 3: Configure Zones

Definitions:

Zone – Defines Sensor Input & Relay / Alarm Output

Group – Set of Sensors of same type and output within the same zone.

Average – Activation based upon an average of sensors in a group

Voting – Number of sensors needed to be above trip point to activate output

Quorum – Number of sensors need to vote, 1 = any sensor.

Press Menu

↑ Configure Zones

→ Zone 1 Controls

R_ R_ R_ H_ S_

Enter number of output for zone

R = Relay (1,2,3)

H = Horn (4)

S = Strobe (5)

↑ Configure Group 1

Sensor type, Enter #

1=CO, 2=NO2, 3=Combustible, 0=None

↑ Sensor Number, ## enter two digit code for each sensor to be in the group

↑ Rising (actuation) Trip point

↑ Falling (off) Trip point

↑ Average, Voting

→ Configure Group 2, repeat for up to three groups

Section 4: Configure Signals

Press Menu

↑ Configure Signals

→ Alarm Signals

↑ Alarm Signal Buzzer (default 2 – Intermittent)

↑ Alarm Signal Horn (default 2 – Intermittent)

↑ Alarm Signal Strobe (default 1 – Continuous)

→ Warning Signals

↑ Warn Signal Buzzer (default 5 – Off)

↑ Warn Signal Horn (default 5 – Off)

↑ Warn Signal Strobe (default 5 – Off)

→ Trouble Signals

↑ Trouble Signal Buzzer (default 4 – Triple Tap)

↑ Trouble Signal Horn (default 5 – Off)

↑ Trouble Signal Strobe (default 5 – Off)

Section 5: Save Configuration

Press Menu twice

Press 1 to Answer YES

Returns to normal mode