

The IS-L101 beacon is CE marked for compliance with the European Explosive Atmospheres Directive 94/9/EC and the European EMC Directive 89/336/EEC

1. INTRODUCTION

The IS-L101L is an ATEX and IECEx certified intrinsically safe beacon which will produce a visual warning in a hazardous area. Red, Amber, Green and Blue output models are available.

The beacon has been designed and certified to work alone or in conjunction with a European Safety Systems IS-A105N intrinsically safe sounder. The beacon may be powered from the same intrinsically safe circuit as the IS-A105N intrinsically safe sounder, allowing a combined audible and visual alarm to be constructed. The IS-L101L beacon also contains an alarm accept facility which allows an operator to silence the sounder for a predetermined time while leaving the beacon flashing or the sounder can be silenced after a predetermined time period has elapsed.

When using the IS-L101L beacon with an IS-A105N sounder, the Special Conditions for Safe Use in the sounder certificate, Sira 04ATEX2301X must also be met.

2. DESCRIPTION

Fig 1 shows a simplified block diagram of a IS-L101L beacon. The device will start to flash when power is applied to terminals + and -. Terminals S+ and S- are for the connection of an optional IS-A105N sounder which will operate immediately power is applied to the beacon. The sounder may be silenced for a predetermined time by momentarily connecting the Ac.Sw terminals together. The silence time is set by DIP switches 1 to 4 for time periods between 5 seconds and 2 hours. **By setting DIP switch 5 to ON the sounder will silence after a preset time, but sound will not be restored until the power to the beacon has been removed and restored.** Setting DIP switch 6 to ON will provide a 1 second reminder beep tone sound while the sounder is silenced. The interval between the 1 second reminder beep is dependent on the timing setting for the silence period, (switches 1 to 4) see page 5. **When the beacon is operated alone, without a sounder connected, all of the DIP switches should be set to the OFF position.**

When used alone, i.e. without a sounder connected, two flash frequencies may be selected. With the Ac.Sw terminals disconnected the beacon will produce two flashes in quick succession once per second. The flash frequency can be doubled by permanently connecting the Ac.Sw terminals together.

When used with a sounder, the beacon produces two flashes in quick succession once per second. When the sounder is silenced the flash frequency is automatically doubled.

3. SUPPLY VOLTAGE

The IS-L101L beacon has been designed to operate in a hazardous area via 28V 660mA 1.2W ATEX and IECEx certified Zener Barriers or Galvanic Isolators. The beacon may be tested or used in safe areas without a Zener Barrier or Galvanic Isolator, but at supply voltages above 16V the internal current limit will function and the brightness may be reduced. The beacon should not be continuously operated without a barrier or isolator with a supply voltage greater than 16V.

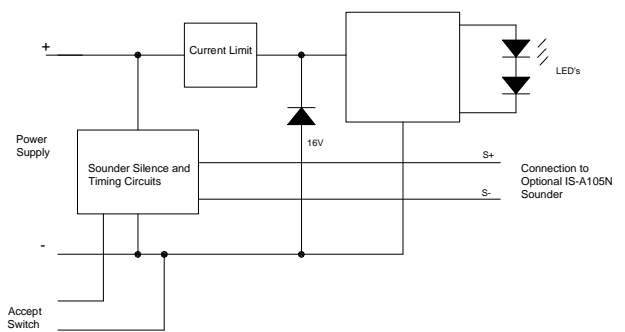

Fig 1 Simplified block diagram

4. INTRINSIC SAFETY CERTIFICATION

4.1 ATEX certificate

The IS-L101L beacon complies with the following standards:-

- EN60079-0:2006
- EN60079-11:2007
- EN60079-26:2007
- IEC60079-0:2007 (used for guidance in respect of marking)

 II 1G Ex ia IIC T4 Ga (-40°C ≤ Ta ≤ +60°C)

The EC-Type Examination Certificate SIRA 04ATEX2302X has been issued by the Notified Body Sira. This confirms compliance with the European ATEX Directive 94/9/EC for Group II, Category 1G equipment. The beacon carries the Community Mark and subject to local codes of practice, may be installed in any of the EEA member countries. This instruction sheet describes installations which conform to EN60079:Part14:2008 Electrical Installation in Hazardous

Areas. When designing systems for installation outside the UK, the local Code of Practice should be consulted.

1) The certification marking is as follows:

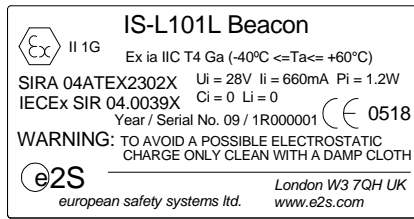

- 2) The equipment may be used in zones 0, 1 and 2 with flammable gases and vapours with apparatus groups IIA, IIB & IIC and with temperature classes T1, T2, T3 and T4.
- 3) The equipment is only certified for use in ambient temperatures in the range -40°C to +60°C and should not be used outside this range.
- 4) The certificate number has an 'X' suffix, which indicates that the certificate contains one of more special conditions for safe use. Those installing or inspecting the equipment should refer to this section of the certificate.
- 5) The equipment has not been assessed as a safety-related device (as referred to by Directive 94/9/EC Annex II, clause 1.5).
- 6) Installation of this equipment shall be carried out by suitably-trained personnel in accordance with the applicable code of practice.
- 7) Repair of this equipment shall only be carried out by the manufacturer or in accordance with the applicable code of practice.
- 8) The certification of this equipment relies on the following materials used in its construction:

Enclosure: ABS Plastic
 Lens: Polycarbonate

If the equipment is likely to come into contact with aggressive substances, then it is the responsibility of the user to take suitable precautions that prevent it from being adversely affected, thus ensuring that the type of protection is not compromised.

"Aggressive substances" - e.g. acidic liquids or gases that may attack metals, or solvents that may affect polymeric materials.

"Suitable precautions" - e.g. regular checks as part of routine inspections or establishing from the material's data sheet that it is resistant to specific chemicals.

SPECIAL CONDITIONS FOR SAFE USE (as stated on the IS-L101L EC Type Examination Certificate SIRA 04ATEX2302X)

The enclosure is non-conducting and may generate an ignition-capable level of electrostatic charges under certain extreme conditions. The user should ensure that the equipment is not installed in a location where it may be subjected to external conditions that might cause a build-up of electrostatic charges on non-conducting surfaces,

additionally, cleaning of the equipment should be done only with a damp cloth.

The equipment has an ingress protection rating of IP 66. However, if it has been supplied without cable entry devices, then the user shall ensure that the devices that are fitted will provide an ingress protection that is appropriate to the environment in which it is installed i.e. IP20 or better. If only one of the two cable entries are used, then the unused entry shall be fitted with a blanking device that ensures ingress protection appropriate to the environment in which it is installed i.e. IP20 or better.

SPECIAL CONDITIONS FOR SAFE USE (as stated on the IS-A105N sounder EC Type Examination Certificate SIRA 04ATEX2301X)

The equipment shall only be supplied via Terminals + w.r.t. Terminals - from a barrier having a maximum open circuit voltage U_o that is ≤ 28 V and a maximum short circuit current I_o that is ≤ 93 mA, where I_o is resistively limited. The barrier shall be ATEX certified by a notified body.

The total capacitance connected to terminals + wrt - (i.e. the capacitance of the cable plus any other capacitance) shall not exceed 83nF.

4.2 Zones, Gas Groups and T Rating

The IS-L101L beacon has been certified Ex ia IIC T4 Ga. When connected to an approved system it may be installed in:

- Zone 0 explosive gas air mixture continuously present.
- Zone 1 explosive gas air mixture likely to occur in normal operation.
- Zone 2 explosive gas air mixture not likely to occur, and if it does, it will only exist for a short time.

Be used with gases in groups:

- Group A propane
- Group B ethylene
- Group C hydrogen

Having a temperature classification of:

- T1 450°C
- T2 300°C
- T3 200°C
- T4 135°C

4.3 Terminals + and - power supply

Power is supplied to the beacon via terminals + and - which have maximum input safety parameters of:

$U_i = 28V$
 $I_i = 660mA$
 $P_i = 1.2W$
 $C_i = 0$ $L_i = 0$

IS-L101L beacons may be powered from ATEX certified Zener barriers or galvanic isolators certified by an EC Approved Body with output parameter equal to or less than 28V and 1.2W.

Up to three IS-L101L-IS beacons can be connected in parallel and be powered from a common barrier or isolator. Parallel connection of beacons will significantly reduce the

brightness of each device. Sounders must not be powered from beacons connected in parallel.

The equivalent capacitance and inductance between terminals + and - of the IS-L101L beacon and between terminals + and - of the IS-A105N sounder are zero. The maximum permitted cable parameters defined by the barrier or isolator certificate must not be exceeded.

4.4 Terminals S+ and S- connection for optional sounder

These terminals have the same maximum output safety parameters as the Zener barrier or isolator powering the beacon, i.e. they are equal to or less than:

$$\begin{aligned} U_o &= 28V \\ I_o &= 660mA \\ P_o &= 1.2W \\ C_i &= 0 \quad L_i = 0 \end{aligned}$$

However if an IS-A105N sounder was used in conjunction with the beacon a barrier with output parameters 28V 93mA and 660mW where I_o is resistively limited must be used (see sounder certificate) so then the S+ and S- terminal safety parameters are equal to or less than:

$$\begin{aligned} U_o &= 28V \\ I_o &= 93mA \\ P_o &= 660mW \\ C_i &= 0 \quad L_i = 0 \end{aligned}$$

If the beacon and sounder are mounted apart, for intrinsic safety assessment the capacitance and inductance of the interconnecting cable should be added to that of the cable connecting the barrier or isolator to the beacon. See section 4.3.

4.5 Terminals Ac.Sw - accept switch

The output safety parameters of these terminals are:

$$\begin{aligned} U_o &= 16.8V \\ I_o &= 3.61mA \\ P_o &= 15.2mW \end{aligned}$$

They may be connected to any mechanically operated switch in the same hazardous area as the beacon providing the switch has an IP protection suitable for the environmental conditions to which it is subjected and can withstand a 500V rms insulation test to earth for 1 minute.

5. INSTALLATION

In addition to the certification requirements shown in section 4.2 the environmental conditions must be within the limits shown on the product specification. The beacon enclosure provides IP66 protection and is suitable for installation in an exterior location if an appropriate sealed cable entry is used.

5.1 Mounting

The IS-L101L beacon may be secured to any flat surface using the two 6mm diameter fixing holes. The lens should be aimed towards the area where maximum visibility is required.

5.2 Installation procedure

- Remove the beacon lens by unscrewing the two captive screws and pull the lens away from the back box.
- Fit a suitable cable gland or conduit entry device that will maintain the enclosure ingress protection in the environmental conditions to which the unit is subjected, into one of the holes in the enclosure. Secure the back box to a vertical surface using the 6mm diameter holes in the two fixing lugs.

Alternatively, the IS-L101L beacon may be mounted directly onto a IS-A105N sounder enclosure and secured using a joining kit which is available from European Safety Systems Ltd.

- Finally connect the field wiring to the removable terminals, replace the lens and tighten the two captive screws.

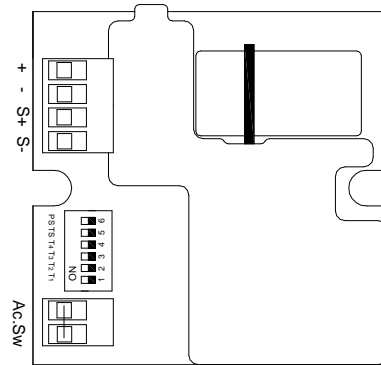

Fig 2 Location of field terminals and controls.

6. ELECTRICAL SYSTEM DESIGN FOR INSTALLATION IN HAZARDOUS AREAS USING ZENER BARRIERS

6.1 Stand alone operation

If the beacon is controlled by a switch in the positive supply, or the power supply is being turned on and off, only a single channel Zener barrier is required as shown in Fig 3. This circuit may also be used if the beacon is being controlled by a mechanically activated switch on the hazardous area side of the barrier. The power supply voltage should be between 20V and the maximum working voltage of the barrier. The circuit will continue to work at lower voltages, but the beacon brilliance will be reduced.

Note when the beacon is operated on its own, without a sounder connected, all of the DIP switches should be set to OFF position.

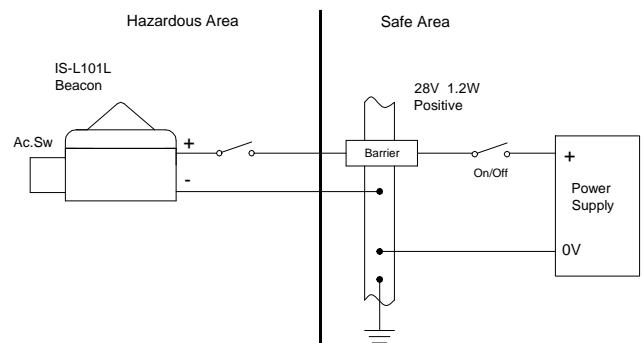

Fig 3 Using a single channel barrier.

If the beacon control switch is in the negative wire and the power supply 0V is earthed, the circuit shown in Fig 4 may be used. For simplicity the two barriers may be combined into one package. The power supply voltage should be between 21V and the maximum working voltage of the 28V barrier.

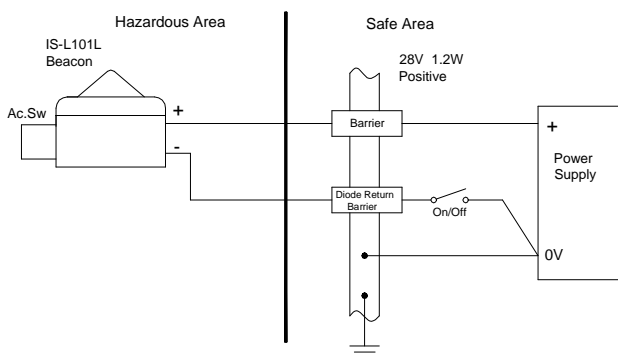

Fig 4 Single stage alarm using two channel barrier.

The circuit will continue to work at lower voltages, but the beacon brilliance will be reduced.

6.2 Use with a IS-A105N intrinsically safe sounder

When using the IS-L101L beacon with an IS-A105N sounder, the Special Conditions for Safe Use in the sounder certificate, Sira 04ATEX2301X must also be met.

The very low current consumption of the IS-L101L beacon allows it and a IS-A105N intrinsically safe sounder to be powered from a common Zener barrier as shown in Fig 5. This reduces the sounder output by about 2dB.

The IS-L101L beacon contains a circuit that will silence the sounder for a pre-set time, but leave the beacon flashing at twice its normal frequency. The sounder silence time is set by internal DIP switches. An operator may therefore silence the audible alarm but be continuously reminded of the alarm condition by the beacon. If the alarm is not cleared within the silence time, the sounder will be reactivated. If the alarm is cleared during the silence time the beacon will stop flashing, but the beacon and the sounder will both be re-activated if the alarm reoccurs. See table 1 on page 5 of these instructions for full DIP switch settings.

Note when the beacon is operated on its own, without a sounder connected, all of the DIP switches should be set to OFF the position.

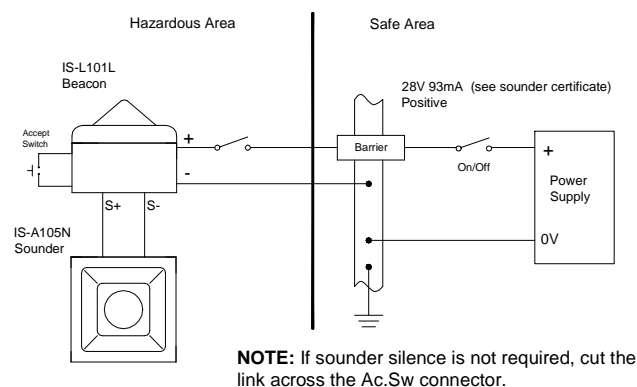

Fig 5 Combined beacon and sounder with alarm accept switch

The silence accept push-button may be any mechanically operated switch, providing it has an IP protection suitable for the environmental conditions to which it is subjected, located within the same hazardous area as the beacon, see section 4.5.

In order that the beacon continues to produce a reasonable light output level when used in conjunction with an IS-A105N

sounder, the power supply voltage to the barrier should be maintained at a minimum of 18V.

7. ELECTRICAL SYSTEM DESIGN FOR INSTALLATION IN HAZARDOUS AREAS USING GALVANIC ISOLATORS.

Although more expensive than Zener barriers, galvanic isolators are easier to install as they do not require a high integrity earth connection. Any certified device with output safety parameters below the maximum input safety parameters of the IS-L101L beacon may be used – See section 4.3.

7.1 Stand alone operation

Fig 6 shows the basic circuit that is used for all stand alone applications.

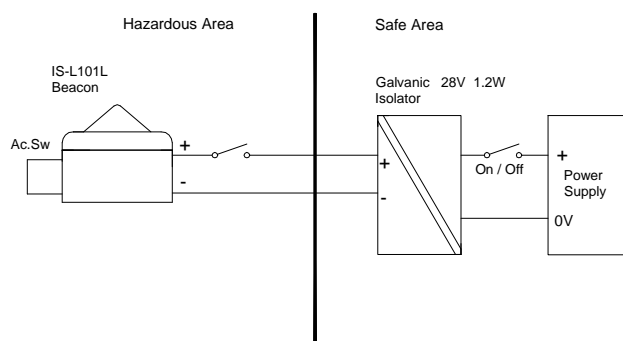

Fig 6 Basic circuit for use with a galvanic isolator.

The control arrangement will vary depending upon the isolator chosen. The galvanic isolator must be able to supply an output of 30mA at about 16V. This circuit may also be used if the beacon is controlled by a mechanically activated switch on the hazardous area side of the isolator.

7.2 Use with a IS-A105N intrinsically safe sounder

When using the IS-L101L beacon with a IS-A105N sounder, the Special Conditions for Safe Use in the sounder certificate, Sira 04ATEX2301X must also be met.

The very low current consumption of the IS-L101L beacon allows it and a IS-A105N intrinsically safe sounder to be powered from a common galvanic isolator as shown in Fig 7. This reduces the sounder output by about 2dBA.

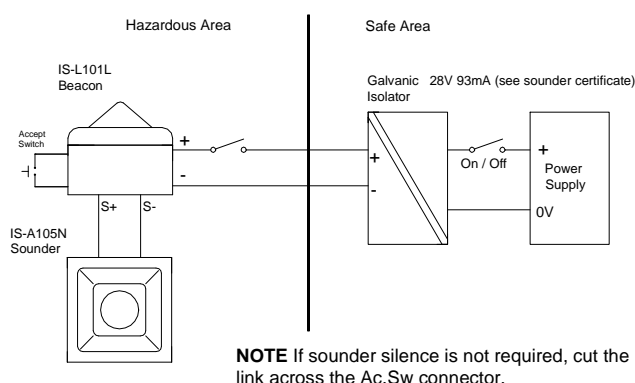

Fig 7 Combined beacon and sounder with alarm accept switch

The IS-L101L beacon contains a circuit that will silence the sounder for a pre-set time, but leave the beacon flashing at twice its normal frequency. The sounder silence time is set by internal DIP switches. An operator may therefore silence the

audible alarm but be continuously reminded of the alarm condition by the beacon. If the alarm is not cleared within the silence time, the sounder will be reactivated. If the alarm is cleared during the silence time the beacon will stop flashing, but the beacon and the sounder will both be re-activated if the alarm reoccurs. See table 1 on page 5 of these instructions for full DIP switch settings.

The silence accept push-button may be any mechanically operated switch, providing it has an IP protection suitable for the environmental conditions to which it is subjected, within the hazardous area, see section 4.5.

9. ACCESSORIES

9.1 Beacon to sounder joining kit

Comprises an M20 plastic conduit coupler and gasket enabling the beacon to be mounted onto a IS-A105N sounder. This kit is supplied free of charge when a beacon and sounder are purchased at the same time.

10. MAINTENANCE

The beacon should be regularly inspected to ensure that it has not been damaged. Frequency of inspection depends upon environmental conditions, but initially we recommend that this should be done annually.

No attempt should be made to repair a faulty IS-L101L beacon. Suspect beacons must be returned to European Safety Systems Ltd. or to your local agent for repair.

11. GUARANTEE

Beacons which fail within the guarantee period should be returned to European Safety Systems Ltd. or our local agent. It is helpful if a brief description of the fault symptoms is provided.

12. CUSTOMER COMMENTS

European Safety Systems Ltd. are always pleased to receive comments from customers about our products and services. All communications are acknowledged and whenever possible, suggestions are implemented.

Switch settings for operation with IS-A105N Sounder

Note when the beacon is operated on its own, without a sounder connected, all of the DIP switches should be set to OFF position.

SW6 PS	SW5 OS	SW4 T4	SW3 T3	SW2 T2	SW1 T1	Timer	Periodic sound interval when silenced, when SW6 is ON for (1 second every)
		OFF	OFF	OFF	OFF	forever	10 secs
		OFF	OFF	OFF	ON	5 secs	5 secs
		OFF	OFF	ON	OFF	10 secs	5 secs
		OFF	OFF	ON	ON	20 secs	5 secs
		OFF	ON	OFF	OFF	30 secs	5 secs
		OFF	ON	OFF	ON	45 secs	10 secs
		OFF	ON	ON	OFF	1 min	10 secs
		OFF	ON	ON	ON	2 mins	10 secs
		ON	OFF	OFF	OFF	3 mins	30 secs
		ON	OFF	OFF	ON	5 mins	30 secs
		ON	OFF	ON	OFF	10 mins	1 min
		ON	OFF	ON	ON	20 mins	1 min
		ON	ON	OFF	OFF	30 mins	1 min
		ON	ON	OFF	ON	45 mins	5 mins
		ON	ON	ON	OFF	1 hour	5 mins
		ON	ON	ON	ON	2 hours	5 mins
	OFF					Hold off mode – Accept Switch silences sounder for selected time.	
	ON					One-shot mode — Sounder silences after either selected time, or Accept Switch is pressed, whichever occurs first. The sounder is then only restored after the input power supply is removed and restored.	
OFF						No periodic sound while silenced	
ON						Sound periodically while silenced	

IECEX Certification

The IS-L101L Beacon has also been approved to the IECEx scheme.

The installation requirements for IS-L101L beacons approved to the IECEx scheme are the same as the installation requirements for IS-L101L beacons approved to the ATEX directive.

Certificate No. IECEx SIR 04.0039X

Marking: Ex ia IIC T4 Ga (Ta = -40°C to +60°C)

Standards: IEC 60079-0:2004 Edition 4
IEC 60079-11:2006 Edition 5
IEC 60079-26:2006 Edition 2

CONDITIONS OF CERTIFICATION (as stated on the IS-L101L Beacon IECEx Certificate of Conformity IECEx SIR 04.0039X)

- The equipment has an ingress protection rating of IP66; however, if it has been supplied without a cable entry device, then the user shall ensure that the device that is fitted will provide an ingress protection that is appropriate to the environment in which it is installed i.e. IP20 or better. If only one of the two cable entries are used, then the unused entry shall be fitted with a blanking device that ensures ingress protection appropriate to the environment in which it is installed i.e. IP20 or better.
- The enclosure is non-conducting and may generate an ignition-capable level of electrostatic charges under certain extreme conditions. The user should ensure that the equipment is not installed in a location where it may be subjected to external conditions that might cause a build-up of electrostatic charges on non-conducting surfaces, additionally, cleaning of the equipment should be done only with a damp cloth.

The IS-L101L beacons are marked with the certification requirements for the ATEX and IECEx approvals.

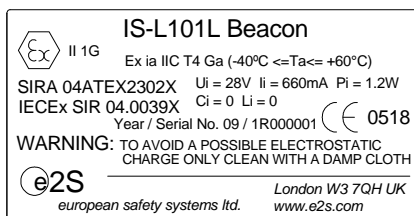

If the IS-L101L beacon is used in conjunction with an IS-A105N sounder then the following certification conditions apply:-

CONDITIONS OF CERTIFICATION (as stated on the IS-A105N Sounder IECEx Certificate of Conformity IECEx SIR 04.0038X)

- The equipment shall only be supplied via Terminals + w.r.t. Terminals - from a certified barrier having a maximum open circuit voltage U_o that is less than or equal to 28 V and a maximum short circuit current I_o that is less than or equal to 93 mA, where I_o is resistively limited.
- The total capacitance connected to terminals + wrt - (i.e. the capacitance of the cable plus any other capacitance) shall not exceed 83nF.

FM Approval

The IS-L101L Beacon has also been FM Listed.

Marking: IS Class I, Zone 0, AEx ia IIC T4

IS Class I, Division 1, Groups A, B, C, D

See the Control Drawings D 4627 Sheets 1 to 4 for installation details and entity parameters.

The IS-L101L beacons are marked with the certification requirements for the FM approval.

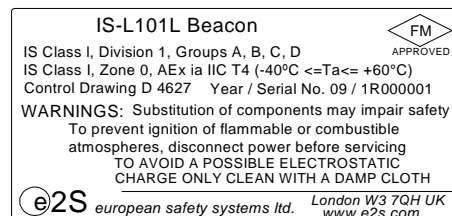

Hazardous (Classified) Location
 Class I, Division 1, Groups A, B, C, D
 Class I, Zone 0, Groups IIA, IIB, IIC

Unclassified Location

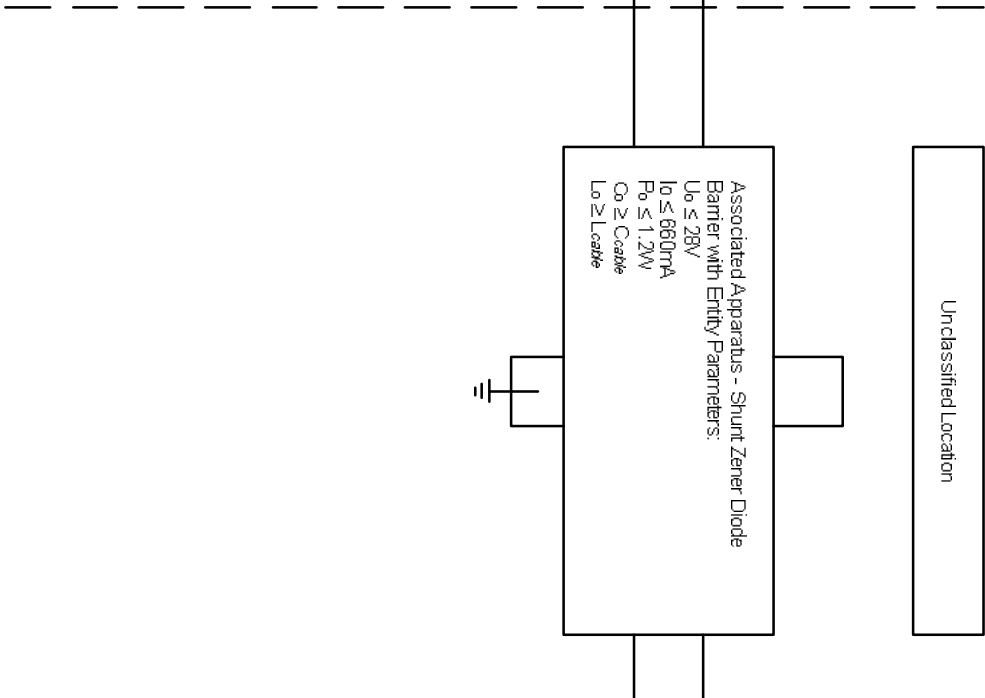
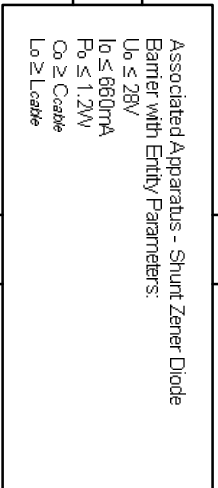
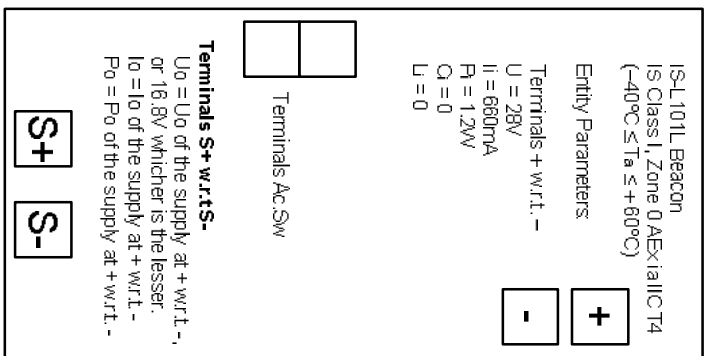

1. No revision to drawing without prior FM approval.
2. The associated apparatus must be FM approved.
3. The associated apparatus manufacturer's installation drawing must be followed when installing this equipment.
4. Installation should be in accordance with ANSISA RP12.06.01 "Installation of Intrinsically Safe Systems for Hazardous (Classified) Locations" and the National Electrical Code (ANSINFPFA 70).
5. The resistance between the intrinsically safe ground and the earth ground must be less than 1 ohm.

6. The Shunt Zener Diode Barrier must be a FM approved, resistively limited, single channel barrier having parameters less than, or equal to, those quoted, and for which the output is non-ignition capable for the Class, Division or Zone and Group of use.

7. The IS-L101L Beacon enclosure has an ingress protection rating of IP 66. If supplied without cable entry devices then metallic or plastic cable glands, or conduit hubs, shall be fitted that provide the required environmental protection.

8. To prevent ignition of flammable or combustible atmospheres, disconnect power before servicing.

9. Substitution of components may impair safety.

Note:
 CAUTION - Bonding between conduit connections is not automatic and must be provided as part of this installation.

Issue:	A	Appd.	MRS	Date:	17-02-06	Drawn:	GU	Date:	20-10-05

Title
 IS-L101L Beacon
 Control Drawing for shunt Zener
 diode barrier.

2S
 warning signals

European Safety Systems Ltd.
 Inpress House
 Mansell Road
 Acton
 London W9 7QH
 Computer Ref: J 4627a.dwg

Drawing No.
D 4627 Sheet 1 of 4

Hazardous (Classified) Location
 Class I, Division 1, Groups A, B, C, D
 Class I, Zone 0, Groups IIA, IIB, IIC

Unclassified Location

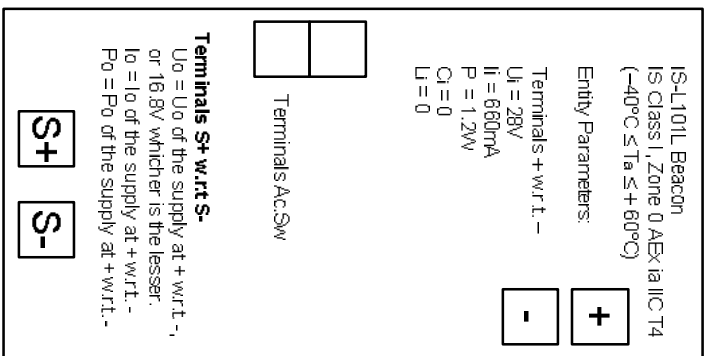

1. No revision to drawing without prior FM approval.
2. The associated apparatus must be FM approved.
3. The associated apparatus manufacturer's installation drawing must be followed when installing this equipment.
4. Installation should be in accordance with ANS/ISA RP12.06.01 "Installation of Intrinsically Safe Systems for Hazardous (Classified) Locations" and the National Electrical Code (ANSI/NFPA 70).
5. The Galvanically Isolated Supply must be a FM approved, resistively limited, single channel supply having parameters less than, or equal to, those quoted, and for which the output is non-ignition capable for the Class, Division or Zone and Group of use.
6. The IS-L101L Beacon enclosure has an ingress protection rating of IP 66. If supplied without cable entry devices then metallic or plastic cable glands, or conduit hubs, shall be fitted that provide the required environmental protection.
7. To prevent ignition of flammable or combustible atmospheres, disconnect power before servicing.
8. Substitution of components may impair safety.

Note:
 CAUTION - Bonding between conduit connections is not automatic and must be provided as part of this installation.

Issue:	A	Appd.	MRS	Date:	17-02-06	Drawn:	GU	Date:	20-10-05

Title
 IS-L101L Beacon
 Control Drawing for galvanically
 isolated supply.

2S
 warning signals

European Safety Systems Ltd.
 Inpress House
 Mansell Road
 Acton
 London W9 7QH

Computer Ref: 34627b.dwg

Drawing No.
D 4627 Sheet 2 of 4

Hazardous (Classified) Location
Class I, Division 1, Groups A, B, C, D
Class I, Zone 0, Groups IIA, IIB, IIC

Unclassified Location

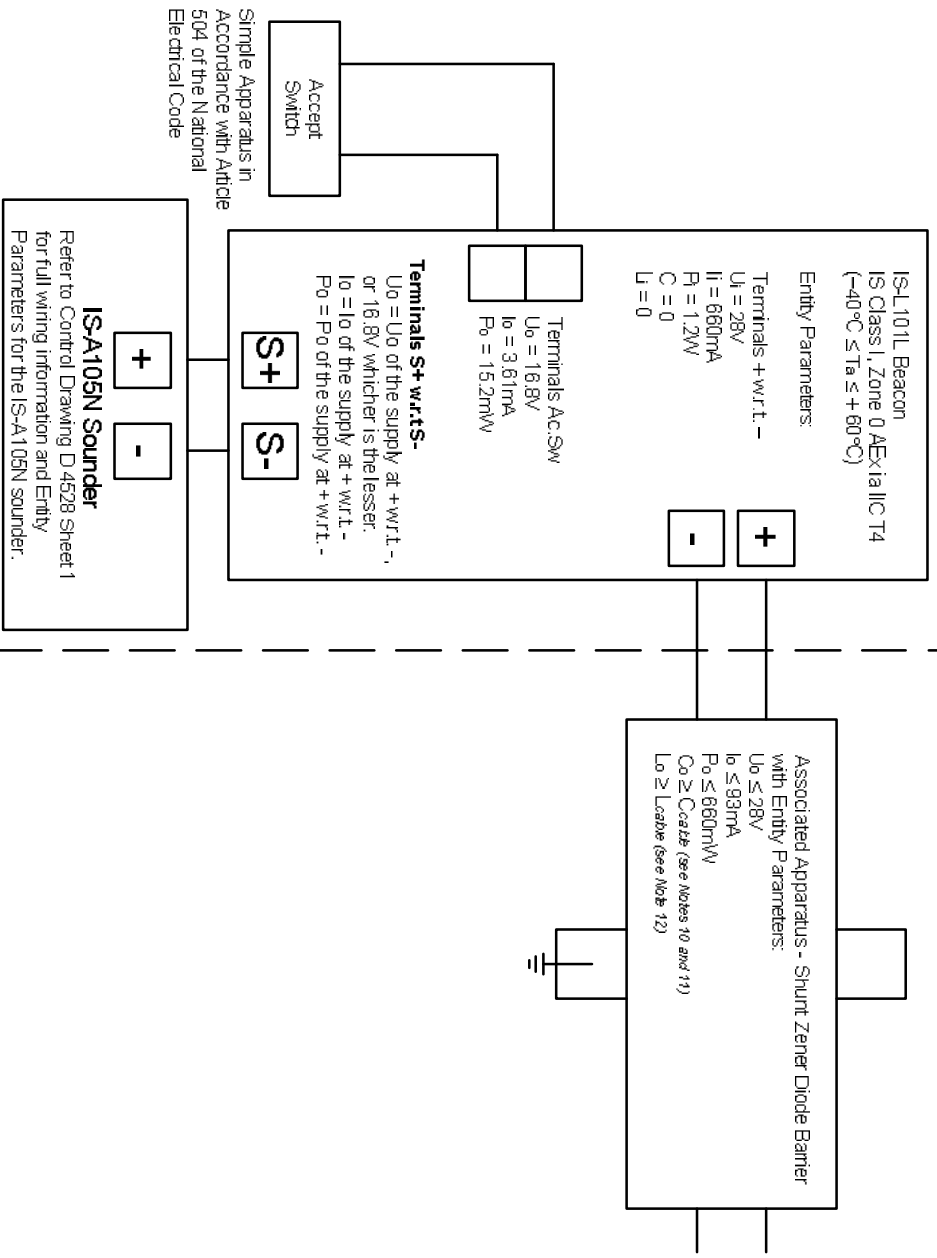

1. No revision to drawing with out prior FM approval.
 2. The associated apparatus must be FM approved.
 3. The associated apparatus manufacturer's installation drawing must be followed when installing this equipment.
 4. Installation should be in accordance with ANSISA RP12.06.01 "Installation of Intrinsically Safe Systems for Hazardous (Classified) Locations" and the National Electrical Code (ANSI/NFPA 70).
 5. The resistance between the intrinsically safe ground and the earth ground must be less the 1 ohm.
 6. The Shunt Zener Diode Barrier must be a FM approved, resistively limited, single channel barrier having parameters less than, or equal to, those quoted, and for which the output is non-ignition capable for the Class, Division or Zone and Group of use.
 7. The IS-L101L Beacon enclosure has an ingress protection rating of IP 66. If supplied without cable entry devices then metallic or plastic cable glands, or conduit hubs, shall be fitted that provide the required environmental protection.
 8. To prevent ignition of flammable or combustible atmospheres, disconnect power before servicing.
 9. Substitution of components may impair safety.
 10. Cable = capacitance of cable connecting the shunt zener diode barrier to the beacon + capacitance of the cable connecting the sounder to the beacon.
 11. The total capacitance connected to terminals +- of the beacon plus the total capacitance connected to terminals +- of the sounder, i.e. Cable plus any other capacitance, shall not exceed 83nF.
 12. L₀ cable = loop inductance of cable connecting the shunt zener diode barrier to the beacon + loop inductance of cable connecting the sounder to the beacon.
- Note:**
CAUTION - Bonding between conduit connections is not automatic and must be provided as part of this installation.

		Title	
		IS-L101L Beacon (used with IS-A105N sounder) Control Drawing for shunt zener diode barrier.	
		Drawing No.	
		D 4627 Sheet 3 of 4	
		European Safety Systems Ltd. Impress House Marshall Road Aldon London W8 7QH Computer Ref. J 4627.dwg	
Issue: A		Appd. MRS	Date: 17-02-06
		Drawn: GU	Date: 20-10-05

Hazardous (Classified) Location
Class I, Division 1, Groups A, B, C, D
Class I, Zone 0, Groups IIA, IIB, IIC

Unclassified Location

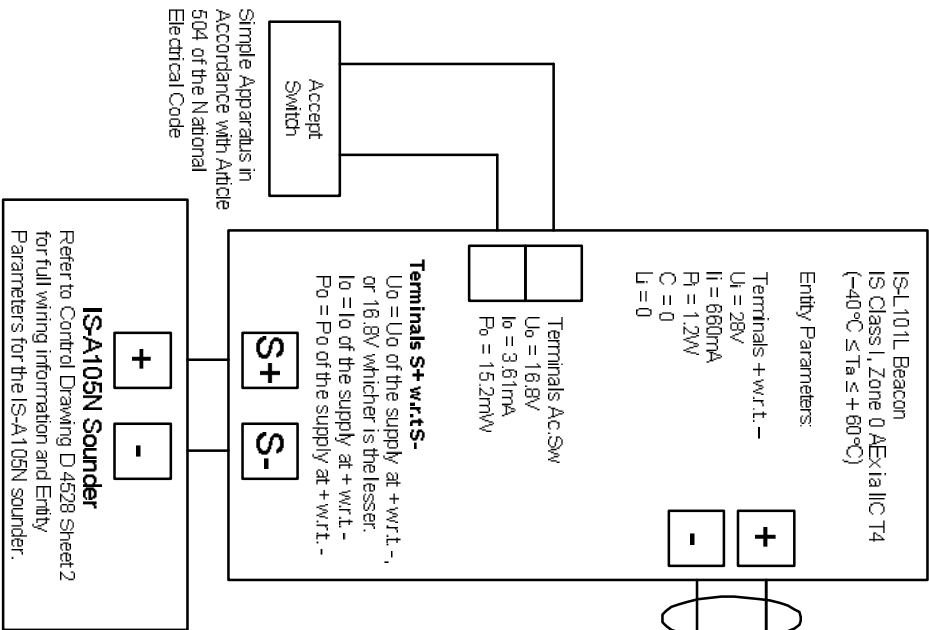

Associated Apparatus - Galvanically Isolated Supply with Entity Parameters:
 $U_o \leq 28V$
 $I_o \leq 93mA$
 $P_o \leq 680mW$
 $C_o \geq \text{Cable (see Notes 9 and 10)}$
 $L_o \geq \text{Lead (see Note 11)}$

ISA105N Sounder
 Refer to Control Drawing D 4628 Sheet 2 for full wiring information and Entity Parameters for the IS-A105N sounder.

Simple Apparatus in Accordance with Article 504 of the National Electrical Code

Issue:	A	MRS	17-02-06	Drawn:	GU	Date:	20-10-05
Appd.							

Title
 IS-L101L Beacon (used with IS-A105N sounder)
 Control Drawing for galvanically isolated supply.

2S European Safety Systems Ltd.
 Inpress House
 Mansell Road
 Acton
 London W9 7QH

Computer Ref: D 4627.dwg
Drawing No. D 4627 Sheet 4 of 4

1. No revision to drawing without prior FM approval.
 2. The associated apparatus must be FM approved.
 3. The associated apparatus manufacturer's installation drawing must be followed when installing this equipment.
 4. Installation should be in accordance with ANSISA RP12.06.01 "Installation of Intrinsically Safe Systems for Hazardous (Classified) Locations" and the National Electrical Code (ANSI/NFPA 70).
 5. The Galvanically Isolated Supply must be a FM approved, resistively limited, single channel supply having parameters less than, or equal to, those quoted, and for which the output is non-ignition capable for the Class, Division or Zone and Group of use.
 6. The IS-L101L Beacon enclosure has an ingress protection rating of IP 66. If supplied without cable entry devices then metallic or plastic cable glands, or conduit hubs, shall be fitted that provide the required environmental protection.
 7. To prevent ignition of flammable or combustible atmospheres, disconnect power before servicing.
 8. Substitution of components may impair safety.
 9. *Cable* = capacitance of cable connecting the galvanically isolated supply to the beacon + capacitance of the cable connecting the sounder to the beacon.
 10. The total capacitance connected to terminals +/- of the beacon plus the total capacitance connected to terminals +/- of the sounder, i.e. *Cable* plus any other capacitance, shall not exceed 83nF.
 11. *Lease* = loop inductance of cable connecting the galvanically isolated supply to the beacon + loop inductance of cable connecting the sounder to the beacon.
- Note:**
 CAUTION - Bonding between conduit connections is not automatic and must be provided as part of this installation.

EC DECLARATION OF CONFORMITY



Manufacturer: European Safety Systems Ltd.
Impress House, Mansell Road, Acton
London, W3 7QH, UK

Equipment Type: IS-L101L

Directive 94/9/EC: Electrical and Mechanical equipment for use in explosive atmospheres (ATEX)

Notified Body for EC type Examination: Sira Certification Service
Notified Body No.: 0518
Rake Lane, Eccleston, Chester CH4 9JN, UK

EC-type Examination Certificate: SIRA 04ATEX2302X

Notified Body for Quality Assurance Notification: Sira Certification Service
Notified Body No.: 0518
Rake Lane, Eccleston, Chester CH4 9JN, UK

Quality Assurance Notification: SIRA 05 ATEX M342

Provisions fulfilled by the equipment: II 1G Ex ia IIC T4 Ga (-40 °C ≤ Ta ≤ +60 °C)

Standards applied: EN 60079-0:2006
IEC 60079-0:2007
EN 60079-11 :2007
EN 60079-26:2007

Directive 2004/108/EC: Electromagnetic Compatibility Directive (EMC)

Standards applied: EN 61000-6-1:2007
EN 61000-6-2:2005
EN 61000-6-3:2007
EN 61000-6-4:2007

The standards EN 60079-0: 2006 and EN 60079-11:2007 are no longer harmonized. The requirements of these standards have been checked against the harmonized standards EN 60079-0:2009 and EN 60079-11:2012 and there were no major technical changes affecting the latest technical knowledge for the products listed above.

On behalf of European Safety Systems Ltd., I declare that, on the date the equipment accompanied by this declaration is placed on the market, the equipment conforms with all technical and regulatory requirements of the above listed directives.

A handwritten signature in black ink, appearing to read 'Martin Streetz'.

Martin Streetz
Quality Assurance Manager

Date and Place of Issue: London, 04/07/2012
Document No: DC-010-Issue_C